

R

Accession Number: (434) 91-0289

File Code Number: 19 14-26

402619

Division/Department/Group: Life Sciences

Series Title: Scientific Files of Cornelia Tobias

Box Number: 1/6

Folder Title: Environmental Contamination from Weapon Tests

HASL-42

cy 4

Environmental CONTAMINATION

from

WEAPON TESTS

RECEIVED
RADIATION LABORATORY

FEB 24 1959

TECHNICAL
INFORMATION DIVISION
BERKELEY

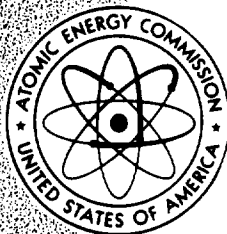

UNITED STATES
ATOMIC ENERGY COMMISSION

LEGAL NOTICE

This report was prepared as an account of Government sponsored work. Neither the United States, nor the Commission, nor any person acting on behalf of the Commission:

A. Makes any warranty or representation, express or implied, with respect to the accuracy, completeness, or usefulness of the information contained in this report, or that the use of any information, apparatus, method, or process disclosed in this report may not infringe privately owned rights; or

B. Assumes any liabilities with respect to the use of, or for damages resulting from the use of any information, apparatus, method, or process disclosed in this report.

As used in the above, "person acting on behalf of the Commission" includes any employee or contractor of the Commission to the extent that such employee or contractor prepares, handles or distributes, or provides access to, any information pursuant to his employment or contract with the Commission.

Price \$3.50. Available from the Office of Technical Services, Department of Commerce, Washington 25, D. C.

Printed in USA.

Prepared by Technical Information Service Extension, AEC
Oak Ridge, Tennessee

Radiation Laboratory

Berkeley

Assigned to

C. Tobias

Route to	Noted

Please return this document to the Information Division. Do not send it to the next person on the list.

Please do not remove this page.

Environmental
CONTAMINATION

from

WEAPON TESTS

Issuance Date: October 1958

HEALTH AND SAFETY LABORATORY
UNITED STATES ATOMIC ENERGY COMMISSION
New York Operations Office

ABSTRACT

Parts 1 and 2 of this report present data pertinent to the monitoring of long-range fallout, particularly Sr^{90} and Cs^{137} . Values are tabulated for the fallout deposition, air concentrations, water concentrations, and the amounts in foods and human bone. In addition, results are given for some experimental investigations. The report of these results is not interpretative although certain papers that do attempt to interpret the present situation with respect to Sr^{90} in particular are reprinted in Part 4.

Part 3 presents bibliographies covering the period since the 1957 hearings before the Joint Committee on Atomic Energy concerning the nature of radioactive fallout and its effects on man. A document list of submissions to the United Nations Scientific Committee on the Effects of Atomic Radiation is given to illustrate the work done in other countries, and, finally, several papers on the subject, which have not been generally available, are reprinted in Part 4.

ACKNOWLEDGMENTS

This report has been prepared by the staff of the Health and Safety Laboratory, AEC. Edward P. Hardy, Jr., and John H. Harley have been responsible for the editing of the material, under the direction of Dr. S. Allan Lough, Director of the Laboratory.

The compilers of this summary appreciate the assistance given by workers in this field in making their data available. In particular, the following groups have allowed reproduction of their results: Dr. W. F. Libby and Dr. E. A. Martell, The University of Chicago; Dr. J. Laurence Kulp, Lamont Geological Observatory; Dr. N. G. Stewart, Dr. F. J. Bryant, and Dr. J. Rundo, Atomic Energy Research Establishment (Harwell); Dr. W. E. Grummitt, Atomic Energy of Canada Limited; Dr. Wright Langham and Dr. E. C. Anderson, Los Alamos Scientific Laboratory; Dr. J. Terrill and Dr. Lloyd Setter, U. S. Public Health Service; Dr. Luther B. Lockart, Naval Research Laboratory; and Dr. Leo Marinelli and Dr. C. E. Miller, Argonne National Laboratory.

The editors wish to acknowledge the assistance of Hal Hollister, Division of Biology and Medicine, AEC, in the preparation of the bibliographies and in obtaining reports for inclusion in this report.

This report has been prepared and given limited distribution in four volumes designated as HASL-42, Parts A, B, C, and D.

CONTENTS

ABSTRACT	iii
ACKNOWLEDGMENTS	v
INTRODUCTION	1
Part 1—FALLOUT MONITORING AND DOCUMENTATION	
1 DEPOSITION	5
1.1 Pot Fallout Collections	6
1.2 Precipitation Collections for Radiostrontium and Radiobarium	6
1.3 Sr ⁹⁰ in Soil	6
1.4 Summary of Gunned Film Fallout Measurements Through June 1957	8
2 AIR	36
2.1 Surface Air	36
2.2 High-altitude Samples	38
3 WATER	48
3.1 Tap Water	48
3.2 River, Precipitation, and Reservoir Water	48
3.3 Sea Water	48
4 UPTAKE OF Sr ⁹⁰ AND Cs ¹³⁷	57
4.1 Milk	57
4.2 Other Food and Herbage	60
4.3 Sr ⁹⁰ in Urine	61
4.4 Bone	61
4.5 Whole-body Measurements of Cs ¹³⁷	62
Part 2—EXPERIMENTAL INVESTIGATIONS	
5 UPTAKE STUDIES	125
5.1 HASL Pasture Site Surveys	125
5.2 Chicago Milkshed Area Survey	125
5.3 Uptake of Sr ⁹⁰ by Bean Plants	125

CONTENTS (Continued)

5.4	Turnip Experiment	126
5.5	Distribution of Sr ⁹⁰ in Animal Bone	126
5.6	Sr ⁹⁰ in Human Milk	126
6	FALLOUT MECHANISM	136
6.1	Precipitation Samples Collected at Mount Washington Observatory	136
6.2	New Haven Dustfall	136
6.3	Fallout Collections in Hartford, Conn., Area	136
6.4	Sr ⁹⁰ in Antarctic Snow	137
6.5	Sr ⁹⁰ in U. S. Weather Bureau Polar Operations Snow Samples	137
6.6	Sr ⁹⁰ in Nevada Soil Samples	137
6.7	Sr ⁹⁰ in Hawaiian Air Samples	137
6.8	Sr ⁹⁰ Fallout Collections on Weather Ships	138
7	VARIABILITY OF Sr ⁹⁰ IN MILK	150
7.1	New York State Department of Health Milk Powdering Plant Survey	150
7.2	Variability of Sr ⁹⁰ in Powdered Milk During a One-day Spray-drying Operation at Columbus, Wisc.	150
7.3	Variability of Sr ⁹⁰ in Milk Collected at Six Wisconsin Farms	150

Part 3—BIBLIOGRAPHIES

Annotated Bibliography on Long-range Effects of Fallout from Nuclear Explosions	157
Bibliography—Miscellaneous Papers Published Since the Congressional Hearings of 1957	169
Bibliography of Documents Submitted to the United Nations Scientific Committee on the Effects of Atomic Radiation	173

Part 4—SELECTED PAPERS

Radiostrontium in Soil, Grass, Milk, and Bone in the United Kingdom, 1956 Results	209
The World-wide Deposition of Long-lived Fission Products from Nuclear Test Explosions	231
Measurements of Cs ¹³⁷ in Human Beings in the United Kingdom	249
Remarks Prepared by Dr. Willard F. Libby	253
Statement on Radioactive Fallout	269

CONTENTS (Continued)

Biological Factors in the Radiation Problem Relating to Society	277
Entry of Radioactive Fallout into the Biosphere and Man	282
Discussion of Meteorological Factors and Fallout Distribution	310
Meteorological Interpretation of Sr ⁹⁰ Fallout	327
A Study of Fallout in Rainfall Collections from March Through July 1956	339
A New Method for Collection of Fallout Material from Nuclear Detonations	355

LIST OF ILLUSTRATIONS*

1 Sr ⁹⁰ in New York City Fallout (High-walled Stainless-steel Pot Collections)	7
2 Sr ⁹⁰ in Pittsburgh Fallout (Galvanized Tub Collections)	7
3 Location of Lamont Geological Observatory Soil Sampling Sites, 1955	9
4 Histogram of Sr ⁹⁰ Per Square Foot for New York Soils	9
5 Cumulative Sr ⁹⁰ Deposition in United States as of June 1957, Gunned Film Measurements	10
6 Cumulative World-wide Sr ⁹⁰ Deposition as of June 1957, Gunned Film Measurements	12
7a Variation of Sr ⁹⁰ and Cs ¹³⁷ Activity with Altitude	37
7b Variation of Sr ⁹⁰ Activity with Latitude	37
8 Sr ⁹⁰ in New York City Tap Water	48
9 Monthly Sr ⁹⁰ Levels in New York City Liquid Milk	58
10 Monthly Sr ⁹⁰ Levels in Perry, N. Y., Powdered Milk	58
11 Monthly Sr ⁹⁰ Levels in Mandan, N. Dak., Powdered Milk	59
12 Monthly Sr ⁹⁰ Levels in Columbus, Wisc., Powdered Milk	59
13 Histogram of Sr ⁹⁰ Concentration in Bones	62
14 Pot Fallout Collections in the Hartford Area	137
15 New York State Department of Health Milk Powdering Plant Survey	151

LIST OF TABLES*

1 Pot Fallout Collections, New York City	13
2 Monthly Pot Fallout Collections at Other United States Locations	17
3 Monthly Pot Fallout Collections at Locations Outside the United States	19
4 Rainfall Sample Analyses, Pittsburgh, Pa.	23
5 Rainfall Sample Analyses, Chicago, Ill.	28

*For Parts 1 and 2.

LIST OF TABLES (Continued)

6	Millicuries of Sr ⁹⁰ Per Square Mile in U. S. Soil Samples Collected During October 1955, 1956, and 1957	29
7	Geographical Distribution of Sr ⁹⁰ in Soil, 1955	30
8	Depth Distribution of Sr ⁹⁰ in Soil	30
9	Sr ⁹⁰ in Soil Collected Outside the United States	31
10	Cumulative Sr ⁹⁰ Deposition (Millicuries Per Square Mile) Estimated from Gummied Film Measurements for Continental United States	34
11	Cumulative Sr ⁹⁰ Deposition (Millicuries Per Square Mile) Estimated from Gummied Film Measurements Outside Continental United States	35
12a	Sr ⁹⁰ Surface Air Concentration, Washington, D. C.	39
12b	Sr ⁹⁰ Surface Air Concentration, Foreign Locations	40
13	United States Public Health Service Stations Measuring Total Fission Product Activity in Air Samples	42
14	Stratospheric Data, 1957	42
15	High-altitude Sampling Data	43
16	Sr ⁹⁰ in New York City Tap Water	50
17a	Sr ⁹⁰ in Tap Water Collected by the University of Chicago	50
17b	Sr ⁹⁰ in Tap Water Collected by the Lamont Geological Observatory	50
18	Mississippi River Water	51
19a	Sr ⁹⁰ in River Water Samples Collected by the University of Chicago	52
19b	Sr ⁹⁰ in Reservoir and Precipitation Water Samples Collected by the Lamont Geological Observatory	52
20a	Sr ⁹⁰ in Sea Water Collected by the University of Chicago	53
20b	Sr ⁹⁰ in Sea Water Collected by the Lamont Geological Observatory	53
21	Radioisotopes in Surface Water	54
22	Sea Water Samples	55
23	Monthly Radiostrontium Levels in Liquid Milk from New York City	64
24	Monthly Radiostrontium Levels in Powdered Milk from Perry, New York	64
25	Monthly Sr ⁹⁰ Levels in Powdered Milk from Other United States Locations	65
26	Sr ⁹⁰ in Milk Collected Outside the United States	66
27	Public Health Service — Milk Samples	67
27a	Radioactivity in Milk	67
28	Milk Analyzed at the University of Chicago	68
29	Milk Samples Reported by the Lamont Geological Observatory	70
30a	Sr ⁹⁰ in Skim Milk Power	71
30b	Sr ⁸⁹ in Skim Milk Powder	71
31a	Cs ¹³⁷ Determinations in Milk, 1956	72
31b	Cs ¹³⁷ Determinations in Milk, 1957-1958	74
31c	Cs ¹³⁷ Determinations in Milk	86
32	Sr ⁹⁰ in Canned Fish	87

LIST OF TABLES (Continued)

33	Sr ⁹⁰ in United States Food	88
34	Sr ⁹⁰ in Common United States Food, 1956-1957	88
35	Cheese Samples Analyzed at the University of Chicago	90
36	Cheese Samples Analyzed at the Lamont Geological Observatory	91
37	Cheese Samples Analyzed for Sr ⁹⁰ at HASL	91
38	Diet Sampling Surveys Conducted Outside the United States	92
39	Miscellaneous Vegetation, 1956 to 1957	95
40	Sr ⁹⁰ in Human Urine	95
41	Miscellaneous Animal Bone, HASL	96
42	Animal Bone Analyzed at the University of Chicago	96
43	Animal Bone Samples Analyzed at Lamont Geological Observatory	98
44	Average Sr ⁹⁰ Content in Man	98
45	Sr ⁹⁰ in Infant Bone Analyzed at the University of Chicago	99
46	Sr ⁹⁰ in Miscellaneous Infant Bone Analyzed at the University of Chicago	99
47	Sr ⁹⁰ in Human Teeth	100
48a	Whole-body Cs ¹³⁷ Controls, 1956	101
48b	Whole-body Cs ¹³⁷ Determinations, 1956	105
48c	Whole-body Cs ¹³⁷ Controls, 1957	113
48d	Whole-body Cs ¹³⁷ Determinations, 1957	116
48e	Whole-body Cs ¹³⁷ Measurements, 1957	120
49a	Chicago Subjects (42°N) During June 1957	121
49b	Data on Foreign Subjects	122
50	HASL Pasture Program	127
51	HASL Pasture Program	128
52	HASL Pasture Program	129
53	Chicago Pasture Site Survey	130
54	Chicago Pasture Site Survey	131
55	Chicago Pasture Site Survey	131
56	Study of Uptake of Bean and Black-eyed Pea Plants	132
57	Turnip Experiment	133
58	Distribution Study of Sr ⁹⁰ in Animal Bone	133
59	Samples of Sr ⁹⁰ in Milk	134
60	Precipitation Collections at Mt. Washington Observatory	139
61	New Haven Dustfall Experiment	140
62	Fallout Collections in the Hartford, Conn., Area	142
63	Antarctic Snow	143
64	Snow Samples	144
65	Sr ⁹⁰ in Nevada Soil Samples	145
66	Air Filters — Hawaii	147
67	Fallout Analysis of Rain Gauge Collections	149
68	Milk Powdering Plant Survey for Sr ⁹⁰ in Powdered Milk	152
69	Variability of Sr ⁹⁰ in Powdered Milk During a One-day Spray-drying Operation	153
70	Variability of Sr ⁹⁰ in Milk Collected at Six Wisconsin Farms on the Same Day, August 1957	153

INTRODUCTION

The program of the Atomic Energy Commission on environmental contamination from weapons tests is designed for the over-all evaluation of the hazard to humans from test operations. It is limited to studies of the deposition of activity at long range rather than the problems associated with immediate, close-in fallout. The program has largely been a study of Sr^{90} , since considerations based on experience and measurement indicate that it is the isotope of greatest potential hazard.

The data on fallout were last summarized in the report, *The Nature of Radioactive Fallout and Its Effects on Man* (Hearings before the Special Subcommittee on Radiation of the Joint Committee on Atomic Energy, Congress of the United States, May 27–June 7, 1957). The next important summary will be in the report to the United Nations General Assembly from its Special Scientific Committee on the Effects of Atomic Radiation, which should appear during the current year.

The present report has been prepared by the Health and Safety Laboratory, under the direction of the Division of Biology and Medicine of the AEC to summarize, in tabular form, the data available on the monitoring of Sr^{90} and Cs^{137} levels in man and his environment. Many of the studies reported are documentary in nature, i.e., they are designed to produce a permanent record of the concentration of Sr^{90} existing in various materials at the time. Naturally, other ideas in addition to specific monitoring programs are pursued where they may be fruitful as an aid in understanding the processes involved. However, the material presented here is largely the result of surveys rather than planned experimentation.

The data reported is not an evaluation of the hazard from weapons testing. The final interpretation of data is a medical and biological problem, requiring studies of the uptake of Sr^{90} by man from his environment and a knowledge of the level of Sr^{90} that may be considered permissible in man. From the data presented, however, it is possible to obtain an understanding of some of the steps in the process leading to possible damage.

Even in the limited field of monitoring, there are many scientific problems that arise in sampling, radiochemical analysis, and data evaluation. These problems are quite apart from the more controversial interpretation of the possible hazard to man: (1) It is first necessary to know, to the required degree of certainty, what the actual levels of Sr^{90} contamination are in various parts of the environment. The sampling should be directed not only toward obtaining an estimate of the average contamination but also toward the probability that much higher than the average values may exist in a small portion of the environment. Fallout is not uniform and possible hazard to relatively small groups of people must be considered; facilities for extensive work of this kind have not been available. (2) The analytical process is extremely involved, requiring the utmost in care and the highest quality in measuring equipment. The radiochemical properties of Sr^{90} and its extremely small concentrations in samples make the analysis a slow process, and, under the best conditions, there is a considerable time lag between sampling and final reporting of results. This is further accentuated by the need for accuracy, which means that a system of checking and cross-checking of all data is a primary requirement. (3) The evaluation mentioned here is merely the consideration of the validity of the analytical data rather than its final interpretation. Such evaluation requires not only a knowledge of the quality of the radiochemical analysis but also a knowledge of how the data received fit into the known pictures of meteorology, soil chemistry, plant uptake, and the like.

The study of long-range fallout has brought many organizations into the field, in the United States and in other countries. These groups operate at widely varied levels of technical competence and frequently with varied concepts of the relative importance of separate portions of the program. A more concerted world-wide effort has been exerted since the inception of the United Nations Scientific Committee on the Effects of Atomic Radiation. The AEC has assisted this Committee by providing AEC data and in the training of laboratory personnel; standard materials for intercomparison of analytical procedures have also been provided. A complete listing of all measurements made on a world-wide basis is, of course, impossible in this report, but references to the appropriate literature are given.

Part 3 of this report presents three bibliographies:

1. Supplement No. 2 to USAEC Report NYO-4753, *Annotated Bibliography on Long-range Effects from Nuclear Explosions*.

2. General bibliography of papers on fallout, particularly Sr⁹⁰ and Cs¹³⁷. This bibliography covers only the period since the Congressional Hearings on fallout. The report on the Congressional Hearings gave a comprehensive bibliography on the subject for papers written up to the Spring of 1957.

3. Bibliography of reports submitted by Member Nations of the United Nations Scientific Committee on the Effects of Atomic Radiation. Although a number of these reports are not generally available, this bibliography indicates the type of material presented for consideration to the Committee.

Part 4, Selected Papers, contains three reports on Sr⁹⁰ and Cs¹³⁷ data from the United Kingdom, reproduced in full through the courtesy of the authors. One of these papers, Report AERE-HP/R.2353, appears in the *Journal of Nuclear Energy*, June 1958. The data from the United Kingdom are in general agreement with those from the United States and Canada for the corresponding periods. No attempt has been made to tabulate these values along with the results from the United States, but comparisons can be made by reference to the tables in Parts 1 and 2 of this report.

A group of reports and speeches from the United States that are not as yet generally available has been reproduced in full. Some of these deal with the interpretation of fallout data, and others deal with more specific experimental work. These papers complete Section 4.

Part 1

FALLOUT MONITORING AND DOCUMENTATION

THIS PAGE
WAS
INTENTIONALLY
LEFT BLANK
IN
ORIGINAL

FALLOUT MONITORING AND DOCUMENTATION

Any prediction of the possible effects of radioactive materials from weapons tests requires a continuing program of monitoring and documentation. Such programs have been in operation in a few countries for several years. Other countries have begun monitoring programs since the formation of the United Nations Scientific Committee on the Effects of Atomic Radiation.

This report is limited chiefly to the tabulation of results obtained in the United States by various laboratories. The studies include measurements of deposition, air concentrations, water concentrations, and uptake.

Some early data based on mixed fission product determinations have been included, since there were very few Sr^{90} measurements made before 1954. For samples collected since that time, however, an attempt has been made to use only radiochemical data, since the interpretation of mixed fission product analyses is very difficult under present conditions of weapons testing.

1. DEPOSITION

The level of fallout deposition on the ground is not a direct measure of hazard to man from radioisotopes such as Sr^{90} or Cs^{137} . For example, Sr^{90} has to pass through the food chain before it can be incorporated into the human body. This passage may consist of several steps, all of them biologically complex. The determination of geographical distribution of fallout, however, is the first step in a scientific study leading to the possibility that unusually high or low concentrations may appear in the food chain or in man himself.

The two important features of deposition are the total accumulated fallout and the fallout rate. The Sr^{90} chain from soil to plants to cattle to milk to humans, for example, is dependent on the accumulated deposit present in the soil. The corresponding chain resulting from retention of fallout on plant surfaces, on the other hand, would be rate dependent. In addition to obtaining data for possible correlation with the uptake of the isotopes by humans, the study of fallout deposition is also important for obtaining a material balance of particular isotopes from the amount produced, the amount deposited, and the amount still in the atmosphere.

The measurement of fallout rate requires collection over relatively short periods, usually on the order of one month, and radiochemical measurement for Sr^{90} . Two types of collectors are in current use—a stainless-steel open vessel or pot and a plastic funnel. These units, when exposed continuously, collect both dry fallout and the material carried down by precipitation. It is also possible to collect the material carried down by individual rainfalls and obtain meteorological information as to the probable atmospheric source of the fallout. Such short term collections may also be analyzed for shorter-lived isotopes to estimate the approximate age of the radioactive debris.

The radiochemical analysis of soils allows direct measurement of fallout accumulated since the start of testing. These analyses, however, are extremely time consuming, complex, and subject to considerable sampling error. They are most useful, therefore, for presenting a broad picture of world-wide fallout rather than for detailed studies.

Although the gummed film technique of deposition measurement allows estimation of Sr^{90} only by calculation from amount of mixed fission products obtained, it has the advantage of simplicity and, therefore, possible operation at a large number of sampling stations.

1.1 POT FALLOUT COLLECTIONS

The Health and Safety Laboratory (HASL), AEC, has set up a network of fallout collection stations using stainless-steel pots with an open area of approximately 1 sq ft. The sampling period is one month, and the pot residues are collected and are analyzed for Sr^{90} . The original collecting station in New York has been in operation since the beginning of 1954, and other stations have been added where laboratory facilities are available for transfer and shipment of the samples. This operation is carried out through the cooperation of scientists at the individual stations.

The present network consists of 13 stations in the continental United States and 17 stations outside the continental United States.

The data for New York City are shown in Table 1 and Fig. 1. The data for other United States stations are given in Table 2. Data for stations outside the continental United States are given in Table 3. (Not all the 30 stations mentioned have submitted samples in time for this report.)

Fallout Monitoring by Other Countries. A number of other countries are reporting radiochemical analyses on pot type samples in submissions to the United Nations Scientific Committee on the Effects of Atomic Radiation. Although several countries are now producing reliable results, the only country, other than the United States, that has released any large number of Sr^{90} analyses is the United Kingdom. Their results are reprinted in Part 4 of this report.

1.2 PRECIPITATION COLLECTIONS FOR RADIOSTRONTIUM AND RADIOBARIUM

The collection and analysis of individual rainfalls was begun at the University of Chicago and later at the laboratories of Nuclear Science Corporation, Pittsburgh, Pa. The latter collection, the most complete set of individual collections, was begun in February 1955. These collections are carried out in duplicate with open vessels having an area of about 2.6 sq ft. They are exposed continuously, and, if a period of one week occurs without rainfall, the vessels are washed out and the residue is analyzed. The cumulative value, therefore, represents the total fallout since the beginning of the collection period.

In addition to Sr^{90} measurements samples taken since the end of August 1957 have also been analyzed for Sr^{89} and Ba^{140} . These analyses can indicate the relative age of fallout debris in a qualitative way. The ratios of the three isotopes are subject to some variation from fractionization and do not follow the theoretical ratios obtained from thermal neutron fission sufficiently well to give exact ages of the radioactive material. This situation is complicated even more by the fact that current fallout is a composite material resulting from many individual weapons tests. The ratios, however, do give a reasonable indication as to whether a particularly high fallout value is probably fresh tropospheric material or older stratospheric material.

The data for both types of analyses are given for Pittsburgh in Table 4 and are plotted in Fig. 2. The earlier Chicago rainfall samples are recorded in Table 5.

1.3 Sr^{90} IN SOIL

Strontium-90 analyses of soils have been made for several years to study geographical distribution and the amount of isotope available for uptake by plant systems. In both cases the measurements can be considered to be for monitoring purposes.

In the geographical studies it is desirable to measure all the Sr^{90} present in the soil per unit area regardless of the depth of penetration or the composition of the soil. Such measurements have been made in this country on soils from the United States and on samples collected in other countries. With the exception of the United Kingdom, other countries are just beginning soil analysis programs; hence foreign samples analyzed in the United States have been for the purpose of documentation until the various countries obtain their own data.

For uptake studies it is desirable to measure the Sr^{90} that is available to the plant and, in addition, to relate this to the available calcium in the soil. Comparative studies have shown that the results from the two techniques are not interchangeable, and the data reported here are exclusively those designed for revealing geographical distribution.

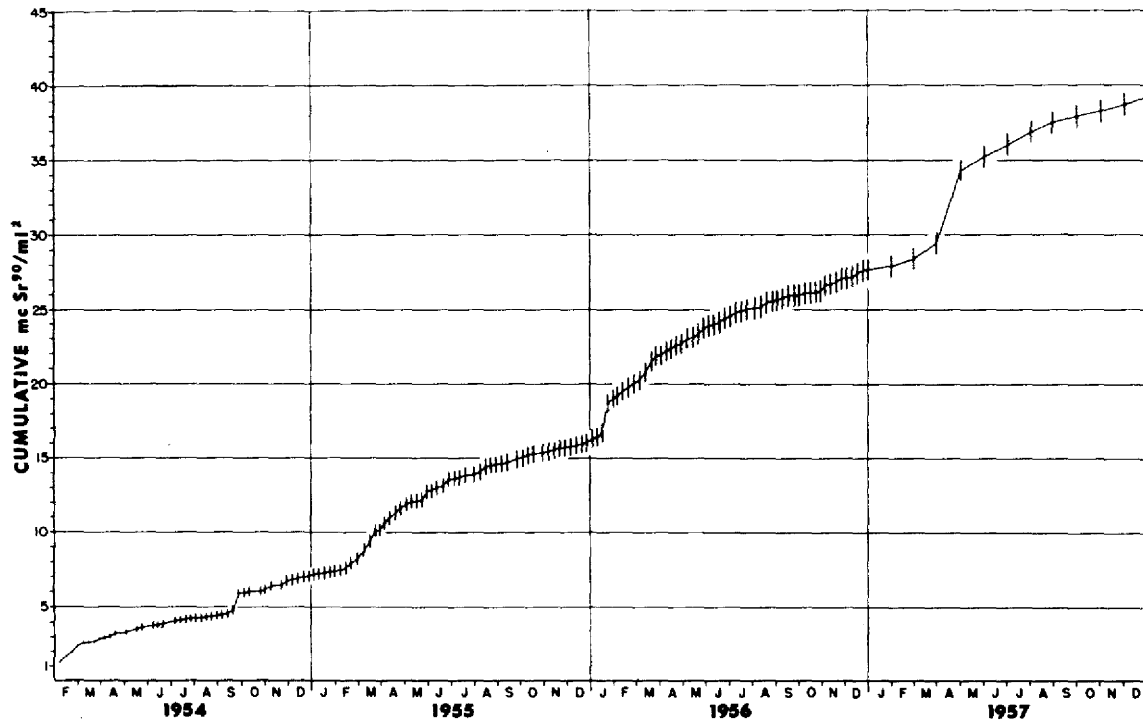

Fig. 1— Sr^{90} in New York City fallout. (High-walled stainless-steel pot collections.)

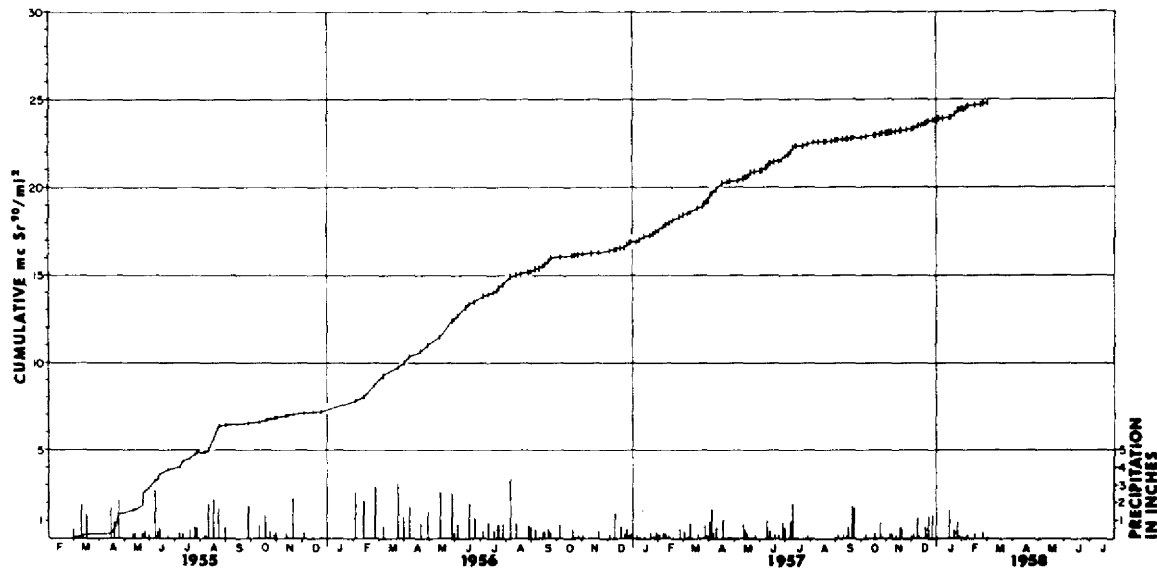

Fig. 2— Sr^{90} in Pittsburgh fallout. (Galvanized tub collections.)

a. *Seventeen Sites Within the Continental United States (1955-1957)*. Yearly collections of soil have been made at 17 sites within the continental United States since 1955. The sites were selected at airports where continuous gummed film sampling has been carried out since 1952. The analyses were intended for comparison with Sr^{90} estimates from gummed film measurements, but they have also provided direct data for fallout within the United States.

The sites were selected without consultation with soil scientists, and it is believed that a few of the airports may not be ideal sampling locations because of soil grading and packing. These sites will be reviewed before collection of future samples.

b. *Measurements made at Lamont Geological Observatory, Columbia University, Palisades, N. Y.* The Lamont Geological Observatory has been carrying out soil analyses for several years. Like other laboratories a considerable portion of their early data was obtained by ammonium acetate leaching of the soil. This is of interest in studies of availability for uptake, but it is of dubious value in studying geographical distribution, since there is considerable variation from soil to soil in the efficiency of the acetate leaching process. Therefore, the data reported here are chiefly limited to samples leached with hydrochloric acid.

c. *Sr^{90} in Soils Collected Outside the United States*. Collections of soil samples have been made in several countries outside the United States for determination of accumulated Sr^{90} fallout. These samples were taken to obtain results for the countries concerned and for comparison with other fallout sampling techniques. In general, the countries sampled were not making their own Sr^{90} measurements at the time, and, even at present, soil analyses are being carried out in very few laboratories.

Soil sampling represents our best method of obtaining cumulative fallout measurements, but the sampling is extremely difficult and is subject to many possible errors. It is sometimes impossible to obtain representative samples because of soil drainage or packing conditions. The samples reported in Table 9 are limited largely to those collected for determination of Sr^{90} fallout per unit area, in which the measurement was made by leaching the soil with hydrochloric acid. A number of early samples were analyzed by leaching with ammonium acetate. Although this may have value in uptake studies, the results are not valid for fallout measurements. These samples have been omitted for the tabulation. It is expected that the number of samples from other countries will be reduced as the particular countries begin their own programs of soil and other fallout analyses.

d. *Sr^{90} in Soil Collected and Analyzed in the United Kingdom*. Annual samples of soil from several sites in the United Kingdom have been collected and analyzed for several years. A description of these sites and the results of the analyses are included in Part 4 of this report.

1.4 SUMMARY OF GUMMED FILM FALLOUT MEASUREMENTS THROUGH JUNE 1957

A primary technique in studying long-range fallout is the measurement of the rate of deposition and the cumulative deposit per unit area. For this purpose, three types of samples are currently used: soil, pot or funnel, and gummed film.

There can be no absolute sampling procedure for fallout deposition because the deposition in a given situation will be influenced by the type of surface. However, the collection performance of the gummed film has been studied in relation to collections by pots to permit some basis of comparison.

In earlier reports it has been shown that the gummed film, under conditions of moderate rainfall in a temperate climate, yields fallout samples with an over-all efficiency of about 63 per cent compared with the values from high-walled pots. In regions where much of the fallout occurs with snow, the gummed film method may grossly underestimate the true fallout values. Despite this objection the gummed film technique has proved desirable because of the simplicity with which daily samples can be accumulated from a large number of widely scattered locations.

Since late 1954 the computation of Sr^{90} from the total beta activity of the gummed film samples has become increasingly difficult because the computed values are sensitive to the assumed age of the debris. The accumulation of long-lived fission products in the stratosphere and the greater frequency of weapons tests has greatly complicated the problem of assigning

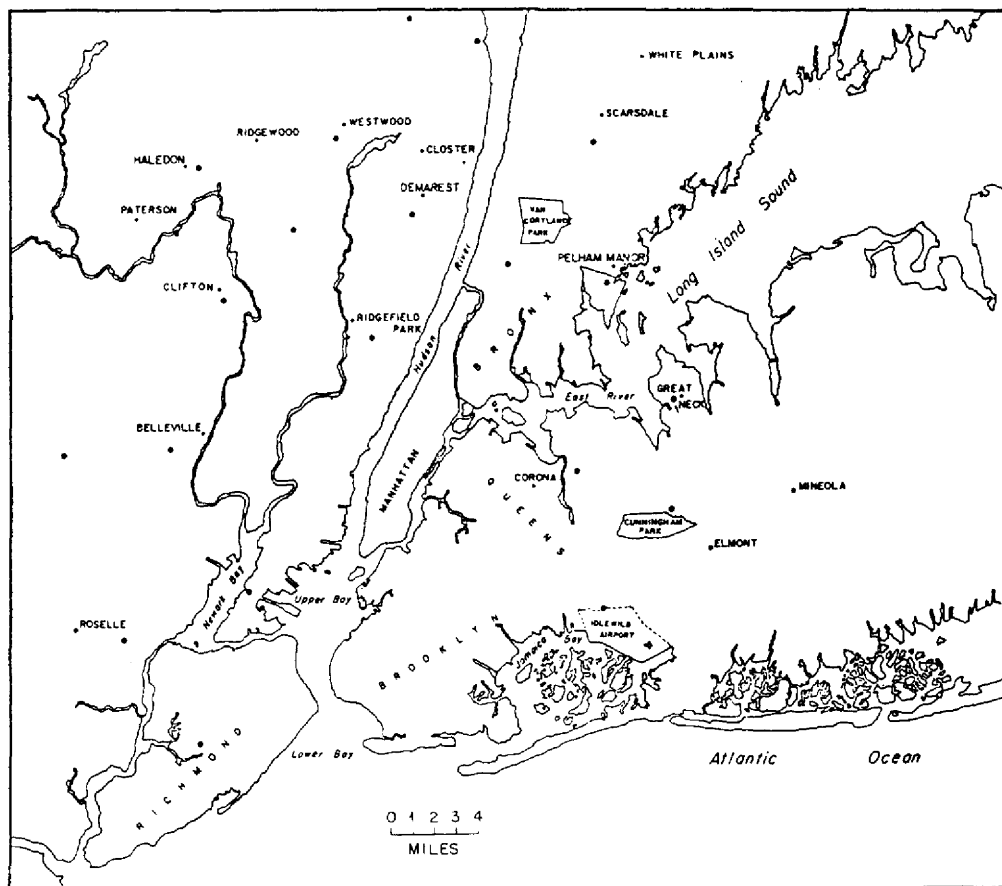

Fig. 3— Location of Lamont Geological Observatory soil sampling sites, 1955.

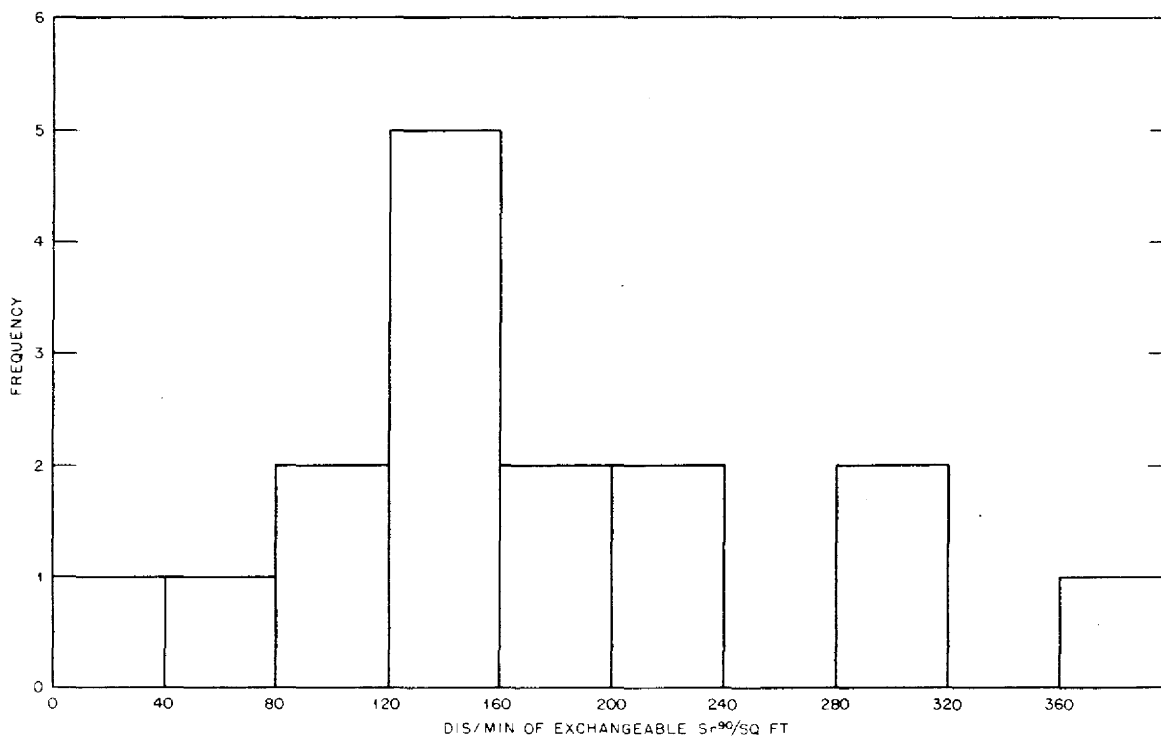

Fig. 4—Histogram of Sr⁹⁰ per square foot for New York soils.

3. The Sr^{90} activity from each test is added to the accumulated Sr^{90} activity from previous tests.
4. For each sampling day the Sr^{90} to total fission product activity ratio is calculated.
5. Each day's measured beta activity is converted to Sr^{90} activity by use of this factor.

This method of calculation would give high strontium values for locations near test sites on days of high fallout. This is caused by attributing the activity to the total accumulated pool of fission products rather than to the immediate burst that caused the fallout. This can be corrected by treating these few cases individually.

The only practical evaluation of the new calculations technique is by comparison with radiochemical analyses of open samplers. During the period May 1956–June 1957, several locations had parallel sampling units for at least part of the time. These data are shown in the following table in which one finds that the gummed film system, together with the above method of computation, yields estimates of Sr^{90} deposition which tend to be higher than the estimates derived by radiochemical analyses of pot samples. The mean ratio of Sr^{90} estimated from gummed film to pot analyses is 1.45 with a maximum ratio of 1.66 at Salt Lake City and a minimum of 0.90 in New York City.

COMPARISON OF Sr^{90} ESTIMATES FROM GUMMED FILM
WITH RADIOCHEMICAL ANALYSES OF MONTHLY POT COLLECTIONS

Location	Period of observation	Total Sr^{90} , mc/sq. mile		Film/pot ratio	Monthly ratios		Film/pot mean
		Film	Pots		Low	High	
New York City	May 1956–June 1957	12.3	13.7	0.90	0.32	2.2	1.1
Pittsburgh	May 1956–June 1957	12.1	10.6	1.14	0.62	2.5	1.2
Chicago	Dec. 1956–June 1957	6.3	4.6	1.37	1.0	1.9	1.4
Salt Lake City	Dec. 1956–June 1957	15.1	9.1	1.66	1.1	3.3	1.8
Los Angeles	Dec. 1956–June 1957	3.5	3.1	1.13	0.78	2.4	1.4
Hiroshima	Oct. 1956–June 1957	5.6	3.7	1.51	0.82	3.7	1.7
Nagasaki	Aug. 1956–June 1957	6.7	5.5	1.22	0.64	5.5	1.6

The calculation of external gamma dose is less sensitive to variations in the source of fallout. In addition, it appears that the important gamma dose from fission products is from internal Cs^{137} rather than the external gamma from distributed fission products after suitable allowance for shielding and weathering.



Fig. 6 — Cumulative world-wide Sr^{90} deposition as of June 1957, gummed film measurements.

Table 1—POT FALLOUT COLLECTIONS, NEW YORK CITY

Collection period	Sr ⁹⁰ /sq mile, mc	Cumulative Sr ⁹⁰ /sq mile, mc	Sr ⁸⁹ /Sr ⁹⁰ *	Precipitation, in.
1954				
2/1-2/8	1.3 ± 0.031	1.3 ± 0.031		0.31
2/8-2/15	0.35 ± 0.025	1.65 ± 0.040		0.05
2/15-2/23	0.32 ± 0.015	1.97 ± 0.043		1.29
2/23-3/1	0.40 ± 0.031	2.37 ± 0.053		0.16
3/1-3/8	0.20 ± 0.033	2.57 ± 0.062		1.28
3/8-3/15	0.060 ± 0.019	2.63 ± 0.065		0.81
3/15-3/22	0.075 ± 0.048	2.70 ± 0.081		0.69
3/22-3/29	0.18 ± 0.075	2.88 ± 0.11		0.44
3/29-4/5	0.075 ± 0.075	2.96 ± 0.13		0.06
4/5-4/12	0.083 ± 0.083	3.04 ± 0.16		0.51
4/12-4/19	0.18 ± 0.08	3.22 ± 0.18		1.63
4/19-4/26	Sample lost			0.35
4/26-5/3	0.15 ± 0.08	3.37 ± 0.19		0.18
5/3-5/10	Sample lost			1.88
5/10-5/17	0.18 ± 0.08	3.55 ± 0.21		0.26
5/17-5/24	0.15 ± 0.08	3.70 ± 0.22		0.88
5/24-5/31	Sample lost			0.08
5/31-6/8	0.10 ± 0.046	3.80 ± 0.23		0.11
6/8-6/14	0.074 ± 0.033	3.88 ± 0.23		0.52
6/14-6/21	0.075 ± 0.075	3.95 ± 0.24		0
6/21-6/28	Sample lost			0.59
6/28-7/5	0.21 ± 0.070	4.16 ± 0.25		0.35
7/5-7/12	0.033 ± 0.033	4.20 ± 0.26		0.22
7/12-7/19	0.033 ± 0.033	4.23 ± 0.26		0.37
7/19-7/26	0.045 ± 0.033	4.27 ± 0.26		0
7/26-8/2	0.033 ± 0.033	4.31 ± 0.26		0.12
8/2-8/9	0.038 ± 0.038	4.34 ± 0.26		0.83
8/9-8/16	0.053 ± 0.053	4.40 ± 0.27		1.88
8/16-8/23	0.053 ± 0.053	4.45 ± 0.27		1.67
8/23-8/30	0.050 ± 0.050	4.50 ± 0.28		0
8/30-9/6	0.073 ± 0.046	4.57 ± 0.28		1.71
9/6-9/13	0.044 ± 0.044	4.62 ± 0.29		3.57
9/13-9/20	0.21 ± 0.050	4.83 ± 0.29		0.94
9/20-9/27	1.1 ± 0.073	5.93 ± 0.30		0.23
9/27-10/4	0.046 ± 0.046	5.97 ± 0.30		0.07
10/4-10/11	0.055 ± 0.050	6.03 ± 0.31		0.04
10/11-10/18	Sample lost			0.37
10/18-10/25	0.038 ± 0.038	6.07 ± 0.31		0.02
10/25-11/1	0.10 ± 0.080	6.17 ± 0.32		1.50
11/1-11/8	0.24 ± 0.055	6.41 ± 0.32		1.95
11/8-11/15	Sample lost			0
11/15-11/22	0.073 ± 0.055	6.48 ± 0.33		2.05
11/22-11/27	0.26 ± 0.044	6.74 ± 0.33		0.35
11/27-12/6	0.078 ± 0.078	6.82 ± 0.34		0.58
12/6-12/13	0.073 ± 0.073	6.89 ± 0.35		0.50
12/13-12/20	0.099 ± 0.099	6.99 ± 0.36		1.29
12/20-12/27	0.065 ± 0.063	7.05 ± 0.37		0
12/27-1/3/55	0.10 ± 0.055	7.15 ± 0.37		1.55

Table 1 (Continued)

Collection period	Sr ⁹⁰ /sq mile, mc	Cumulative Sr ⁹⁰ /sq mile, mc	Sr ⁸⁸ /Sr ⁹⁰ *	Precipitation, in.
1955				
1/3-1/10	0.053 ± 0.053	7.21 ± 0.38		0.26
1/10-1/17	0.053 ± 0.053	7.26 ± 0.38		0.14
1/17-1/24	0.068 ± 0.053	7.33 ± 0.38		0.05
1/24-2/1	0.055 ± 0.055	7.38 ± 0.39		0.01
2/1-2/7	0.055 ± 0.055	7.44 ± 0.38		1.55
2/7-2/14	0.17 ± 0.17	7.61 ± 0.43		0.49
2/14-2/21	0.34 ± 0.063	7.95 ± 0.43		0.38
2/21-3/1	0.30 ± 0.060	8.25 ± 0.44		0.59
3/1-3/7	0.60 ± 0.082	8.85 ± 0.44		1.32
3/7-3/14	0.56 ± 0.064	9.41 ± 0.45		0.03
3/14-3/21	0.73 ± 0.078	10.14 ± 0.45		0.56
3/21-3/28	0.060 ± 0.060	10.20 ± 0.46		1.80
3/28-4/4	0.48 ± 0.11	10.68 ± 0.46		0.04
4/4-4/11	0.31 ± 0.072	10.99 ± 0.48		0.29
4/11-4/18	0.34 ± 0.057	11.33 ± 0.48		0.32
4/18-4/25	0.33 ± 0.063	11.66 ± 0.48		0.53
4/25-5/2	0.26 ± 0.063	11.92 ± 0.49		0.79
5/2-5/9	0.17 ± 0.055	12.09 ± 0.49		0.22
5/9-5/16	0.055 ± 0.055	12.14 ± 0.49		0
5/16-5/23	0.065 ± 0.057	12.21 ± 0.50		0
5/23-5/30	0.60 ± 0.068	12.81 ± 0.50		1.80
5/30-6/6	0.050 ± 0.050	12.86 ± 0.50		0.92
6/6-6/13	0.21 ± 0.068	13.07 ± 0.51		0.40
6/13-6/20	0.087 ± 0.053	13.16 ± 0.51		0.02
6/20-6/27	0.48 ± 0.068	13.64 ± 0.52		1.80
6/27-7/4	0.050 ± 0.050	13.68 ± 0.52		0.20
7/4-7/11	0.035 ± 0.035	13.72 ± 0.52		0.29
7/11-7/18	0.17 ± 0.068	13.89 ± 0.52		0
7/18-7/25	Sample lost			0.02
7/25-8/1	0.043 ± 0.043	13.93 ± 0.53		0
8/1-8/8	0.19 ± 0.099	14.12 ± 0.54		1.00
8/8-8/15	0.38 ± 0.060	14.50 ± 0.54		7.33
8/15-8/22	0.053 ± 0.048	14.56 ± 0.54		2.36
8/22-8/29	0.056 ± 0.056	14.61 ± 0.54		0.06
8/29-9/5	0.056 ± 0.056	14.67 ± 0.55		0.11
9/5-9/12	0.078 ± 0.078	14.75 ± 0.55		0.08
9/12-9/19	Sample lost			0
9/19-9/26	0.19 ± 0.064	14.94 ± 0.56		1.60
9/26-10/3	0.099 ± 0.063	15.04 ± 0.56		0.99
10/3-10/10	0.20 ± 0.064	15.24 ± 0.56		2.92
10/10-10/17	0.094 ± 0.063	15.32 ± 0.57		2.45
10/17-10/24	Sample lost			0.24
10/24-10/31	0.063 ± 0.063	15.39 ± 0.57		1.26
10/31-11/7	0.063 ± 0.063	15.46 ± 0.57		1.57
11/7-11/14	0.064 ± 0.064	15.52 ± 0.58		0.74
11/14-11/21	0.16 ± 0.064	15.68 ± 0.58		1.76
11/21-11/28	0.063 ± 0.063	15.74 ± 0.58		0.05
11/28-12/5	0.068 ± 0.068	15.81 ± 0.59		0.06
12/5-12/12	0.092 ± 0.072	15.90 ± 0.59		0
12/12-12/19	0.083 ± 0.056	15.98 ± 0.60		0
12/19-12/26	0.068 ± 0.068	16.05 ± 0.60		0.16
12/26-1/3/56	0.31 ± 0.064	16.36 ± 0.60		0.03

Table 1 (Continued)

Collection period	Sr ⁹⁰ /sq mile, mc	Cumulative Sr ⁹⁰ /sq mile, mc	Sr ⁸⁹ /Sr ⁹⁰ *	Precipitation, in.
1956				
1/3-1/9	0.10 ± 0.056	16.47 ± 0.60		0.11
1/9-1/16	0.29 ± 0.080	16.78 ± 0.61		0.71
1/16-1/23	2.01 ± 0.089	18.77 ± 0.62		0.05
1/23-1/30	0.30 ± 0.060	19.07 ± 0.62		0.15
1/30-2/6	0.19 ± 0.060	19.26 ± 0.62		1.23
2/6-2/13	0.32 ± 0.064	19.57 ± 0.62		1.30
2/13-2/20	0.23 ± 0.056	19.80 ± 0.63		1.23
2/20-2/27	0.28 ± 0.063	20.08 ± 0.63		0.49
2/27-3/5	0.25 ± 0.073	20.33 ± 0.64		0.59
3/5-3/12	0.51 ± 0.080	20.84 ± 0.64		1.21
3/12-3/19	0.73 ± 0.083	21.56 ± 0.65		2.46
3/19-3/26	0.30 ± 0.068	21.87 ± 0.65		0.89
3/26-4/2	0.073 ± 0.070	21.94 ± 0.65		0.33
4/2-4/9	0.30 ± 0.070	22.23 ± 0.66		1.61
4/9-4/16	0.18 ± 0.080	22.41 ± 0.66		0.33
4/16-4/23	0.20 ± 0.080	22.61 ± 0.67		0.43
4/23-4/30	0.099 ± 0.080	22.71 ± 0.67		0.29
4/30-5/7	0.38 ± 0.070	23.09 ± 0.68		1.12
5/7-5/14	0.068 ± 0.068	23.16 ± 0.68		0.23
5/14-5/21	0.21 ± 0.080	23.37 ± 0.68		0.37
5/21-5/28	0.38 ± 0.070	23.75 ± 0.69		0.48
5/28-6/4	0.18 ± 0.070	23.92 ± 0.69		1.57
6/4-6/11	0.070 ± 0.070	23.99 ± 0.69		0.07
6/11-6/18	0.14 ± 0.070	24.13 ± 0.70		0.07
6/18-6/25	0.28 ± 0.080	24.41 ± 0.70		0.67
6/25-7/2	0.14 ± 0.080	24.55 ± 0.71		0.73
7/2-7/9	0.26 ± 0.07	24.81 ± 0.71		0.70
7/9-7/16	0.080 ± 0.066	24.89 ± 0.71		0.53
7/16-7/23	Sample lost			1.37
7/23-7/30	0.089 ± 0.055	25.01 ± 0.71		0.53
	0.15 ± 0.060			
7/30-8/6	0.12 ± 0.069	25.13 ± 0.72		0.05
8/6-8/13	0.067 ± 0.067	25.20 ± 0.72		0.77
8/13-8/20	0.30 ± 0.072	25.50 ± 0.72		0.35
8/20-8/27	0.067 ± 0.067	25.56 ± 0.73		0.98
8/27-9/3	0.067 ± 0.067	25.66 ± 0.73		0.65
	0.12 ± 0.06			
9/3-9/10	0.067 ± 0.067	25.75 ± 0.73		0.74
	0.11 ± 0.06			
9/10-9/17	0.12 ± 0.07	25.94 ± 0.73		0.63
	0.26 ± 0.07			
9/17-9/24	0.020 ± 0.020	25.96 ± 0.73		0.36
	0.019 ± 0.019			
9/24-10/1	0.024 ± 0.012	25.98 ± 0.73		0.35
	0.014 ± 0.014			
10/1-10/8	0.19 ± 0.019	26.13 ± 0.73		0.55
	0.12 ± 0.018			
10/8-10/15	0.037 ± 0.020	26.16 ± 0.73		0
	0.020 ± 0.020			

Table 1 (Continued)

Collection period	Sr ⁹⁰ /sq mile, mc	Cumulative Sr ⁹⁰ /sq mile, mc	Sr ⁸⁹ /Sr ⁹⁰ *	Precipitation, in.
10/15-10/22	0.055 ± 0.015	26.21 ± 0.73		0.02
	0.044 ± 0.015			
10/22-10/29	0.089 ± 0.014	26.29 ± 0.73		0.63
	0.070 ± 0.014			
10/29-11/5	0.64 ± 0.035	26.67 ± 0.73		3.18
	0.12 ± 0.020			
11/5-11/12	0.065 ± 0.018	26.74 ± 0.73		0.11
	0.088 ± 0.014			
11/12-11/19	0.071 ± 0.021	26.88 ± 0.73		0.95
	0.21 ± 0.025			
11/19-11/26	0.18 ± 0.028	27.13 ± 0.73		0.69
	0.31 ± 0.031			
11/26-12/3	0.019 ± 0.012	27.18 ± 0.73		0.10
	0.075 ± 0.016			
12/3-12/10	0.095 ± 0.018	27.27 ± 0.73		0.57
	0.090 ± 0.018			
12/10-12/17	0.28 ± 0.022	27.52 ± 0.73		1.76
	0.22 ± 0.022			
12/17-12/24	0.15 ± 0.02	27.70 ± 0.73		0.59
	0.20 ± 0.02			
12/24-12/31	0.03 ± 0.01	27.73 ± 0.73		0.37
	0.04 ± 0.02			
12/31-1/31/57	0.32 ± 0.02	28.00 ± 0.73	26	1.57
	0.21 ± 0.02		23	
1957				
1/31-2/28	0.56 ± 0.03	28.52 ± 0.73	20	2.50
	0.49 ± 0.03		21	
2/28-3/31	1.01 ± 0.013	29.56 ± 0.73		2.05
	1.06 ± 0.013			
3/31-4/30	6.66 ± 0.22	34.37 ± 0.74		4.51
	2.95 ± 0.016			
4/30-5/31	0.95 ± 0.04	35.30 ± 0.74	7.4	3.67
	0.93 ± 0.04		17	
5/31-6/28	0.78 ± 0.04	36.12 ± 0.74	28	1.66
	0.86 ± 0.06		28	
6/28-8/1	1.22 ± 0.05	36.96 ± 0.74	11	1.66
	0.46 ± 0.03		25	
8/1-8/31	0.50	37.46 ± 0.74	59	2.87
9/1-9/31	0.41	37.87 ± 0.74	47	3.01
10/1-10/31	0.38	38.25 ± 0.74	61	3.27
11/1-11/31	0.42	38.67 ± 0.75	21	4.46
12/1-12/31	0.60	39.27 ± 0.75	20	5.26

* Extrapolated to middle of sampling period.

Table 2—MONTHLY POT FALLOUT COLLECTIONS AT OTHER UNITED STATES LOCATIONS

Collection period	Sr ⁹⁰ /sq mile, mc	Cumulative Sr ⁹⁰ /sq mile, mc	Sr ⁸⁹ /Sr ⁹⁰ *	Precipitation, in.
<i>Lemont, Ill.</i>				
Dec. 1956	0.14 ± 0.02	0.14 ± 0.02	18	1.26
Jan. 1957	0.30 ± 0.02	0.44 ± 0.03	15	2.06
Feb. 1957	0.27 ± 0.01	0.71 ± 0.03		1.77
Mar. 1957	0.47 ± 0.04	1.18 ± 0.05		1.98
Apr. 1957	1.15 ± 0.01	2.33 ± 0.05		6.09
May 1957	0.27 ± 0.02	2.60 ± 0.06	8.3	3.21
June 1957	0.48 ± 0.03	3.08 ± 0.06	17	5.94
July 1957	1.567 ± 0.012	4.649 ± 0.064		8.98
Aug. 1957	0.747 ± 0.008	5.396 ± 0.065		5.36
Sept. 2–Oct. 7, 1957	0.123 ± 0.010	5.519 ± 0.065	62	1.08
Oct. 7–Nov. 11, 1957	0.218 ± 0.013	5.737 ± 0.067	28	
Nov. 11–Dec. 19, 1957	0.198 ± 0.012	5.935 ± 0.069	14	
<i>Birmingham, Ala.</i>				
Apr. 1957	0.83 ± 0.02	0.83 ± 0.02		5.41
May 1957	0.39 ± 0.03	1.22 ± 0.04	9.4	2.96
June 1957	0.950 ± 0.061	2.170 ± 0.071	31	7.70
July 1957	0.799 ± 0.088	2.969 ± 0.093		2.62
Aug. 1957	1.103 ± 0.061	4.072 ± 0.112	8.4	4.19
Sept. 1957	0.421 ± 0.043	4.493 ± 0.120	67	9.59
Oct. 1957	0.342 ± 0.018	4.835 ± 0.121	75	
Nov. 1957	0.221 ± 0.017	5.050 ± 0.122	20	
Dec. 1957†				
<i>Salt Lake City, Utah</i>				
Dec. 1956	0.31 ± 0.02	0.31 ± 0.02		1.67
Jan. 1957	0.8 ± 0.1	1.11 ± 0.10	16	1.37
Feb. 1957	0.83 ± 0.04	1.94 ± 0.11	14	0.72
Mar. 1957	2.39 ± 0.09	4.33 ± 0.14	9.3	2.18
Apr. 1957	2.30 ± 0.01	6.63 ± 0.14		3.24
May 1957	0.81 ± 0.03	7.44 ± 0.14	1.3	3.37
June 1957	1.61 ± 0.061	9.05 ± 0.16	24	1.47
July 1957	0.941 ± 0.093	9.991 ± 0.187		0.31
Aug. 1957	1.277 ± 0.015	11.268 ± 0.187		1.69
Sept. 1957	0.150 ± 0.015	11.418 ± 0.187	40	0.33
Oct. 1957	0.590 ± 0.029	12.008 ± 0.187	49	
Nov. 1957	0.409 ± 0.023	12.417 ± 0.187	15	
Dec. 1957	0.643 ± 0.031	13.060 ± 0.190	12	
<i>Vermillion, S. Dak.</i>				
Apr. 1957	0.51 ± 0.01	0.51 ± 0.01		1.35
May 1957	1.74 ± 0.05	2.25 ± 0.05	11	4.17
June 1957	1.01 ± 0.05	3.26 ± 0.07	25	2.37
July 1957	2.803 ± 0.138	6.063 ± 0.154	68	4.29
Aug. 1957	1.106 ± 0.014	7.169 ± 0.155		1.62
Sept. 1957	0.873 ± 0.077	8.042 ± 0.173	33	3.14
Oct. 1957	0.934 ± 0.061	8.976 ± 0.183	51	1.67
Nov. 1957	0.142 ± 0.009	9.118 ± 0.183	15	
Dec. 1957	0.060 ± 0.011	9.178 ± 0.185	16	

Table 2 (Continued)

Collection period	Sr ⁹⁰ /sq mile, mc	Cumulative Sr ⁹⁰ /sq mile, mc	Sr ⁸⁹ /Sr ⁹⁰ *	Precipitation, in.
<i>West Los Angeles, Calif.</i>				
Dec. 1956	0.15 ± 0.02	0.15 ± 0.02	44	0.49
Jan. 1957	0.99 ± 0.04	1.14 ± 0.05	15	3.88
Feb. 1957	0.76 ± 0.01	1.90 ± 0.05		1.94
Mar. 1957	0.09 ± 0.01	1.99 ± 0.05		0.95
Apr. 1957	0.84 ± 0.01	2.83 ± 0.05		1.33
May 1957	0.24 ± 0.02	3.07 ± 0.05	15	0.27
June 1957	0.121 ± 0.044	3.191 ± 0.068	13	0.06
July 1957	0.919 ± 0.061	4.110 ± 0.091	0.9	0.03
Aug. 1957	0.054 ± 0.009	4.164 ± 0.092	4.0	0
Sept. 1957	0.043 ± 0.004	4.207 ± 0.094	6.9	0
Oct. 1957	0.262 ± 0.014	4.469 ± 0.094	17	
Nov. 1957	0.270 ± 0.014	4.739 ± 0.094	18	
Dec. 1957†				
<i>Coral Gables, Fla.</i>				
Apr. 1957	0.53 ± 0.01	0.53 ± 0.01		5.04
May 1957	0.496 ± 0.034	1.026 ± 0.035	19	10.11
June 4–July 12, 1957	0.561 ± 0.024	1.587 ± 0.042	36	5.82
July 12–Aug. 6, 1957	1.511 ± 0.011	3.098 ± 0.044		8.54
Aug. 6–Sept. 6, 1957	0.753 ± 0.031	3.851 ± 0.054	58	13.62
Sept. 6–Oct. 6, 1957	0.521 ± 0.029	4.372 ± 0.061	40	6.27
Oct. 6–Nov. 6, 1957	0.408 ± 0.020	4.708 ± 0.064	48	3.98
Nov. 6–Dec. 6, 1957	0.294 ± 0.018	5.002 ± 0.067	16	
Dec. 6, 1957–Jan. 6, 1958	0.628 ± 0.031	5.630 ± 0.073	15	
<i>Pittsburgh, Pa.</i>				
July 3–July 31, 1957	0.76 ± 0.05	0.75 ± 0.05		4.51
	0.74 ± 0.05			
July 31–Sept. 3, 1957	0.139 ± 0.013	0.886 ± 0.075		0.49
	0.132 ± 0.012			
Sept. 3–Oct. 1, 1957	0.110 ± 0.008	1.020 ± 0.081	58	4.62
	0.158 ± 0.011		32	
Oct. 1–Nov. 1, 1957	0.244 ± 0.012	1.256 ± 0.082	30	1.94
	0.288 ± 0.014		31	
Nov. 1–Dec. 1, 1957	0.38 ± 0.02	1.501 ± 0.085	6.8	2.17
	0.110 ± 0.008		25	
Dec. 1–Jan. 1, 1958	0.57 ± 0.03	2.041 ± 0.090	14	4.93
	0.51 ± 0.03		16	
<i>Westwood, N. J.</i>				
Aug. 1957	1.310 ± 0.011	1.105 ± 0.009		
	0.900 ± 0.009			
Sept. 1957	1.067 ± 0.013	2.282 ± 0.016		
	1.288 ± 0.013			
Oct. 1957	0.948 ± 0.009	3.088 ± 0.018		
	0.663 ± 0.010			
Nov. 1957	0.597 ± 0.012	3.640 ± 0.023		
	0.506 ± 0.010			
Dec. 1957	0.965 ± 0.015	4.780 ± 0.028		
	1.315 ± 0.017			

*Sr⁸⁹ value extrapolated to middle of sampling period.

† In process.

Table 3—MONTHLY POT FALLOUT COLLECTIONS AT LOCATIONS
OUTSIDE THE UNITED STATES

Collection period	Sr ⁹⁰ /sq mile, mc	Cumulative Sr ⁹⁰ /sq mile, mc	Precipitation, in.
<i>Oahu, Hawaii (AEC Lab., Coconut Island)</i>			
June 1957	0.720 ± 0.031	0.720 ± 0.031	0.32
July 1957	1.364 ± 0.107	2.084 ± 0.111	2.10
Aug. 1957	0.303 ± 0.021	2.378 ± 0.113	1.57
Sept. 1957	0.274 ± 0.023	2.661 ± 0.116	1.54
Oct. 1957	0.368 ± 0.023	3.029 ± 0.118	
Oct. 31–Dec. 3, 1957	1.18 ± 0.06	4.209 ± 0.132	6.37
Dec. 4, 1957–Jan. 6, 1958	0.61 ± 0.03	4.819 ± 0.136	
<i>Oahu, Hawaii (Weather Station, Coconut Island)</i>			
July 1957	0.477 ± 0.011	0.477 ± 0.011	2.10
Aug. 1957	0.156 ± 0.008	0.633 ± 0.014	1.57
Sept. 1957	0.188 ± 0.011	0.821 ± 0.017	1.54
Oct. 1957	0.406 ± 0.038	1.277 ± 0.041	
Oct. 31–Dec. 3, 1957	0.897 ± 0.043	2.106 ± 0.060	6.37
Dec. 4, 1957–Jan. 6, 1958	1.82 ± 0.021	3.926 ± 0.023	
<i>Oahu, Hawaii (Gartley Hall, University of Hawaii, Honolulu)</i>			
June 1957	0.582 ± 0.077	0.582 ± 0.077	0.83
July 1957	0.420 ± 0.032	1.002 ± 0.084	1.62
Aug. 1957	0.306 ± 0.034	1.308 ± 0.090	3.09
Sept. 1957	0.159 ± 0.014	1.467 ± 0.090	0.62
Oct. 1957	0.126 ± 0.009	1.593 ± 0.091	
Nov. 1–Dec. 3, 1957	0.643 ± 0.031	2.236 ± 0.097	4.87
Dec. 4, 1957–Jan. 6, 1958	0.574 ± 0.028	2.810 ± 0.100	
<i>Karachi, Pakistan*</i>			
Jan. 1957	0.08 ± 0.02	0.08 ± 0.02	0
Feb. 1957	Sample not collected		0
Mar. 1957	0.08 ± 0.01		
<i>Bangkok, Thailand†</i>			
Mar. 1957	0.05 ± 0.01	0.05 ± 0.01	1.95
Apr. 1957	0.13 ± 0.02	0.18 ± 0.02	5.85
May 1957	0.037 ± 0.020	0.217 ± 0.030	1.56
June 1957	0.016 ± 0.016	0.233 ± 0.034	9.36
July 1957	0.022 ± 0.007	0.255 ± 0.034	6.63
Aug. 1957	0.039 ± 0.004	0.294 ± 0.035	11.70
Sept. 1957	0.066 ± 0.008	0.360 ± 0.036	17.55
Oct. 1957	0.015 ± 0.004	0.375 ± 0.036	16.38
Nov. 1957	0.009 ± 0.004	0.384 ± 0.036	
Dec. 1957	Sample not collected		0
<i>Nagasaki, Japan</i>			
Aug. 1956	0.34 ± 0.02	0.34 ± 0.02	17.43
Sept. 1956	0.17 ± 0.02	0.51 ± 0.03	16.07
Oct. 1956	0.2 ± 0.02	0.71 ± 0.04	3.59
Nov. 1956	0.08 ± 0.02	0.79 ± 0.04	1.44
Dec. 1956	0.22 ± 0.02	1.01 ± 0.04	1.37

Table 3 (Continued)

Collection period	Sr ⁹⁰ /sq mile, mc	Cumulative Sr ⁹⁰ /sq mile, mc	Precipitation, in.
Jan. 1957	1.01 ± 0.02	2.02 ± 0.05	3.94
Feb. 1957	0.17 ± 0.05	2.19 ± 0.05	3.28
Mar. 1957	0.38 ± 0.03	2.57 ± 0.06	1.40
Apr. 1957	1.98 ± 0.02	4.55 ± 0.06	11.27
May 1957	0.720 ± 0.031	5.270 ± 0.068	6.44
June 1957	0.271 ± 0.038	5.541 ± 0.079	10.18
July 1957	1.072 ± 0.122	6.613 ± 0.145	28.67
Aug. 1957	0.457 ± 0.007	7.070 ± 0.145	11.35
Sept. 1957	0.260 ± 0.012	7.330 ± 0.145	14.74
Oct. 1957	0.206 ± 0.018	7.536 ± 0.148	2.11
Nov. 1957	0.193 ± 0.012	7.729 ± 0.148	
Dec. 1957	0.170 ± 0.018	7.899 ± 0.150	
<i>Hiroshima, Japan</i>			
Aug. 1956	0.50 ± 0.03	0.50 ± 0.03	11.93
Sept. 1956	Lost		9.83
Oct. 1956	0.27 ± 0.03	0.77 ± 0.04	3.51
Nov. 1956	0.11 ± 0.02	0.88 ± 0.05	1.64
Dec. 1956	0.06 ± 0.02	0.94 ± 0.05	0.23
Jan. 1957	0.29 ± 0.01	1.23 ± 0.05	2.15
Feb. 1957	0.53 ± 0.01	1.76 ± 0.05	2.26
Mar. 1957	0.23 ± 0.01	1.99 ± 0.05	1.29
Apr. 1957	1.12 ± 0.01	3.11 ± 0.06	11.00
May 1957	0.567 ± 0.077	3.677 ± 0.094	6.44
June 1957	0.493 ± 0.036	4.170 ± 0.110	10.22
July 1957	0.817 ± 0.017	4.987 ± 0.111	21.10
Aug. 1957	0.047 ± 0.009	5.034 ± 0.112	4.48
Sept. 1957	0.277 ± 0.015	5.311 ± 0.113	10.92
Oct. 1957	Lost at the collecting station		2.07
Nov. 1957	0.135 ± 0.012	5.446 ± 0.114	
Dec. 1957	0.358 ± 0.022	5.804 ± 0.115	
<i>Rio de Janeiro, Brazil</i>			
Sept. 1956	0.12 ± 0.02	0.12 ± 0.02	1.95
Oct. 1956	0.21 ± 0.06	0.33 ± 0.06	3.12
Nov. 1956	0.06 ± 0.01	0.39 ± 0.06	3.51
Dec. 1956	0.02 ± 0.02	0.41 ± 0.07	3.51
Jan. 1957	0.04 ± 0.01	0.45 ± 0.07	2.73
Feb. 1957	0.05 ± 0.01	0.50 ± 0.07	5.07
<i>Bogota, Columbia</i>			
Aug. 1957	0.018 ± 0.006	0.018 ± 0.006	
Sept. 1957	0.017 ± 0.008	0.035 ± 0.010	
Oct. 1957	In process		
Nov. 1957	Sample not received		
Dec. 1957	In process		

Table 3 (Continued)

Collection period	Sr ⁹⁰ /sq mile, mc	Cumulative Sr ⁹⁰ /sq mile, mc	Precipitation, in.
<i>Salisbury, South Rhodesia</i> †			
Nov. 1956	0.18 ± 0.02	0.18 ± 0.02	7.41
Dec. 1956	0.12 ± 0.02	0.30 ± 0.03	7.80
Jan. 1957	0.11 ± 0.02	0.41 ± 0.04	5.85
Feb. 1957	0.08 ± 0.01	0.49 ± 0.04	8.97
Mar. 1957	0.05 ± 0.01	0.54 ± 0.04	5.46
Apr. 1957	0.04 ± 0.04	0.58 ± 0.06	1.17
May 1957	Sample not collected		0.78
June 1957	Sample not collected		0.02
July 1957	Sample not collected		0
Aug. 1957	Sample not collected		0.39
Sept. 1957	Sample not collected		0.39
Oct. 1957	Sample not collected		0.78
Nov. 1957	0.109 ± 0.014		
Dec. 1957	0.099 ± 0.021		
<i>Kikuyu, Kenya</i>			
Jan. 1957	0.14 ± 0.02	0.14 ± 0.02	9.75
Feb. 1957	0.26 ± 0.01	0.40 ± 0.02	2.34
Mar. 1957	0.03 ± 0.01	0.43 ± 0.02	3.12
Apr. 1957	0.03 ± 0.01	0.46 ± 0.03	7.02
May 1957	0.138 ± 0.023	0.598 ± 0.035	14.82
June 1957	0.187 ± 0.058	0.783 ± 0.068	1.56
July 1957	0.148 ± 0.007	0.933 ± 0.068	0.08
Aug. 1957	0.020 ± 0.004	0.953 ± 0.068	0.20
Sept. 1957	0.038 ± 0.008	0.991 ± 0.069	2.34
Oct. 1957	0.087 ± 0.006	1.078 ± 0.069	1.56
Nov. 1957	0.055 ± 0.011	1.133 ± 0.070	
Dec. 1957	0.162 ± 0.011	1.295 ± 0.070	
<i>Dakar, French West Africa</i>			
July 28–Aug. 28, 1957	0.532 ± 0.013	0.532 ± 0.013	5.20
Aug. 30–Sept. 30, 1957	0.244 ± 0.014	0.776 ± 0.019	10.44
Oct. 1957	0.046 ± 0.015	0.822 ± 0.024	
Nov. 1957	Sample not received		
Dec. 1957	Sample not received		
<i>Durban, Union of South Africa</i>			
June 1957	0.080 ± 0.028	0.080 ± 0.028	0.39
July 1957	≤ 0.012	0.092 ± 0.030	0.39
Aug. 1957	0.096 ± 0.026	0.184 ± 0.040	0.78
Sept. 1957	0.230 ± 0.018	0.414 ± 0.044	4.64
Oct. 1957	0.239 ± 0.014	0.653 ± 0.046	3.51
Nov. 1957	0.325 ± 0.018	0.978 ± 0.049	
Dec. 1957	0.219 ± 0.017	1.269 ± 0.052	

Table 3 (Continued)

Collection period	Sr ⁹⁰ /sq mile, mc	Cumulative Sr ⁹⁰ /sq mile, mc	Precipitation, in.
<i>Pretoria, Union of South Africa</i>			
July 1957	0.061 ± 0.004	0.061 ± 0.004	4.29
Aug. 1957	0.074 ± 0.008	0.135 ± 0.009	1.56
Sept. 1957	0.447 ± 0.024	0.582 ± 0.025	4.68
Oct. 1957	0.187 ± 0.015	0.769 ± 0.029	3.12
Nov. 1957	0.104 ± 0.009	0.873 ± 0.031	
Dec. 1957			
<i>Vienna, Austria</i>			
June 1957	0.451 ± 0.031	0.451 ± 0.031	0.78
July 1957			
AEC Roof	1.946 ± 0.092	2.397 ± 0.097	5.07
Meteor. St.	0.216 ± 0.012		
Aug. 1957	0.793 ± 0.050	3.190 ± 0.109	2.73
Sept. 1957	0.593 ± 0.031	3.783 ± 0.113	2.34
Oct. 1957	0.026 ± 0.009	3.809 ± 0.114	0
Nov. 1957	0.218 ± 0.012	4.027 ± 0.114	
Dec. 1957			
<i>Klagenfurt, Austria</i>			
Aug. 1957	1.170 ± 0.050	1.170 ± 0.050	3.51
Sept. 1957	0.473 ± 0.024	1.643 ± 0.055	3.90
Oct. 1957	0.078 ± 0.011	1.721 ± 0.056	1.17
Nov. 1957	0.085 ± 0.026	1.806 ± 0.062	
Dec. 1957			

*Samples were not collected at Karachi from April 1957 through January 1958 due to lack of personnel to handle the operation.

† The sample was not collected at Bangkok at the end of December 1957 since there was no rainfall during this month; personnel at this collecting station have been asked however to collect these samples even during dry periods.

‡ Samples were not collected at Salisbury from May 1957 through October 1957 since there was no rainfall during these months; personnel at this collecting station have been asked however to collect these samples even during dry periods.

Table 4—RAINFALL SAMPLE ANALYSES, PITTSBURGH, PA.

Collection period	Sr ⁹⁰ /sq mile, mc	Cumulative Sr ⁹⁰ /sq mile, mc	Sr ⁹⁰ /liter, dis/min	Sr ⁸⁹ /Sr ⁹⁰ *	Ba ¹⁴⁰ /Sr ⁹⁰ †	Precipitation, in.
1955						
2/25-3/1	0.0536 ± 0.0075	0.0536 ± 0.0075	9.30 ± 1.34			0.51
3/1-3/10	0.0604 ± 0.0024	0.114 ± 0.0078	10.2 ± 0.61			1.85
3/10-3/17	0.0984 ± 0.0058	0.212 ± 0.0098	9.88 ± 0.58			1.32
3/17-4/15	0.0172 ± 0.0039	0.230 ± 0.010	1.10 ± 0.24			1.73
4/15-4/20	0.363 ± 0.029	0.592 ± 0.031	13.1 ± 1.06			0.94
4/20-4/25	0.733 ± 0.037	1.32 ± 0.048	11.4 ± 0.53			2.17
4/25-5/11	0.263 ± 0.012	1.59 ± 0.048	29.6 ± 1.59			0.29
5/11-5/14	0.0550 ± 0.0027	1.64 ± 0.050	3.96 ± 0.18			0.30
5/14-5/23	0.194 ± 0.010	1.84 ± 0.051	24.7 ± 1.35			0.28
5/23-5/24	0.716 ± 0.039	2.55 ± 0.064	48.1 ± 2.64			0.31
5/24-5/26	0.0820 ± 0.0039	2.63 ± 0.064	10.7 ± 0.50			0.44
5/26-5/31	0.223 ± 0.011	2.86 ± 0.065	37.8 ± 1.85			0.20
5/31-6/8	0.410 ± 0.020	3.27 ± 0.068	4.15 ± 0.18			2.72
6/8-6/11	0.0472 ± 0.0019	3.32 ± 0.068	2.69 ± 0.11			0.38
6/11-6/13	0.326 ± 0.017	3.64 ± 0.070	11.1 ± 0.58			0.60
6/13-6/23	0.225 ± 0.022	3.87 ± 0.073	7.77 ± 0.77			0.12
6/23-7/6	0.187 ± 0.0078	4.05 ± 0.074	32.2 ± 1.32			0.34
7/6-7/10	0.346 ± 0.024	4.40 ± 0.078	7.34 ± 0.55			0.28
7/10-7/19	0.0998 ± 0.0097	4.50 ± 0.078	4.38 ± 0.40			0.48
7/19-7/25	0.260 ± 0.020	4.76 ± 0.081	4.97 ± 0.37			0.65
7/25-7/28	0.0876 ± 0.0049	4.85 ± 0.081	2.17 ± 0.13			0.60
7/28-8/6	0.0421 ± 0.0046	4.89 ± 0.081	2.30 ± 0.26			0.18
8/6-8/8	0.0226 ± 0.0023	4.91 ± 0.082	2.85 ± 0.26			0.18
8/8-8/11	0.0662 ± 0.0032	4.98 ± 0.082	1.47 ± 0.08			1.98
8/11-8/16	0.580 ± 0.056	5.56 ± 0.099	8.19 ± 0.79			2.24
8/16-8/23	0.804 ± 0.046	6.36 ± 0.11	21.9 ± 1.32			1.71
8/23-8/31	0.0304 ± 0.0024	6.39 ± 0.11	8.34 ± 0.69			0.66
8/31-9/28	0.104 ± 0.0066	6.50 ± 0.11	2.58 ± 0.16			1.84
9/28-10/10	0.0519 ± 0.0029	6.55 ± 0.11	2.83 ± 0.16			0.76
10/10-10/18	0.134 ± 0.0066	6.68 ± 0.11	3.75 ± 0.16			1.32
10/18-10/20	0.0385 ± 0.0017	6.72 ± 0.11	8.98 ± 0.42			0.09
10/20-10/24	0.0448 ± 0.0022	6.76 ± 0.11	4.25 ± 0.21			0.42
10/24-10/29	0.0626 ± 0.0032	6.83 ± 0.11	13.3 ± 0.66			0.28
10/29-10/31	0.0667 ± 0.0032	6.89 ± 0.11	10.1 ± 0.50			0.40
10/31-11/12	0.0701 ± 0.0034	6.96 ± 0.11	15.9 ± 0.77			0.31
11/12-11/14	0.0221 ± 0.0013	6.99 ± 0.11	5.97 ± 0.37			0.08
11/14-11/21	0.0667 ± 0.0029	7.05 ± 0.11	1.17 ± 0.05			2.25
11/21-12/3	0.0855 ± 0.0056	7.14 ± 0.11	4.49 ± 0.29			0.35
12/3-12/14	0.0185 ± 0.0014	7.16 ± 0.11	84.3 ± 6.34			0.07
12/14-12/24	0.0319 ± 0.0034	7.19 ± 0.11	137 ± 15.9			0.05
12/24-2/3/56	0.618 ± 0.049	7.81 ± 0.12	7.66 ± 0.79			2.63
1956						
2/3-2/13	0.284 ± 0.020	8.06 ± 0.12	4.46 ± 0.34			2.10
2/13-2/27	0.643 ± 0.039	8.70 ± 0.13	8.51 ± 0.50			2.95
2/27-3/6	0.575 ± 0.029	9.27 ± 0.13	13.7 ± 0.79			0.76
3/6-3/24	0.448 ± 0.027	9.72 ± 0.13	7.40 ± 0.53			3.13

Table 4 (Continued)

Collection period	Sr ⁹⁰ /sq mile, mc	Cumulative Sr ⁹⁰ /sq mile, mc	Sr ⁹⁰ /liter, dis/min	Sr ⁸⁹ /Sr ⁹⁰ *	Ba ¹⁴⁰ /Sr ⁹⁰ †	Precipitation, in.
3/24-4/1	0.290 ± 0.022	10.01 ± 0.14	12.4 ± 1.06			1.21
4/1-4/7	0.346 ± 0.017	10.36 ± 0.14	9.25 ± 0.53			1.80
4/7-4/21	0.331 ± 0.020	10.69 ± 0.14	20.3 ± 1.32			0.87
4/21-4/30	0.348 ± 0.029	11.04 ± 0.14	10.8 ± 1.06			1.50
4/30-5/14	0.433 ± 0.024	11.47 ± 0.14	10.3 ± 0.79			2.63
5/14-5/28	0.950 ± 0.049	12.42 ± 0.15	19.6 ± 0.79			2.57
5/28-5/31	0.0735 ± 0.0049	12.49 ± 0.15	10.0 ± 0.79			0.38
5/31-6/4	0.236 ± 0.012	12.73 ± 0.15	17.4 ± 0.79			0.84
6/4-6/15	0.475 ± 0.027	13.20 ± 0.15	15.1 ± 0.79			
6/15-6/18	0.164 ± 0.0073	13.37 ± 0.15	2.81 ± 0.12			2.00
6/18-6/25	0.168 ± 0.0073	13.53 ± 0.15	9.1 ± 0.4			1.18
6/25-7/4	0.321 ± 0.012	13.86 ± 0.15	6.3 ± 0.3			0.47
7/4-7/10	0.129 ± 0.0049	13.98 ± 0.15	5.2 ± 0.2			0.92
7/10-7/17	0.0998 ± 0.0049	14.08 ± 0.15	13.7 ± 0.6			0.50
7/17-7/21	0.0840 ± 0.0032	14.17 ± 0.16	7.0 ± 0.3			0.80
7/21-7/23	0.158 ± 0.0073	14.33 ± 0.16	8.0 ± 0.3			0.82
7/23-7/28	0.183 ± 0.0073	14.51 ± 0.16	6.2 ± 0.3			0.89
7/28-8/6	0.462 ± 0.015	14.97 ± 0.16	5.2 ± 0.2			3.38
8/6-8/13	0.102 ± 0.0049	15.07 ± 0.16	13.2 ± 0.6			0.87
8/13-8/20	0.0436 ± 0.0017	15.12 ± 0.16	15.4 ± 0.6			0.02
8/20-8/28	0.0998 ± 0.0049	15.22 ± 0.16	5.0 ± 0.2			0.79
8/28-9/1	0.0577 ± 0.0027	15.28 ± 0.16	2.46 ± 0.12			0.70
9/1-9/6	0.112 ± 0.0049	15.39 ± 0.16	4.8 ± 0.2			0.54
9/6-9/11	0.0506 ± 0.0022	15.44 ± 0.16	12.2 ± 0.6			0.15
9/11-9/15	0.158 ± 0.0073	15.60 ± 0.16	14.3 ± 0.6			0.40
9/15-9/17	0.102 ± 0.0049	15.70 ± 0.16	12.7 ± 0.6			0.41
9/17-9/22	0.156 ± 0.0073	15.85 ± 0.16	15.3 ± 0.6			0.54
9/22-9/24	0.190 ± 0.0073	16.04 ± 0.16	12.5 ± 0.5			0.39
9/24-10/5	0.0769 ± 0.0036	16.12 ± 0.16	2.84 ± 0.22			0.81
10/5-10/20	0.0706 ± 0.0029	16.19 ± 0.16	20.0 ± 1.2			0.52
10/20-10/23	0.0202 ± 0.0012	16.21 ± 0.16	6.7 ± 0.6			0.12
10/23-10/27	0.0146 ± 0.0010	16.23 ± 0.16	4.6 ± 0.4			0.20
10/27-11/2	0.0472 ± 0.0019	16.27 ± 0.16	6.2 ± 0.4			0.18
11/2-11/12	0.0480 ± 0.0024	16.32 ± 0.16	73 ± 5			0.09
11/12-11/21	0.0419 ± 0.0019	16.36 ± 0.16	4.4 ± 0.3			0.41
11/21-12/3	0.0825 ± 0.0041	16.45 ± 0.16	19.5 ± 1.5			0.24
12/3-12/9	0.0657 ± 0.0029	16.51 ± 0.16	2.39 ± 1.6			1.45
12/9-12/12	0.0319 ± 0.0017	16.54 ± 0.16	11.6 ± 0.9			0.02
12/12-12/16	0.0755 ± 0.0029	16.62 ± 0.16	3.15 ± 0.16			0.72
12/16-12/21	0.0136 ± 0.0019	16.63 ± 0.16	1.47 ± 0.12			0.31
12/21-12/24	0.154 ± 0.0063	16.79 ± 0.16	7.3 ± 0.3			0.53
12/24-12/27	0.101 ± 0.0063	16.89 ± 0.16	6.6 ± 0.4			0.22
12/27-12/30	0.0626 ± 0.0024	16.95 ± 0.16	6.7 ± 0.3			0.30
12/30-1/7/57	0.0314 ± 0.0019	16.98 ± 0.16	4.6 ± 0.3			0.28
1957						
1/7-1/9	0.0696 ± 0.0022	17.05 ± 0.16	9.5 ± 0.4			0.15
1/9-1/15	0.209 ± 0.012	17.26 ± 0.16	57 ± 4			0.09
1/15-1/22	0.0428 ± 0.0019	17.30 ± 0.16	3.1 ± 0.2			0.38
1/22-1/26	0.0789 ± 0.0029	17.38 ± 0.16	17.7 ± 0.7			0.15
1/26-1/29	0.151 ± 0.0073	17.53 ± 0.16	13.0 ± 0.7			0.39
1/29-2/2	0.0752 ± 0.0032	17.61 ± 0.16	10.3 ± 0.4			0.27

Table 4 (Continued)

Collection period	Sr ⁹⁰ /sq mile, mc	Cumulative Sr ⁹⁰ /sq mile, mc	Sr ⁹⁰ /liter, dis/min	Sr ⁸⁹ /Sr ⁹⁰ *	Ba ¹⁴⁰ /Sr ⁹⁰ †	Precipitation, in.
2/2-2/7	0.222 ± 0.012	17.83 ± 0.16	23.4 ± 1.6			0.32
2/7-2/10	0.102 ± 0.0049	17.93 ± 0.16	10.6 ± 0.5			0.26
	0.0954 ± 0.0044		9.9 ± 0.5			
2/10-2/14	0.0871 ± 0.0063	18.02 ± 0.16	29 ± 2			0.17
	0.0930 ± 0.0039		28 ± 1.5			
2/14-2/19	0.158 ± 0.0068	18.17 ± 0.16	162 ± 7			0.03
	0.138 ± 0.0097		151 ± 12			
2/19-2/27	0.204 ± 0.0097	18.38 ± 0.16	16.2 ± 0.8			0.53
	0.219 ± 0.0097		18.0 ± 0.7			
2/27-3/2	0.133 ± 0.0083	18.49 ± 0.16	11.9 ± 0.8			0.41
	0.0901 ± 0.0039		7.5 ± 0.4			
3/2-3/7	0.0711 ± 0.0054	18.57 ± 0.16	12.0 ± 1.0			0.14
	0.0842 ± 0.0058		13.3 ± 1.0			
3/7-3/9	0.0803 ± 0.0039	18.64 ± 0.16	3.8 ± 0.2			0.88
	0.0696 ± 0.0068		2.9 ± 0.3			
3/9-3/19	0.239 ± 0.0097	18.86 ± 0.16	35 ± 2			0.25
	0.200 ± 0.0097		29 ± 1.5			
3/19-3/25	0.140 ± 0.0058	18.99 ± 0.16	41 ± 2			0.08
	0.118 ± 0.0058		35 ± 2			
3/25-3/27	0.149 ± 0.0073	19.15 ± 0.16	5.5 ± 0.3			0.79
	0.166 ± 0.0088		6.1 ± 0.4			
3/27-3/30	0.0720 ± 0.0058	19.22 ± 0.16	21.4 ± 1.9			0.17
	0.0716 ± 0.0039		20.8 ± 1.2			
3/30-4/2	0.112 ± 0.0058	19.33 ± 0.16	3.4 ± 0.2			0.98
	0.106 ± 0.0044		3.3 ± 0.15			
4/2-4/4	0.292 ± 0.020	19.65 ± 0.16	6.9 ± 0.5			1.69
	0.346 ± 0.015		8.2 ± 0.4			
4/4-4/6	0.0759 ± 0.0034	19.72 ± 0.16	14.6 ± 0.7			0.36
	0.0589 ± 0.0054		11.2 ± 1.0			
4/6-4/10	0.219 ± 0.0097	19.93 ± 0.16	17.4 ± 0.8			0.69
	0.200 ± 0.0097		16.0 ± 0.7			
4/10-4/18	0.312 ± 0.015	20.27 ± 0.16	9.8 ± 0.5			1.04
	0.370 ± 0.015		12.0 ± 0.5			
4/18-4/24	0.0672 ± 0.0058	20.33 ± 0.16		6.5 ± 0.3		0.07
	0.0565 ± 0.0039			7.6 ± 0.4		
4/24-4/27	0.0282 ± 0.0019	20.36 ± 0.16		14.1 ± 0.7		0.10
	0.0351 ± 0.0039			13.8 ± 1.3		
4/27-5/6	0.0068 ± 0.0015	20.37 ± 0.16				0.01
	0.0049 ± 0.0024					
5/6-5/12	0.117 ± 0.0058	20.49 ± 0.16				0.86
	0.137 ± 0.0068					
5/12-5/14	0.111 ± 0.0049	20.60 ± 0.16				0.52
	0.108 ± 0.0088					
5/14-5/16	0.0214 ± 0.0049	20.62 ± 0.16	15 ± 4			0.31
	0.0224 ± 0.0024		15.4 ± 1.6			
5/16-5/19	0.0331 ± 0.0063	20.66 ± 0.16	26 ± 5			0.05
	0.0365 ± 0.0058		28 ± 5			
5/19-5/20	0.151 ± 0.0073	20.81 ± 0.16	7.9 ± 0.4			0.68
	0.145 ± 0.0063		8.2 ± 0.4			
5/20-5/22	0.0448 ± 0.0034	20.86 ± 0.16	27.6 ± 2.4			0.08
	0.0536 ± 0.0024		21.4 ± 1.2			
5/22-5/23	0.0214 ± 0.0019	20.88 ± 0.16	8.2 ± 0.8			0.03
	0.0248 ± 0.0019		9.7 ± 0.9			

Table 4 (Continued)

Collection period	Sr ⁹⁰ /sq mile, mc	Cumulative Sr ⁹⁰ /sq mile, mc	Sr ⁹⁰ /liter, dis/min	Sr ⁸⁹ /Sr ⁹⁰ * Ba ¹⁴⁰ /Sr ⁹⁰ †	Precipitation, in.
5/23-5/26	0.0195 ± 0.0024 0.0224 ± 0.0019	20.90 ± 0.16	3.3 ± 0.4 3.7 ± 0.4		0.22
5/26-5/27	0.0326 ± 0.0039 0.0312 ± 0.0019	20.93 ± 0.16	5.7 ± 0.7 5.7 ± 0.3		Trace
5/27-6/3	0.0126 ± 0.0019 0.0224 ± 0.0024	20.95 ± 0.16	2.9 ± 0.5 5.0 ± 0.6		
6/3-6/5	0.0482 ± 0.0039 0.0496 ± 0.0024	21.00 ± 0.16	37 ± 3 41 ± 2		
6/5-6/9	0.136 ± 0.0058 0.166 ± 0.0068	21.15 ± 0.16	3.6 ± 0.2 4.4 ± 0.2		1.06
6/9-6/11	0.0336 ± 0.0068 0.0331 ± 0.0039	21.18 ± 0.16	6.7 ± 1.4 6.5 ± 0.8		0.18
6/11-6/12	0.0633 ± 0.0068 0.106 ± 0.0058	21.27 ± 0.16	6.2 ± 0.6 10.5 ± 0.7		0.74
6/12-6/13	0.100 ± 0.0039 0.0964 ± 0.0039	21.37 ± 0.16	6.1 ± 0.3 6.2 ± 0.3		0.48
6/13-6/15	0.0131 ± 0.0019 0.0078 ± 0.0029	21.38 ± 0.16	24 ± 4 15 ± 6		Trace
6/15-6/19	0.0891 ± 0.012 0.0769 ± 0.0034	21.46 ± 0.16	13.1 ± 1.8 12.1 ± 0.6		0.27
6/19-6/24	0.0516 ± 0.0039 0.0414 ± 0.0024	21.51 ± 0.16	14.3 ± 1.1 11.9 ± 0.6		0.26
6/24-6/29	0.0730 ± 0.0054 0.0920 ± 0.0049	21.59 ± 0.16	3.9 ± 0.3 4.9 ± 0.3		0.91
6/29-6/30	0.0706 ± 0.0034 0.0832 ± 0.0044	21.66 ± 0.16	9.8 ± 0.5 11.9 ± 0.7		0.40
6/30-7/1	0.142 ± 0.0058 0.153 ± 0.0058	21.81 ± 0.16	20.9 ± 0.8 18.7 ± 0.8		0.62
7/1-7/5	0.0506 ± 0.0049 0.0608 ± 0.0034	21.87 ± 0.16			0.10
7/5-7/7	0.180 ± 0.009 0.071 ± 0.004	22.00 ± 0.16	9.7 ± 0.5 4.3 ± 0.2		0.99
7/7-7/8	0.102 ± 0.005 0.098 ± 0.005	22.10 ± 0.16	23.0 ± 1.6 23.7 ± 1.7		0.21
7/8-7/9	0.123 ± 0.006 0.192 ± 0.012	22.28 ± 0.16	3.3 ± 0.2 5.0 ± 0.3		1.95
7/9-7/14	0.053 ± 0.005 0.042 ± 0.003	22.34 ± 0.16			0.04
7/14-7/22	0.009 ± 0.005 0.016 ± 0.003	22.35 ± 0.16			Dry
7/22-7/23	0.061 ± 0.006 0.034 ± 0.002	22.41 ± 0.16	5.4 ± 0.6 2.9 ± 0.2		0.50
7/23-7/28	0.044 ± 0.004 0.044 ± 0.002	22.45 ± 0.16			0.20
7/28-7/29	0.123 ± 0.005 0.108 ± 0.004	22.57 ± 0.16	15.4 ± 0.8 13.5 ± 0.7		0.52
7/29-8/5	0.013 ± 0.003 0.012 ± 0.004	22.58 ± 0.16			Trace
8/5-8/10	0.024 ± 0.003 0.027 ± 0.003	22.61 ± 0.16	8.8 ± 1.1 9.8 ± 1.0		0.013

Table 4 (Continued)

Collection period	Sr ⁹⁰ /sq mile, mc	Cumulative Sr ⁹⁰ /sq mile, mc	Sr ⁹⁰ /liter, dis/min	Sr ⁸⁹ /Sr ⁹⁰ *	Ba ¹⁴⁰ /Sr ⁹⁰ †	Precipitation, in.
8/10-8/18	0.002 ± 0.002 0.003 ± 0.003	22.61 ± 0.16				Dry
8/18-8/20	0.024 ± 0.004 0.024 ± 0.003	22.64 ± 0.16				0.07
8/20-8/26	0.009 ± 0.003 0.005 ± 0.005	22.64 ± 0.16				Trace
8/26-8/31	0.022 ± 0.004 0.028 ± 0.003	22.67 ± 0.16	13.3 ± 2.2 18.3 ± 1.7			0.13
8/31-9/3	0.024 ± 0.006 0.034 ± 0.007	22.70 ± 0.16	10.0 ± 2.5 13.2 ± 2.6	66 47	150 110	0.28
9/3-9/10	0.019 ± 0.006 0.018 ± 0.009	22.71 ± 0.16	3.1 ± 0.9 2.8 ± 1.4	68 69	4.7 53	0.26
9/10-9/14	0.005 ± 0.005 0.005 ± 0.005	22.72 ± 0.16	≤ 1.5 ≤ 1.5			0.15
9/14-9/16	0.039 ± 0.004 0.034 ± 0.008	22.76 ± 0.16	2.7 ± 0.3 2.3 ± 0.6	58 58	100 110	0.66
9/16-9/21	0.022 ± 0.008 0.024 ± 0.010	22.78 ± 0.16	0.59 ± 0.21 0.55 ± 0.24	43 36	12	1.82
9/21-9/23	0.018 ± 0.005 0.032 ± 0.006	22.80 ± 0.16	0.59 ± 0.14 0.88 ± 0.17	76 52	24 34	1.73
9/23-10/1	0.010 ± 0.008 0.005 ± 0.005	22.81 ± 0.16		56	81	Dry
10/1-10/7	0.070 ± 0.012 0.068 ± 0.009	22.88 ± 0.16	9.5 ± 1.6 9.2 ± 1.3	94 116	1.6 2.4	0.27
10/7-10/17	0.03 ± 0.03 0.04 ± 0.04	22.92 ± 0.16	≤ 5 ≤ 7			0.28
10/17-10/18	0.023 ± 0.004 0.016 ± 0.004	22.94 ± 0.17	3.4 ± 0.6 2.5 ± 0.6	24 32	33 59	0.32
10/18-10/19	0.004 ± 0.004 0.004 ± 0.004	22.94 ± 0.17	≤ 7 ≤ 6			0.04
10/19-10/24	0.062 ± 0.009 0.048 ± 0.005	22.99 ± 0.17	3.2 ± 0.5 2.4 ± 0.3	23 18		0.91
10/24-10/27	0.033 ± 0.005 0.017 ± 0.002	23.02 ± 0.17	14.0 ± 2.2 8.0 ± 1.1		4.0 12	0.12
10/27-11/1	0.008 ± 0.002 0.011 ± 0.004	23.03 ± 0.17		24 17	3.2	Dry
11/1-11/3	0.005 ± 0.002 0.006 ± 0.003	23.04 ± 0.17		19 15	2.5	Dry
11/3-11/5	0.019 ± 0.002 0.033 ± 0.004	23.06 ± 0.17	2.6 ± 0.3 4.6 ± 0.5	19 14	2.6	0.29
11/5-11/8	0.032 ± 0.002 0.029 ± 0.005	23.09 ± 0.17	4.9 ± 0.3 4.4 ± 0.8	14 15	7.8 10	0.29
11/8-11/13	0.022 ± 0.003 0.026 ± 0.003	23.12 ± 0.17	3.2 ± 0.4 4.1 ± 0.4	21 15		0.20
11/13-11/18	0.031 ± 0.004 0.036 ± 0.003	23.15 ± 0.17	3.1 ± 0.4 3.4 ± 0.3	16 16	2.0 1.1	0.57
11/18-11/19	0.033 ± 0.003 Lost	23.18 ± 0.17	1.8 ± 0.15	16	7.3	0.69
11/19-11/26	0.020 ± 0.002 0.034 ± 0.002	23.21 ± 0.17		12 9.1	2.1 4.3	Dry

Table 4 (Continued)

Collection period	Sr ⁹⁰ /sq mile, mc	Cumulative Sr ⁹⁰ /sq mile, mc	Sr ⁹⁰ /liter, dis/min	Sr ⁸⁹ /Sr ⁹⁰ *	Ba ¹⁴⁰ /Sr ⁹⁰ †	Precipitation, in.
11/26-12/1	0.024 ± 0.003	23.23 ± 0.17	11.9 ± 1.8	15	4.5	0.13
	0.019 ± 0.002		9.5 ± 1.0	14		
12/1-12/4	0.058 ± 0.003	23.29 ± 0.17	6.4 ± 0.5	12	5.1	0.26
	0.054 ± 0.005		6.3 ± 0.6	11	3.1	
12/4-12/8	0.135 ± 0.012	23.44 ± 0.17	4.3 ± 0.4	19		1.11
	0.129 ± 0.007		4.3 ± 0.2	22		
12/8-12/9	0.029 ± 0.002	23.49 ± 0.17	10.7 ± 0.8	16	5.4	0.11
	0.025 ± 0.002		9.2 ± 0.6	18	5.2	
12/9-12/13	0.007 ± 0.002	23.50 ± 0.17		12	3.8	
	0.008 ± 0.004			12	6.4	
12/13-12/16	0.042 ± 0.005	23.54 ± 0.17		6.7	9.5	0.04
	0.038 ± 0.003			9.0	3.6	
12/16-12/18	0.049 ± 0.003	23.59 ± 0.17	2.85 ± 0.20	28	33	0.61
	0.042 ± 0.003		2.45 ± 0.20	36	32	
12/18-12/19	0.029 ± 0.003	23.62 ± 0.17	9.5 ± 1.0	20	9.8	0.15
	0.035 ± 0.004		10.9 ± 1.1	21	6.8	
12/19-12/21	0.131 ± 0.010	23.74 ± 0.17	4.1 ± 0.3	17	5.6	1.22
	0.115 ± 0.006		3.5 ± 0.2	19	3.7	
12/21-12/26	0.073 ± 0.004	23.82 ± 0.17	2.27 ± 0.15	17	0.2	1.30
	0.077 ± 0.004		2.35 ± 0.15	16		
12/26-12/29	0.012 ± 0.003	23.83 ± 0.17		52	3.0	Trace
	0.014 ± 0.004			11	1.8	

* Sr⁸⁹ value extrapolated to end of sampling period.

† Ba¹⁴⁰ value extrapolated to end of sampling period.

Table 5—RAINFALL SAMPLE ANALYSES, CHICAGO, ILL.

Collection Period	Sr ⁹⁰ /sq mile, mc	Cumulative Sr ⁹⁰ /sq mile, mc	Sr ⁹⁰ /liter, dis/min	Precipitation, in.
1957				
6/10-6/24	0.367 ± 0.012	4.504 ± 0.063	35 ± 2	1.94
6/24-7/8	0.291 ± 0.015	4.795 ± 0.065	61 ± 3	1.63
7/8-7/22	1.20 ± 0.07	5.995 ± 0.096	18.3 ± 1.0	5.62
7/22-8/5	0.320 ± 0.036	6.315 ± 0.102	4.2 ± 0.5	3.95
8/5-8/19	0.235 ± 0.012	6.550 ± 0.102	5.8 ± 0.3	2.60
8/19-9/3	0.130 ± 0.007	6.680 ± 0.102	12.5 ± 0.6	1.15
9/3-9/16	0.054 ± 0.004	6.734 ± 0.103	7.5 ± 0.5	0.53
9/16-9/30	Sample lost			
9/30-10/15	0.016 ± 0.002	6.758 ± 0.110		
10/15-10/28	0.69*	7.446 ± 0.110	3.4 ± 0.2	
10/28-11/11	≤ 0.0025†			
11/11-11/25	0.70*	8.146 ± 0.110	5.8 ± 3.0	
11/25-12/9	0.047 ± 0.003	8.193 ± 0.110		
12/9-12/23	0.144 ± 0.009	8.337 ± 0.110	9.5 ± 0.6	
12/23-1/6/58	0.56*	8.897 ± 0.110	20.2 ± 1.2	

* Calculated from measured specific activity and total volume of sample collected.

† Winds upset collector Nov. 8, 1957; sample consists of residue only in distilled water.

Table 6—MILLICURIES OF Sr⁹⁰ PER SQUARE MILE IN U. S. SOIL SAMPLES
COLLECTED DURING OCTOBER 1955, 1956, AND 1957

Site	Depth, in.	Sr ⁹⁰ /sq mile, mc			Rainfall 1956, in.
		1955*	1956†	1957†	
Albuquerque‡	0-2	(3.4); (3.6)	6.5, 6.2	9.2, 9.0	3.97
	2-6			11.8, 11.1	
	2-10½		3.8, 2.1		
	Total	5.1	9.3	20.5	
Atlanta	0-2	6.6	12.6, 14.4	14.5, 15.2	43.88
	2-6		2.4, 2.8	5.6, 5.0	
	Total	7.9	16.1	20.2	
Binghamton	0-2	8.9	13.0, 13.8	18.8, 18.7	48.90
	2-6		3.4, 4.3	4.0, 3.9	
	Total	11.4	17.3	22.8	
Boise	0-2	14.0	19.0, 21.9	19.8, 19.2	12.71
	2-6		2.6, 3.4	2.7, 2.7	
	Total	16.2	23.4	22.2	
Des Moines	0-2	6.8	21.1, 21.0	17.9, 18.6	14.23
	2-6		7.4, 6.5	6.9, 5.1	
	Total	8.9	28.0	24.2	
Detroit	0-2	8.0	16.1, 16.2	15.0, 16.2	34.92
	2-6		5.4, 6.2	14.2, 14.4	
	Total	11.1	21.9	29.9	
Grand Junction§	0-2	3.5	7.8, 7.1	19.9, 19.4	3.76
	2-6			3.7, 4.4	
	2-10½		≤0.5, ≤0.5		
	Total	3.8	7.5	23.7	
Jacksonville	0-2	5.9	5.8	17.5, 15.3	44.69
	2-6		2.2, 3.3	8.8, 9.4	
	Total	8.7	8.6	25.5	
Los Angeles	0-2	1.5	6.6, 7.7	6.9, 6.5	13.50
	2-6		3.3, 2.2	1.9, 1.2	
	Total	2.1	9.9	8.3	
Memphis	0-2	11.0	14.3, 14.3	23.4, 22.7	43.07
	2-6		6.4, 6.6	15.8, 14.1	
	Total	15.8	20.8	38.0	
New Orleans	0-2	5.9	8.6, 8.1	15.3, 15.8	52.62
	2-6		3.3, 2.2	15.6, 14.0	
	Total	7.8	11.1	30.4	
New York¶	0-2	(4.6); (6.9)	9.3, 13.0	(20.0, 19.5) (17.7, 18.5)	41.26
	2-6		13.0, 13.0	(7.6) (6.8, 7.6)	
	6-12			(6.7, 5.9) (9.4, 8.4)	
	Total	12.6	24.1	33.7 34.2	
Philadelphia	0-2	5.6	10.0, 9.2	19.2, 19.8	39.06
	2-6		6.1, 5.3	3.3, 3.0	
	Total	8.8	15.4	22.7	

Table 6—(Continued)

Site	Depth, in.	Sr ⁹⁰ /sq mile, mc			Rainfall 1956, in.
		1955*	1956†	1957‡	
Rapid City	0-2	13.0	18.4, 21.1	27.7, 28.3	13.86
	2-6		11.4, 9.5	4.1, 3.4	
	Total	19.5	30.3	31.7	
Rochester	0-2	6.9	15.6	22.1, 19.7	41.33
	2-6		2.4, 2.4	7.3, 6.6	
	Total	8.0	18.0	27.9	
Salt Lake City	0-2	11.0	18.0, 18.8	19.1, 19.7	12.53
	2-6		18.0	0.8, 0.4	
	2-8		5.7, 5.9		
	Total	13.9	24.1	20.0	
Seattle	0-2	5.0	13.0, 12.3	21.8, 21.3	43.70
	2-6		6.7, 6.8	5.5, 6.4	
	Total	7.8	19.3	27.5	

* Soils representing 2 to 6 in. in depth not analyzed. Value for 0 to 6 in. calculated by assuming the same ratio of Sr⁹⁰ as was in the two depths for 1956. Single analyses only.

† Duplicate analyses performed per sample.

‡ Two sampling sites ~15 ft. apart in 1955 and two sampling sites ~50 ft. apart in 1956.

§ Results for 1956 may be low by a factor of 2.

¶ Two sampling sites ~15 ft. apart in 1955 and three sampling sites ~15 ft. apart in 1957.

Table 7—GEOGRAPHICAL DISTRIBUTION OF Sr⁹⁰ IN SOIL, 1955*

Location	Sr ⁹⁰ , dis/min/cu ft
Lamont Laboratory	164
Haledon, N. J.	174
Rochelle Park, N. J.	151
Clifton, N. J.	66
Catskill, N. Y.	66
Van Cortlandt Park	200
Speculator, N. Y.	279
Demarest, N. J.	176
Ridgefield Park, N. J.	220
Westwood, N. J.	67

* Soil samples were taken from 0- to 2-in. depths, HCl leach.

Table 8—DEPTH DISTRIBUTION OF Sr⁹⁰ IN SOIL

Location	Sr ⁹⁰ , dis/min/sq ft		
	0 to 2 in.	2 to 6 in.	6 to 12 in.
Rockland County, N. Y.	116	14	
	82	43	
	60	104	
Lamont	267	52	
	116		<6
Rochelle Park, N. J.	151	8	
Haledon, N. J.*	174	59	
Clifton, N. J.*	66	49	
Catskill, N. Y.	128	20	24†
Speculator, N. Y.	279	110	
Demarest, N. J.	176	<6	
Ridgefield Park, N. J.	220	80	
Westwood, N. J.	67	27 (sand)	
Queens, N. Y.*	191	39	
Idlewild Airport	50	52 (sand)	

* May not be exact pairs.

† 6 to 10 in.

Table 9—Sr⁹⁰ IN SOIL COLLECTED OUTSIDE THE UNITED STATES

Site	Location	Sampling date	Depth from surface, in.	Available Ca, g/sq ft	Sr ⁹⁰ /sq mile, mc
Asia and Near East, 1954					
Beka Valley, Lebanon		2/25	3	42.73	2.41
		2/25	6	62.49	1.2
Australia and New Zealand, 1955					
Sydney, Australia	American Consul General's Residence	2/15	4	7.64	1.31
Perth, Australia	Henley Park (Soil B)	2/15	4	10.0	1.58
Wellington, N. Z.		2/13	4	23.08	2.48
		2/13	4	24.63	1.06
Africa, 1955					
Algiers, Algeria	Villa Mustapha Rais	2/15	4	60	2.0
	Villa Montfeld	2/15	4	53.8	4.4
Dakar, F. W. A.	No. 1 Border Swamp	2/13	4	4.4	0.45
	No. 2 Bleaker Stretch	2/14	4	1.3	0.34
Leopoldville, B. C.	No. 1 Residence suburb	March	4	1.02	0.49
	No. 2 Industrial Area	March	4	40.82	0.76
Durban, Natal	Adams College	2/15	4	12.6	1.6
Asia and Near East, 1955					
Tokyo, Japan	Residence of Marine Guard	2/10	4	20.26	5.64
	Residence of C. Sedgwick	2/10	4	18.9	6.49
Aden, Saudi Arabia		February	4	151	4.34
		February	4	93.9	1.83
Damascus, Syria	Ambassador's yard	2/11	4	62.8	2.5
Bierut, Lebanon	Embassy	2/10	4	52.6	6.5
Terbol, Lebanon		2/10	4	46.7	2.4
Ankara, Turkey		2/7	4	106	4.0
	Kohler yard	2/7	4		2.51
Karachi, Pakistan	22 miles from Karachi	2/7	4	37.60	0.30
	25 miles from Karachi	2/7	4	64.71	0.25
Bombay, India		2/14	4	205	3.0
		2/14	4	301	5.5
New Delhi, India	2 miles before Kutab Minor	2/14	4	70.84	3.60
	2 miles after Kutab Minor	2/14	4	63.05	2.06
Europe, 1955					
East Suffolk, England	Brook Meadow—Earl Soham	March	4	60.28	2.3
	Cemetery Field—And. Hall Farm	March	4	57.81	1.8
	Park Field—Water Meadow	March	4	43.97	3.4
	White House Farm—Earl Soham	March	4	86.26	1.3
	White House Farm—Earl Soham	March	4	61.24	2.4
Wales, England	Gas Ffynnon Vyrnwy Mont.	March	4	14.83	7.5

Table 9 (Continued)

Site	Location	Sampling date	Depth from surface, in.	Available Ca, g/sq ft	Sr ⁹⁰ /sq mile, mc
Wales, England	Werglodd Ganol Lake	March	4	17.37	6.5
	Vyrnwy				
	Tyllwyd Cwmystwyth Card.	March	4	1.23	6.0
	Lluest Rd.—Tyllwyd Cwm., Card.	March	4	0.63	7.3
	Ffostil Talgarth, Brecon	March	4	22.62	5.2
Paris, France	American Embassy	2/16	4	66.2	1.3
Australia and New Zealand, 1956					
Sydney, Australia	Campbell Residence	4/16	6	14.60	5.64
Melbourne, Australia	Weidermeyer Yard	4/18	6	27.07	2.96
Brisbane, Australia		5/8	6	38.21	3.26
Adelaide, Australia		5/7	6	29.35	5.1
Perth, Australia		May	6	7.45	2.57
Alice Springs, Australia		6/19	6	13.43	1.86
Copping Township, Tasmania		5/6	6	24.30	1.33
N. Auckland, New Zealand	Near Whangarei	5/10	6	26.79	3.81
Wellington, New Zealand	W. H. Lee Farm	4/24	6	15.88	3.29
South Canterbury, New Zealand	D. Talbot	4/27	6	26.64	2.18
Pacific, 1956					
Canton Island	4.4 miles NE of CAA Beacon	4/27	7	32.39	3.46
Wake Island	Japanese Garden area	4/2	6	78.51	8.62
Oahu, Hawaii	Opposite Wheeler Field	11/23	6	50.92	7.85
	Kaneohe's Girl School	11/23	6	22.78	7.60
	Kahuku Golf Course	11/23	6	77.73	0.90
Africa, 1956					
Dakar, F. W. A.	4.2 km west of Grand Hotel de N'Gor	9/10	6	33.60	2.34
Leopoldville, B. C.	Parc Hembise (Site 1)	9/11	6	3.32	1.28
	150 Blvd. Albert	9/12	6	3.88	3.62
Durban, U. of S. A.	Consul General	9/14	6	14.19	4.66
	Adams College	9/14	6	15.72	3.16
Salisbury, S. R.	Experimental Station	9/17	6	29.63	2.64
Kikuyu, Kenya	Forestry Research Program	9/27	6	41.62	2.82
Asia and Near East, 1956					
Tokyo, Japan	Embassy Yard	4/4	6	18.61	1.95
	Morgan Yard	4/4	6	26.46	1.60
Hiroshima, Japan	ABCC Yard	4/5	6	18.75	5.52
	3400-M-N Bamboo	4/6	7	1.30	6.38
Nagasaki, Japan	Kite Hill	May	4	2.91	3.84

Table 9 (Continued)

Site	Location	Sampling date	Depth from surface, in.	Available Ca, g/sq ft	Sr ⁹⁰ /sq mile, mc
Manila, P. I.	McKinley Cemetery	4/9	6	60.27	4.68
	Clark Field	4/9	6	12.44	3.86
	Navy Transmitter St.	4/9	6	19.80	8.95
Singapore, Malaya	Consul General's Residence	4/13	6	3.46	2.6
	Leedon Park	4/15	6	1.95	3.17
Damascus, Syria	Ambassador's Yard	10/2	6	82.74	4.96
Bierut, Lebanon	U. S. Embassy Yard	10/1	6	63.30	16.17
Ankara, Turkey	Kohler Yard	10/4	6	69.56	10.25
Europe, 1956					
Oslo, Norway	7 Voll Terrasse	8/26	6	9.49	11.6
Lake Fense, Norway	Experimental Farm	9/2	6	2.77	11.9
Paris, France	C-Bldg.	9/4	6	78.52	7.24
Rome, Italy	Embassy Yard	10/5	6	120.95	27.72
Alaska, 1956					
Palmer	Matanuska Experimental Stat.	8/6	6	25.99	5.89
Pt. Barrow	3 miles S. of A.F. field	8/10	4 ¹ / ₂	11.36	2.18
	2 miles E. of A.F. field	8/10	4 ¹ / ₂	11.34	2.94
Fairbanks	Experimental Station	8/8	6	30.40	4.23
Latin America, 1956					
Panama Canal Zone	Fort Amador	1/3	6	88.94	4.9
	Fort Clayton	1/3	6	33.38	5.97
Antofogasta, Chile	Near airport	1/13	1 ¹ / ₂	5.2	0.06
Santiago, Chile	Lo Aguirre Anaconda Ranch	1/16	6	77.58	1.95
Punta Arenas, Chile	100 km. north	1/23	6	26.27	1.28
Sao Paulo, Brazil	Mr. Clarence Roberts Residence	1/30	6	21.1	2.6
Belem, Brazil	1 ¹ / ₂ km. NE of airport	1/31	6	4.79	2.55
	American Consulate	1/31	6	4.92	4.07
Asuncion, Paraguay	American Golf Club	January	6	6.10	1.9
Buenos Aires, Argentina	Ambassador's Yard	1/18	6	53.29	2.62
Bogota, Columbia	Ambassador's Yard	1/6	6	31.38	2.53
Caracas, Venezuela	Ambassador's Res.	2/2	6	46.31	2.55
Lima, Peru	Ambassador's Res.	1/9	6	63.9	3.82
Huancayo, Peru	Geophysics Institute	2/9	6	51.31	1.95

Table 9 (Continued)

Site	Location	Sampling date	Depth from surface, in.	Available Ca, g/sq ft	Sr ⁹⁰ /sq mile, mc
Canada, 1956					
Ottawa, Ont.	Central Experimental Farm	5/14	6	22.80	9.91
Agassiz, B. C.	Experimental Farm Area	August	6	4.57	2.51
Lacombe, Alb.	Experimental Farm Area	August	6	52.0	8.49
Saanichten, B. C.	Experimental Station	August	6	42.51	14.98
Eureka, N.W.T.	Ellesmere Island	9/12	6	13.72	2.88
Resolute Bay, N.W.T.	Cornwallis Island	8/12	6	17.90	1.07
	Cornwallis Island	8/12	6	22.78	0.65
Fort Simpson, N.W.T.	Experimental Farm Area	8/11	6	142.41	2.65
Sable Island	Near residential area	August	6	0.65	3.68
	Near residential area	August	6	3.89	12.0
St. John's, Nfld.	Experimental Farm Area	10/3	6	8.94	9.09
Aklavik, N.W.T.	Experimental Farm Area	8/15	6	16.28	2.27
Europe, 1957					
Bergen, Norway	Nygards Park	2/25	6	18.57	35.2
Naples, Italy	Lago Patria	10/27	6		27.3
Pacific, 1957					
Oahu, Hawaii	Kawailoa Girls School	November	6		24.9
	Leilehua Golf Course	November	6		30.2

Table 10—CUMULATIVE Sr⁹⁰ DEPOSITION (MILLICURIES PER SQUARE MILE) ESTIMATED FROM GUMMED FILM MEASUREMENTS FOR CONTINENTAL UNITED STATES

	Sept. 1955	June 1956	June 1957		Sept. 1955	June 1956	June 1957
Albuquerque, N. Mex.	20	34.9	45	Medford, Oreg.		8.9	13
Atlanta, Ga.	3.8	11.0	20	Memphis, Tenn.	8.4	15.7	24
Billings, Mont.	5.7	14.9	26	Miami, Fla.		12.1	16
Binghamton, N. Y.	2.2	8.9	13	Minneapolis, Minn.	4.9	16.4	25
Boise, Idaho	9.2	18.5	27	New Haven, Conn.	3.6	12.0	20
Boston, Mass.		13.8	20	New Orleans, La.	5.7	13.6	28
Cape Hatteras, N. C.		9.4	14	New York, N. Y.	4.2	16.7	28
Chicago, Ill.	5.3	14.5	22	Philadelphia, Pa.	4.6	12.7	19
Cleveland, Ohio		15.9	25	Pittsburgh, Pa.	4.1	18.0	26
Concord, N. H.		8.0	11	Rapid City, S. Dak.	6.1	11.6	18
Corpus Christi, Texas		6.3	12	Rochester, N. Y.	3.7	12.9	19
Dallas, Texas	6.1	12.9	25	St. Louis, Mo.	6.0	18.9	
Des Moines, Iowa	6.2	15.5	27	Salt Lake City, Utah	23	34.6	54
Detroit, Mich.	4.2	16	22	San Francisco, Calif.	2.1	8.9	14
Grand Junction, Colo.	18	27.7	39	Scottsbluff, Nebr.	6.3	12.7	38
Jacksonville, Fla.	3.3	7.9	13	Seattle, Wash.	3.5	13.4	19
Knoxville, Tenn.		10.5	18	Tucson, Ariz.		15.2	25
Las Vegas, Nev.		17.8	23	Washington, D. C.	3.0	12.0	18
Los Angeles, Calif.		6.8	11	Wichita, Kans.		14.7	25
Louisville, Ky.		14.1	24				

Table 11—CUMULATIVE Sr⁹⁰ DEPOSITION (MILLCURIES PER SQUARE MILE)
ESTIMATED FROM GUMMED FILM MEASUREMENTS OUTSIDE
CONTINENTAL UNITED STATES

	Sept. 1955	June 1956	June 1957		Sept. 1955	June 1956	June 1957
ALASKA				ITALY			
Anchorage	2.7	8.7	12	Milan			13
Fairbanks		11.8	15	JAPAN			
Juneau		8.4	16	Hiroshima	3.2	13.1	19
Nome		5.7	9	Misawa	2.8	13.9	20
ARGENTINA				Nagasaki	4.9	14.8	21
Buenos Aires	2.8	5.6	9	Tokyo	3.8	12.7	23
AUSTRALIA				LEBANON			
Melbourne	2.1	6.0		Beirut	3.3	18.5	
Sydney	3.5	5.2	6	LIBERIA			
BELGIAN CONGO				Monrovia		7.1	10
Leopoldville	3.4	5.5		LIBYA			
BERMUDA	4.6	13.9	21	Tripoli	4.0	15.9	24
BOLIVIA				MALAYA			
La Paz	4.2	6.2	9	Singapore	4.6	6.1	7
BRAZIL				MEXICO			
Belem	3.4	5.8		Mexico City	5.1	11.6	16
Sao Paulo	2.7	5.0		MOROCCO			
CANADA				Sidi Slimane	2.5	14.5	18
Churchill, Manitoba	1.9	3.9	6	NEW ZEALAND			
Edmonton, Alberta	2.8	12.2	18	Wellington	2.1	3.6	5
Goose Bay, Labrador	4.0	8.6	13	NIGERIA			
Moncton, New Brunswick	3.7	9.8	13	Lagos	1.9	4.1	8
Montreal, Quebec	4.0	11.0	16	NORWAY			
Moosonee, Ontario	2.8	9.0	13	Oslo	2.5	7.9	13
North Bay, Ontario	3.1	10.8	17	PACIFIC ISLANDS			
Ottawa, Ontario	3.4	8.7	12	Yap, Caroline Islands	9.0	14.6	17
Regina, Saskatchewan	3.0	9.5	13	Guam, Caroline Islands	8.5	15.8	78
Seven Islands, Quebec	3.3	7.8	12	Truk, Caroline Islands	9.2	14.0	33
Stephenville,				Ponape, Caroline			
Newfoundland	4.3	13.5	20	Islands	14	18.2	41
Winnipeg, Manitoba	3.6	11.4	23	Canton Island	4.2	6.0	7
CEYLON				Iwo Jima	24	30.5	36
Colombo	4.7	6.5	9	Johnston Island	5.9	16.1	30
COLOMBIA				Koror, Palau Island		11.1	14
Bogota	2.6	6.3		Manila, Philippine			
COSTA RICA				Islands	6.6	11.1	17
San Jose	3.2	4.8	7	Midway		12.1	19
ECUADOR				Noumea, New Caledonia	3.2	6.8	8
Quito	2.6	3.6	5	Wake Island	3.6	10.1	22
ETHIOPIA				PANAMA CANAL ZONE	4.1	6.4	9
Addis Ababa	4.2	7.1	11	PERU			
FRENCH WEST AFRICA				Lima	1.8	3.6	
Dakar	3.6	6.2	12	PUERTO RICO			
GERMANY				San Juan	3.9	12.1	15
Rhein Main	3.5	9.4	15	SAUDI ARABIA			
GREENLAND				Dhahran	3.1	7.3	15
Thule	2.0	5.8	9	SCOTLAND			
HAWAII				Prestwick	3.8	11.2	18
French Frigate Shoals		13.6	21	TAIWAN			
Lihue		10.0	18	Taipei	4.6	18.3	
Hilo		19.7	30	THAILAND			
Honolulu	3.5	13.0	16	Bangkok		8.3	10
ICELAND				UNION OF SOUTH AFRICA			
Keflavik	2.9	9.3	21	Durban	1.9	2.4	4
				Pretoria	2.0	4.2	10

2. AIR

Measurements of airborne Sr^{90} and other isotopes serve one of two purposes, depending on whether the samples are taken at ground level or in the upper atmosphere. Surface air concentrations do show the presence of radioactivity and, as such, have been useful in meteorological studies. On the other hand they cannot be readily related to deposition since the actual deposition process is a complex function of local meteorology and particle characteristics. Upper air collections, particularly in the stratosphere, can be used for the prediction of future deposition and in material balance studies.

It must be emphasized that none of the air concentrations found are at an activity level that would in themselves be a direct hazard in inhalation. Hence the measurements are designed purely for obtaining information relating to trajectories and the prediction of future fallout.

2.1 SURFACE AIR

a. *Naval Research Laboratory Collections.* Samples of airborne dust at the surface are collected by the Naval Research Laboratory (NRL). These samples are measured for total fission product activity and in some cases for natural radioactivity. A large number of these samples were made available to Dr. E. A. Martell at the University of Chicago laboratories, where they were analyzed for Sr^{90} . These data are reported in Table 12.

The NRL has instituted a program of radiochemical analysis on later samples. These data are not yet available. Their current network lists the following stations:

Punta Arenas, Chile	Bogota, Colombia
Puerto Montt, Chile	Miraflores, Colombia
Santiago, Chile	San Juan, Puerto Rico
Porto Alegre, Brazil	Miami, Florida
Antofagasta, Chile	Columbia, South Carolina
Chacaltaya, Bolivia	Washington, D. C.
Huancayo, Peru	Bedford, Massachusetts
Lima, Peru	Moosonee, Ontario
Iquitos, Peru	Coral Harbour, N.W. Terr.
Guayaquil, Ecuador	Thule, Greenland
Quito, Ecuador	

b. *U. S. Public Health Service Collections.* The U. S. Public Health Service (USPHS) has been collecting samples of airborne dust during the test series for the past two years. These samples are measured in the field for total beta activity, but no radiochemical work has been done on these samples as yet. The activity collected on a 24-hr sample at the relatively low flow rates used is not sufficient for radiochemical determination of Sr^{90} and other isotopes.

The USPHS network has been of value in indicating sites of high airborne activity and possible relation to high fallout deposition. The data have been valuable also in meteorological interpretation of cloud trajectories following tests. Table 13 shows the locations of stations in the current network.

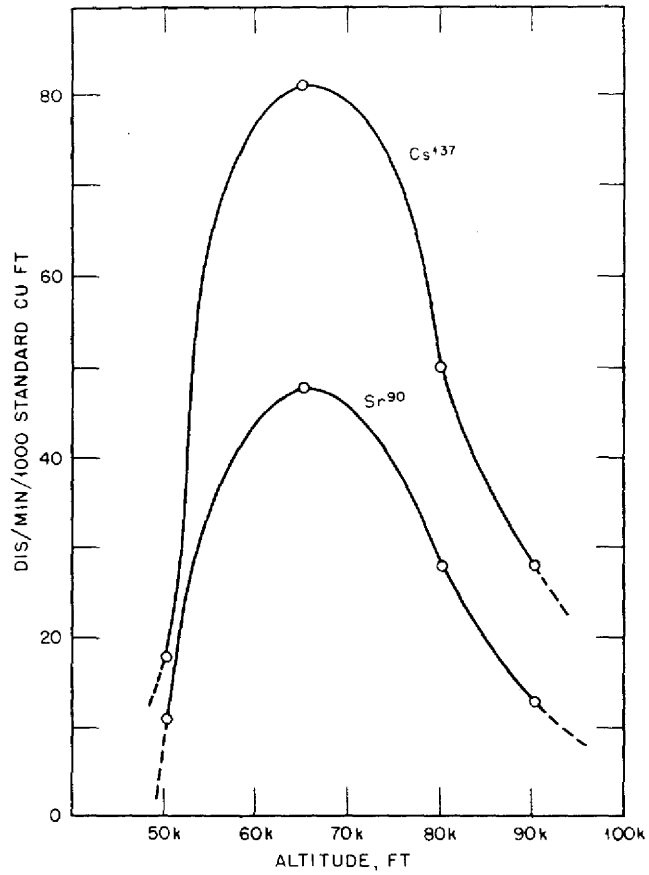

Fig. 7a—Variation of Sr^{90} and Cs^{137} activity with altitude.

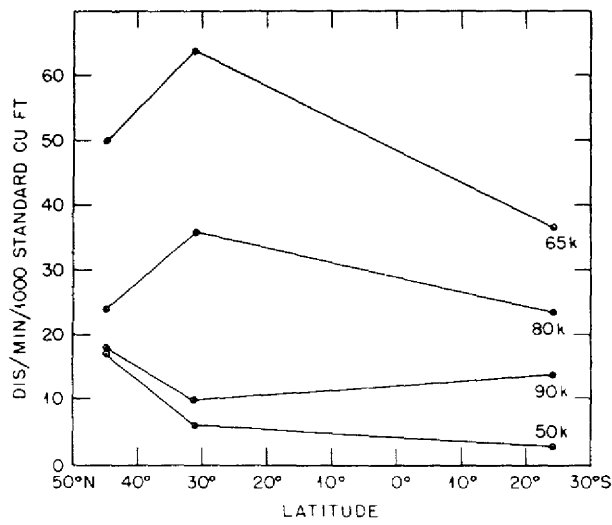

Fig. 7b—Variation of Sr^{90} activity with latitude.

2.2 HIGH-ALTITUDE SAMPLES

A series of high-altitude samples, starting in late 1956, has been taken for radiochemical analysis. The samplers are carried to altitude on balloons, and an attempt is made to obtain total volumes of approximately 1000 std. cu ft. Four sampling sites are used: Minneapolis, Minn., San Angelo, Texas, the Panama Canal Zone, and Sao Paulo, Brazil. An attempt is made to obtain monthly samples at four nominal altitudes: 50,000, 65,000, 80,000, and 90,000 ft. In addition to the difficulty of controlling sample flights at altitude for the required length of time, a number of samples are not recoverable or are otherwise lost. Therefore, fewer than 16 samples per month are usually available. The detailed data on the completed monthly samples taken during 1957 are given in Table 15.

Although the complete interpretation of this type of data requires meteorological knowledge, there are some interesting points that can be made using average values for various groups of samples. The average values for Sr^{90} and Cs^{137} at each altitude and at the three stations submitting sufficient samples are given in Table 14. The averages in Table 14 will not necessarily agree with the averages taken from Table 15 since some additional data on Sr^{90} and Cs^{137} were available from incomplete samples.

The over-all average values for Sr^{90} and Cs^{137} for all stations at the four nominal altitudes are plotted in Fig. 7a. The distribution with altitude of both isotopes shows a maximum at the nominal 65,000 ft regardless of whether the activity is expressed on the basis of standard cubic feet of air or cubic feet of space. The same distribution holds for the individual stations.

The curve may be integrated by using this set of mean values in terms of cubic feet of space to show the presence of a mean of 0.25 megacurie of Sr^{90} in the stratosphere during 1957. If the estimated efficiency factor of the stratospheric filters of 25 per cent is assumed to be correct, a mean stratospheric content of 1 megacurie of Sr^{90} would be obtained.

The cesium to strontium ratio is considerably higher than would be expected from thermal neutron data, and the ratio is sufficiently constant to make it appear that this is a real difference.

If the mean values at the various altitudes are plotted against latitude, there is no indication of any particular trend. The over-all mean, for example, at Minneapolis is 29; Texas, 28; and Sao Paulo, 23 dis/min/1000 cu ft. The values for the individual latitudes are plotted in Fig. 7b.

This sampling program is continuing, and with detailed interpretation it should be of considerable assistance in material balance studies for Sr^{90} .

Certain data have been presented for lower altitudes by the United Kingdom, but no direct comparison is presently possible for tropospheric and stratospheric air concentrations at the same location.

Surface air filter data at Washington, D. C., showed a mean of 70 dis/min/1000 cu ft for total mixed fission products for 1957. This may be compared with the maximum of 3000 dis/min/1000 cu ft found as a mean for the 65,000-ft stratosphere samples. Surface concentrations are hence much lower than stratosphere concentrations, and it is expected that the general tropospheric activity would be intermediate.

Table 12a—Sr⁹⁰ SURFACE AIR CONCENTRATION,
WASHINGTON, D. C.
(Analyses at University of Chicago)

Air filter samples provided by I. H. Blifford, Naval Research Laboratory, Washington, D. C. Collections were made on Army Chemical Corps Type V filters, 200 sq in. area of heavy asbestos fiber composition.

Collection No.	Collection Period	Volume, cu ft × 10 ⁻⁶	Sr ⁹⁰ /10 ⁶ cu ft, dis/min
204D	Apr. 5-8, 1953	4.5	18.6 ± 0.7
204A	Oct. 2-6, 1953	1.7	41.1 ± 3.0
204B	Oct. 6-9, 1953	3.4	30.5 ± 1.1
130	Oct. 12-15, 1953	3.4	70 ± 12
514-P	Apr. 3-5, 1954	2.92	91 ± 7
204E	Apr. 8-10, 1954	2.6	6.4 ± 0.2
204C	Apr. 9-11, 1954	1.7	125 ± 5
204F	Apr. 10-12, 1954	3.4	258 ± 6
515-P	Apr. 12-14, 1954	1.95	65.5 ± 4.6
204G	Apr. 15-17, 1954	3.7	11.0 ± 0.5
204H3	Apr. 17-19, 1954	2.8	20.7 ± 0.6
516-P	Apr. 29-May 1, 1954	3.0	32.2 ± 2.6
895-P	May 5-7, 1954	2.33	210 ± 12
517-P	May 11-13, 1954	2.76	31.3 ± 2.2
896-P	May 17-19, 1954	2.59	120 ± 7
518-P	May 24-26, 1954	2.61	216 ± 11
897-P	May 28-30, 1954	3.80	133 ± 7
519-P	June 1-3, 1954	2.90	68.3 ± 4.1
898-P	June 14-17, 1954	4.45	79 ± 6
899-P	June 23-26, 1954	3.79	51 ± 3
520-P	July 16-17, 1954	1.88	47.0 ± 2.4
521-P	July 24-26, 1954	2.56	73.5 ± 5.2
522-P	July 26-29, 1954	3.66	48.0 ± 3.9
900-P	July 30-Aug. 2, 1954	2.95	200 ± 10
901-P	Aug. 2-7, 1954	5.41	59 ± 5
902-P	Aug. 7-9, 1954	2.92	210 ± 13
903-P	Aug. 28-29, 1954	1.82	380 ± 25
904-P	Oct. 1-3, 1954	3.39	112 ± 7
905-P	Oct. 5-8, 1954	3.56	104 ± 6
906-P	Oct. 16-18, 1954	2.69	198 ± 14
907-P	Oct. 26-28, 1954	2.26	251 ± 17
401-P	Nov. 1-3, 1954	2.9	120 ± 7
908-P	Nov. 7-8, 1954	1.15	225 ± 14
909-P	Nov. 15-16, 1954	1.28	175 ± 10
910-P	Nov. 22-25, 1954	1.96	194 ± 11
402-P	Dec. 1-2, 1954	1.6	103 ± 4
411-P	Jan. 3-4, 1955	1.26	281 ± 6
412-P	Feb. 5-6, 1955	1.7	127 ± 5
413-P	Feb. 10-12, 1955	2.9	241 ± 10
913-P	Feb. 17-18, 1955	1.51	191 ± 11
523-P	Feb. 22-23, 1955	1.41	202 ± 11
524-P	Mar. 3-4, 1955	1.76	270 ± 13
525-P	Mar. 7-8, 1955	1.54	394 ± 20
526-P	Mar. 13-14, 1955	1.07	267 ± 16
527-P	Mar. 16-17, 1955	1.62	310 ± 15
914-P	Mar. 21-23, 1955	2.27	98 ± 7
528-P	Mar. 22-23, 1955	1.74	393 ± 20
529-P	Mar. 27-28, 1955	1.80	24 ± 5
773-P	Apr. 4-5, 1955	1.32	84 ± 4
774-P	Apr. 11-12, 1955	1.93	71.5 ± 3.3

Table 12a (Continued)

Collection No.	Collection period	Volume, cu ft $\times 10^{-6}$	Sr ⁹⁰ /10 ⁶ cu ft, dis/min
775-P	Apr. 18-19, 1955	2.27	85 \pm 6
776-P	Apr. 25-26, 1955	1.82	22.5 \pm 1.4
777-P	May 2-3, 1955	1.34	709 \pm 52
778-P	May 10-11, 1955	1.54	265 \pm 12
779-P	May 17-18, 1955	1.37	478 \pm 16
780-P	May 24-25, 1955	1.69	755 \pm 33
917-P	June 16-17, 1955	1.43	710 \pm 40
918-P	Aug. 5-8, 1955	3.0	300 \pm 20
919-P	Aug. 12-16, 1955	4.51	49 \pm 4
920-P	Aug. 19-22, 1955	3.5	124 \pm 6
921-P	Aug. 26-29, 1955	3.6	226 \pm 16
922-P	Sept. 26-27, 1955	1.53	158 \pm 9
923-P	Sept. 29-30, 1955	1.69	124 \pm 8

Table 12b—Sr⁹⁰ SURFACE AIR CONCENTRATION, FOREIGN LOCATIONS

There is considerable uncertainty in the air volumes of samples collected at Kodiak, Alaska, Port Lyautey, French Morocco, and Yokosuka, Japan, because the flow rate is not directly recorded. For the earliest reports of air filter data for these three locations, the rated flow rate times the total collection period was taken as the collected air volume. Because the flow rate falls off substantially as dust accumulates on the filter, those samples were over-estimated in volume and thus the reported air concentration data were too low. It is considered that a better estimate of their air volume is provided by the average Washington, D. C. volumes for equivalent collection periods. On this basis, the relative air concentration data should be considerably improved, although their absolute value may be in error by as much as 50 per cent. All the earlier reported air filter data for Kodiak, Port Lyautey, and Yokosuka have been estimated on this basis, and the new results are presented below.

Collection No.	Collection period	Volume, cu ft $\times 10^{-6}$	Sr ⁹⁰ /10 ⁶ cu ft, dis/min
Kodiak, Alaska			
924-P	May 27-June 3, 1952	~4.4	~4.8
926-P	June 5-July 1, 1952	~4.5	~6.7
925-P	June 11-17, 1952	~4.3	~9.5
927-P	July 8-16, 1952	~4.4	~6.8
928-P	July 24-29, 1952	~4.2	~4.9
929-P	Aug. 29-Sept. 4, 1952	~4.2	~1.1
930-P	Sept. 18-25, 1952	~4.2	~1.1
931-P	Oct. 9-16, 1952	~4.2	<1.0
932-P	Oct. 23-30, 1952	~4.2	0.7 \pm 0.2
131	Nov. 18-23, 1953	~4.2	~50
205C	Feb. 2-15, 1954	~4.3	~27
205D2	Feb. 15-18, 1954	~3.6	~2.2
205E	Feb. 18-22, 1954	~4.0	~10
933-P	Mar. 17-22, 1954	~4.2	~36
934-P	Apr. 19-26, 1954	~4.4	~61
935-P	May 17-24, 1954	~4.4	~48
936-P	June 14-21, 1954	~4.4	~90
937-P	July 19-26, 1954	~4.4	~31
939-P	Sept. 24-26, 1954	~3.0	~35
940-P	Oct. 15-18, 1954	~3.6	~6.1

Table 12b (Continued)

Collection No.	Collection Period	Volume, cu ft $\times 10^{-6}$	Sr ⁹⁰ /10 ⁶ cu ft, dis/min
403-P	Oct. 30–Nov. 1, 1954	~3.0	~21
941-P	Nov. 20–22, 1954	~3.0	~17
404-P	Dec. 1–2, 1954	~1.9	~180
942-P	Dec. 16–19, 1954	~3.6	~74
414-P	Jan. 1–2, 1955	~1.9	~240
415-P	Feb. 1–2, 1955	~1.9	~230
535-P	Mar. 1–3, 1955	~3.0	~71
781-P	Apr. 1–3, 1955	~3.0	~200
782-P	Apr. 30–May 2, 1955	~3.0	~62
783-P	June 30–July 1, 1955	~1.9	~180
943-P	Aug. 5–7, 1955	~3.0	~53
944-P	Sept. 1–3, 1955	~3.0	~140
Port Lyautey, French Morocco			
206B	July 9–11, 1953	~3.0	~14
206C	July 11–13, 1953	~3.0	~54
206D	July 13–16, 1953	~3.6	~15
206A2	Sept. 30–Oct. 1, 1953	~1.9	~22
206E1	Nov. 2–9, 1953	~4.4	~26
405-P	Nov. 8–9, 1954	~1.9	~140
949-P	Nov. 21–22, 1954	~1.9	~180
406-P	Dec. 3–4, 1954	~1.9	~200
416-P	Jan. 4–6, 1955	~3.0	~53
530-P	Feb. 28–Mar. 2, 1955	~3.0	~500
531-P	Mar. 6–8, 1955	~3.0	~390
532-P	Mar. 16–18, 1955	~3.0	~280
533-P	Mar. 22–24, 1955	~3.0	~110
784-P	Apr. 1–3, 1955	~3.0	~390
950-P	Apr. 15–17, 1955	~3.0	~590
785-P	May 1–3, 1955	~3.0	~640
951-P	May 15–17, 1955	~3.0	~150
786-P	May 31–June 2, 1955	~3.0	~1300
952-P	June 14–16, 1955	~3.0	~310
953-P	June 29–July 1, 1955	~3.0	~130
Yokosuka, Japan			
417-P	Feb. 1–3, 1955	~3.0	~150
534-P	Mar. 1–3, 1955	~3.0	~200
787-P	Apr. 1–3, 1955	~3.0	~12
788-P	May 1–3, 1955	~3.0	~270
789-P	June 1–3, 1955	~3.0	~110
945-P	Aug. 1–3, 1955	~3.0	~14
946-P	Aug. 15–17, 1955	~3.0	~170
947-P	Sept. 1–3, 1955	~3.0	~12
948-P	Sept. 23–25, 1955	~3.0	~70

Table 13—UNITED STATES PUBLIC HEALTH
SERVICE STATIONS MEASURING TOTAL
FISSION PRODUCT ACTIVITY IN AIR
SAMPLES

Albany, N. Y.	Juneau, Alaska
Anchorage, Alaska	Klamath Falls, Oreg.
Atlanta, Ga.	Lansing, Mich.
Austin, Texas	Lawrence, Mass.
Baltimore, Md.	Little Rock, Ark.
Berkeley, Calif.	Los Angeles, Calif.
Bethesda, Md.	Mercury, Nev.
Boise, Idaho	Minneapolis, Minn.
Cheyenne, Wyo.	New Orleans, La.
Cincinnati, Ohio	Oklahoma City, Okla.
Denver, Colo.	Phoenix, Ariz.
Des Moines, Iowa	Pierre, S. D.
El Paso, Texas	Portland, Oreg.
Gastonia, N. C.	Richmond, Va.
Harrisburg, Pa.	Salt Lake City, Utah
Hartford, Conn.	Sante Fe, N. Mex.
Honolulu, T. H.	Seattle, Wash.
Indianapolis, Ind.	Springfield, Ill.
Jacksonville, Fla.	Trenton, N. J.
Jefferson City, Mo.	

Table 14—STRATOSPHERIC DATA, 1957

Station	Altitude, km			
	50	65	80	90
Average Sr ⁹⁰ dis/min/1000 cu. ft. of air at STP				
Minneapolis	17	50	24	18
Texas	6	64	36	10
Brazil	3	37	24	14
Mean*	11	48	28	13
Average Cs ¹³⁷ dis/min/1000 cu. ft. of air at STP				
Minneapolis	21	80	34	20
Texas	16	129	70	24
Brazil	12	52	43	40
Mean*	18	81	50	28

* Mean of individual values.

Table 15—HIGH-ALTITUDE SAMPLING DATA

HASL Sample No.	Flight No.	Flight date	Nominal altitude, 10 ³ ft	Actual altitude, 10 ³ ft	Tropopause height, 10 ³ ft	Volume, standard cu ft	Total activity			Ba ¹⁴⁰		Dis/min/1000 standard cu ft.					
							Counting date	Dis/min/ sample	Dis/min/ standard cu ft	Counting date	Dis/min/ sample	Zr ⁹⁵	Ce ¹⁴⁴	Cs ¹³⁷	Sr ⁸⁹	Sr ⁹⁰	
January 1957																	
Minneapolis	5134	2051	1/16	50	46/43	32*	11,952	3/22	31,790 ± 990	2.66 ± 0.08	6/20 6/24	≤1.4 ≤5.2	389	395	24	244	24.8
Texas	5172	T-165	1/17	90	105/106.5	S	850	3/22	≤650	≤0.76	6/20 6/24	≤1.4 ≤1.4	106	41.3	7.65	≤393	7.65
	5173	T-167	1/18	65	65	36.8*	3,857	3/22	34,150 ± 1,400	8.85 ± 0.36			863	2662	227		
Panama	5232	P-145	1/21	65	65	53.1*	3,459	3/25	2,930 ± 850	0.85 ±	7/10	≤1.9 ≤1.8	93.1	82.2	4.48		
Southern Hemisphere	5279	B-152	1/31	65	65	68.3 ²	3,343	3/22	613 ± 790	0.18 ± 0.24	7/1	≤1.7 ≤0.9	39	134	29.0	55.6	25.9
February 1957																	
Minneapolis	5300	2114	2/13	80	79.7/76.0	S	3,629	3/22	12,300 ± 550	3.39 ± 0.15	7/3	≤0.8 ≤0.9	34.1	16.7	4.82	61.5	0.83
	5321	2130	2/27	50	42.5/39	35.3*	17,499	3/25	21,000 ± 1,120	1.20 ± 0.06			104	156	13.9	75.6	11.7
	5322	2128	2/19	65	66.9/65.1	S	5,444	3/25	2,830 ± 850	0.52 ± 0.16			64.5	98.4	19.2	108	7.26
Texas	5293	T-172	2/9	90	97.25/98.75	S	772	3/22	≤520	≤0.67	7/3	≤1.9 ≤1.0	120	241	25.9	≤276	26.0
	5297	T-174	2/11	65	65.5	S	3,229	3/22	18,275 ± 1,190	5.66 ± 0.37	7/1	≤1.3 ≤1.4	345	1082	49.6	844	136
	5319	T-178	2/27	50	49.0/49.6	36.0*	7,320	3/25	7,400 ± 970	1.01 ± 0.13	7/22	≤1.1 ≤0.7	61.5	120	11.7	60.8	9.9
	5340	T-176	2/25	80	85/85.25	S	1,776	3/25	2,230 ± 750	1.26 ± 0.42	7/22	≤0.7 ≤1.3	60	403	94.6	106	39.7
Panama	5280	P-148	2/1	90	99/104	S	710	3/22	≤560	≤0.8			≤256	2802†	183	103,000†	
	5307	P-150	2/15	65	67.2/59.2	53.1*	4,373	3/22	9,470 ± 800	2.16 ± 0.18	7/10	≤1.1 ≤1.0	132	370	23.2	230	38
	5435	P-154	2/28	80	78	S	2,180	3/25	8,080 ± 880	3.71 ± 0.40			227	734	99.5	3563†	35
Southern Hemisphere	5393	B-158	2/21	90	89.5	S	843	3/25	≤640	≤0.76			89.8	64.2	40.9	135	9.49
	5394	B-159	2/22	65	66	S	2,830	3/25	1,780 ± 700	0.63 ± 0.25	7/22	≤1.1 ≤0.7	≤27.0	160	83	109	29.8
	5395	B-160	2/23	80	92/71.6	S	1,421	3/22	19,900 ± 590	14.0 ± 0.42	7/31	≤1.3 ≤1.1	<7.0	139	72.5	<335	31

Table 15 (Continued)

HASL Sample No.	Flight No.	Flight date	Nominal altitude, 10 ³ ft	Actual altitude, 10 ³ ft	Tropopause height, 10 ³ ft	Volume, standard cu ft	Total activity			Ba ¹⁴⁰		Dis/min/1000 standard cu ft.				
							Counting date	Dis/min/ sample	Dis/min/ standard cu ft	Counting date	Dis/min/ sample	Zr ⁹⁵	Ce ¹⁴⁴	Cs ¹³⁷	Sr ⁸⁵	Sr ⁹⁰
March 1957																
Minneapolis	5448	2151	3/13	65	65.7/55	32*	8,024	4/5	12,250 ± 990	2.27 ± 0.12		185	598	87.9	203	69.8
	5449	2173	3/19	50	49.5/47	31.5*	8,900	4/5	12,050 ± 1,010	1.35 ± 0.11		89.9	186	26.4	99.7	20.4
	5470	2182	3/21	80	81.5/55	S	4,718	4/5	11,840 ± 1,470	2.51 ± 0.31		128	435	43.5	362	44.2
	5533	2185	3/27	90	67.4/98.5	S	2,395	5/7	3,060 ± 730	1.28 ± 0.30		90.6	220	41.5	≤131	25
Texas	5440	T-183	3/11	80	77.5/78.5	S	2,007	3/25	922 ± 890	0.46 ± 0.44		116	254	75.2	≤146	28.4
	5441	T-185	3/12	90	94/95	S	1,079	4/5	860 ± 803	0.8 ± 0.74		179	68.9	42.6	(<859)	6.58
Panama	5437	P-160	3/6	80	80.1/81.6	S	1,828	3/25	2,970 ± 850	1.62 ± 0.46		199	566	68.9	104	46.5
	5467	P-162	3/8	90	89.2/96.0	S	940	4/5	≤830	≤0.88		≤188	27.3	30.3	≤502	≤2.93
	5468	P-163	3/9	65	64.5/63.1	57.3*	3,109	4/5	6,980 ± 960	2.24 ± 0.31		191	440	49.7	281	47.4
Southern Hemisphere	5442	B-162	3/8	90	90	S	969	4/5	≤560	≤0.58		273	69.7	69.7	≤184	18.3
	5524	B-166	3/23	80	81.5	S	644	5/7	≤750	≤1.16		≤234	171	82.7	≤228	20.5
	5526	B-167	3/23	65	66	S	2,473	5/7	4,780 ± 750	1.93 ± 0.30		≤72.6	188	73.6	≤191	41.0
	5528	B-171	3/27	80	80.8	S	1,769	8/26	1,680 ± 500	0.95 ± 0.28		172	346	84.8	≤256	32.5
April 1957																
Minneapolis	5563	2190	4/8	65	65/37	31.1*	14,211	5/7	19,890 ± 1,240	1.4 ± 0.09		54.0	233	28.4	≤53.5	24.8
	5593	2201	4/15	50	47.5	39.5*	6,180	5/7	35,790 ± 1,440	5.79 ± 0.23		183	284	51.8	510	33.5
	5594	2203	4/17	80	81.5/74.35	S	3,731	5/7	34,840 ± 1,240	9.34 ± 0.33		372	428	42.8	351	37.5
	5560	2217				S										
	5685	2218	4/29	65	67.6/68	S	3,120	6/17	17,820 ± 989	5.71 ± 0.32		263	1038	222	(<820)	138
Texas	5636	T-193	4/17	90	89.5	S	2,689	5/7	1,600 ± 650	0.6 ± 0.24		-58.6	8.08	4.83	≤56.4	≤1.12
Panama	5591	P-165				S										
	5592	P-167	4/12	65	61.75/61	56.3*	4,082	5/7	4,300 ± 770	1.05 ± 0.19		75	232	1.10	≤137	27.4
Southern Hemisphere	5637	B-173	4/9	90	90.4	S	894	5/7	940 ± 650	1.05 ± 0.73		≤245	1021	≤15.7	(<886)	14.6
	5638	B-176	4/12	80	78.6/>>90	S	1,253	5/7	1,390 ± 670	1.11 ± 0.53		≤89	54.4	39.9	(<618)	14.4
	5695	B-178	4/23	80	68.5/90	S	1,179	5/18	1,900 ± 590	1.61 ± 0.50		132	353	33.4	≤569	58.1
	5696	B-179	4/23	65	64	48.0*	3,340	5/18	3,200 ± 640	0.96 ± 0.19		46.8	176	74.8	≤207	44.5
	5697	B-131	4/25	80	78/80.5	S	1,561	5/18	2,470 ± 370	1.58 ± 0.24		≤103	294	86.5	≤134	42.6
May 1957																
Minneapolis	5823	2234	5/11	65	62.1/61.7	38.8*	5,810	6/17	15,900 ± 1,100	2.74 ± 0.19		103	479	102	(448)	58
	5876	2240	5/16	80	78/78.5	S	3,883	6/17	1,450 ± 580	0.37 ± 0.15		≤16.7	33.3	14.2	≤97.1	4.78
	6025	2196	5/27	65	62.2/62.9	37.6*										
	6026	2255	5/27	90	72.5/90.4	S	1,916	7/19	13,400 ± 680	6.99 ± 0.35		846	1502	59.5	<375	78.3
	6039	2213	5/29	80	77.2/73.1	S	3,952	7/19	2,440 ± 830	0.62 ± 0.21		43.5	208	43.4	≤35.2	28.6

Texas	5694	T-197	5/2	80	81.5	S	1,945	6/17	1,700 ± 640	0.87 ± 0.33	76.6	197	77.4	≤179	19.3
	5722	T-198	5/3	65	66.5	S	1,824	6/17	4,490 ± 810	2.46 ± 0.44	183	532	113	≤583	58.1
	5870	T-199	5/10	50	48.75	39.1*	1,915	6/17	≤580	≤0.30	≤30	16.0	≤4.18	≤79	≤1.64
	5871	T-200				35.9*									
	5875	T-202				S									
	5970	T-203				42.0*									
Panama	6005	P-176				55.0*									
Southern Hemisphere	6006	B-185	5/14	65	65.3		1,796	7/19	≤620	≤0.34	≤145	127	31.5	<277	32.3
	6009	B-188	5/17	80	80/79.1	S	1,655	7/17	1,030 ± 760	0.62 ± 0.46	<139	39.1†	61.9	<263	42
	6012	B-191				S									
June 1957															
Minneapolis	6331	2222				S									
	6334	2235				36.3*									
	6335	2236				44.75*									
Texas	6085	T-205	6/6	90	90.9	S	1,219	7/19	1,320 ± 670	1.08 ± 0.55	≤82.1	26.4	14.4	≤62.1	1.52
	6102	T-204	6/6	90	73.4/89.4	S	1,028	7/19	1,790 ± 740	1.74 ± 0.72	152	278	80.2	≤81.4	32.1
	6103	T-206	6/7	80	79.7/80.1	S	2,441	7/19	1,440 ± 690	0.59 ± 0.28	43.5	101	27.4	≤22.2	9.69
	6104	T-207	6/11	65	66.8/67.6	S	1,736	7/19	3,440 ± 890	1.98 ± 0.51	163	337	152	≤80.3	52.1
	6203	T-210													
Panama	6105	P-177													
Southern Hemisphere	6175	B-194	6/1	90	88.9	S	786	8/26	3,790 ± 540	4.82 ± 0.69	≤333	682	105	≤248	57.9
	6176	B-195	6/2	65	66.2/63.5	53.9*	1,265	8/26	1,410 ± 450	1.11 ± 0.36	412	138	8.03	388	4.47
	6177	B-196	6/2	90	93.3/95.9	S	1,278	8/26	2,020 ± 540	1.58 ± 0.42	223	406†	95.8	<421	47.3
	6305	B-198	6/13	90	93.5	S	949	8/26	2,030 ± 460	1.08 ± 0.48	333	138†	13.2	(<415)	<3.69
	6306	B-199	6/14	80	77.1/81.1	S	1,788	8/26	1,748 ± 540	0.98 ± 0.30	<87	212	16.5	≤160	28.5
	6307	B-200	6/15	50	49.3	40.1*	1,926	8/26	1,870 ± 540	0.97 ± 0.28	125	74.3	24.9	(<139)	4.93
July 1957															
Minneapolis	6426	2237		90	88.1/88.7	S	1,738	8/26	1,210 ± 670	0.70 ± 0.38	<79.2	18.5	11.8	<99.8	<1.29
	6427	2241	7/11	50	50.5/50.7	46.3*	7,174	9/17	7,330 ± 860	1.02 ± 0.12	222	176	10.9	112	7.04
	6428	2242		65	61.7/62.4	46.3*									
	6429	2244		80	76.0/76.4	S									
	6494	2246		65	59.9/61.7	47.3*	2,145	9/17	10,620 ± 800	4.95 ± 0.37	304	976	233	<390	122
	6566	2447		90	90.0/90.8	S									
Texas	6406	T-212		90	87.0/87.4	S									
	6408	T-214		80	80.8/81.5	S	1,809	8/26	3,570 ± 560	1.97 ± 0.31	119	428*	127	<332	42.0
	6425	T-215		50	48.9	47.0*									
Southern Hemisphere	6456	B-201		65	64.8/65.5										
	6457	B-202		90	92.5/92.7	S									
	6458	B-204		80	78.1/74.4	S	2,173	9/17	2,600 ± 890	1.20 ± 0.41	<53.9	207	65.8	<126	21.1
	6459	B-205		50	48.1/48.9	47.9*	1,899	9/17	2,017 ± 630	1.06 ± 0.33	558	206	<4.48	<44.3	1.18

Table 15 (Continued)

HASL Sample No.	Flight No.	Flight date	Nominal altitude, 10 ³ ft	Actual altitude, 10 ³ ft	Tropopause height, 10 ³ ft	Volume, standard cu ft	Total activity			Ba ¹⁴⁰		Dis/min/1000 standard cu ft						
							Counting date	Dis/min/ sample	Dis/min/ standard cu ft	Counting date	Dis/min/ sample	Zr ⁹⁵	Ce ¹⁴⁴	Ca ¹³⁷	Sr ⁸⁹	Sr ⁹⁰		
August 1957																		
Minneapolis	6605	2248	50	48.6/49.1	45.7*	5,174	9/17	6,064 ± 800	1.17 ± 0.15			220	116	7.63	89.8	3.07		
	6610	2249	90	89.6/91.5	S													
	6661	2253	90	88.9	S													
	6695	2256	65	64.0	41.1*													
Texas	6653	T-217	65	64.9	50.6*	1,660	9/17	4,670 ± 690	2.81 ± 0.42			128	453	103	136	52.1		
	6654	T-218	90	89.4/91.8	S													
Southern Hemisphere	6697	B-207	65	64.0/66.0		1,232	9/17	1,100 ± 720	0.89 ± 0.58			160	221‡	78.7	196	35.7		
	6698	B-209	50	49.0														
	6700	B-211	80	79.2/79.8	S													
	6701	B-214	90	90.1	S	993	9/17	2,390 ± 700	2.41 ± 0.70			-67.6	110	48.2	109	17.6		
September 1957																		
46 Minneapolis	6805	2263	50	46.6/45.9	38.9*													
	6827	2265	80	77.5/77.2	S													
	6849	2268	65	63.2	39.8*													
	6932	2269	65	63.0	32.6*													
Texas	6758	T-221	90	90.1	S													
	6850	T-222	80	80.5	S													
	6851	T-223	65	64.7	50.9*													
	6914	T-224	50	49.3/50.7	44.0*													
Southern Hemisphere	6879	B-216	65	64.2		1,586	9/26	1,800 ± 640	1.13 ± 0.40	≤59.7		84.4	138	60.5	92.5	25.2		
	6881	B-219	80	80.2	S	2,288	9/26	930 ± 540	0.41 ± 0.24	≤51.4	≤24.2	18.5	7.65	<33.0	2.58			
October 1957																		
Minneapolis	6980	2276	50	48.4/49.2														
Texas	6981	T-225	50	49.8	48.5*													
	6982	T-226	90	91.25/90.75	S	1,062	10/9	4,550 ± 790	4.28 ± 0.74	248	185	119	24.5	111	4.66			
	6996	T-227	80	82.5	S													
	6997	T-228	65	63.5														
Southern Hemisphere	7059	B-223	90	89.5	S													
	7060	B-224	10/9	80.2	S	1,832	10/25	621 ± 100	0.34 ± 0.054	≤10.5	≤26	45.3‡	15.6	≤12.3	3.77			
	7063	B-227	65	67.2		1,790	10/25	925 ± 120	0.52 ± 0.067	12.7	50.9	173‡	88.3	88.4	22			

November 1957

Minneapolis	7257	2299		80	78.6/79.0	S												
	7258	2301	11/30	65	63.7/64.3		3,617	12/12	3,780 ± 630	1.04 ± 0.17	73.7	92.8	141	32.4	110	14.6		
Texas	7234	T-231		80	81.0/80.2	S												
	7235	T-232		50	47.5													
	7256	T-236		65	66.0/65.5													
	7340	T-235		65	66													
Southern Hemisphere	7301	B-231		80	80/79.5													

December 1957

Minneapolis	7259	2302	12/4	50	46.7/47.5		4,265	12/12	27,570 ± 1,380	6.46 ± 0.32	216	878	590	39.7	393	23.4		
	7272	2304		80	81.1/81.5	S												
	7341	2305		65	63.45													
	7423	2303		90	88.1/88.6	S												
Texas	7289	T-237		90	92.7	S												
	7277	T-238		80	80.4	S												
	7278	T-239		50	48.8	48.0*												
	7296	T-242		65	62.4													
Panama	7288	P-211		90	89.5/88.3	S												
	7297	P-212		65	65.9/65.5													
Southern Hemisphere	7424	B-234	12/10	80	81.2/80.3	S	1,821	1/16	≤540	≤0.30	<24.4	<14.8	111	66.4	<24.8	23.1		
	7425	B-236	12/12	65	65.5/65.8		1,571	1/16	≤560	≤0.36	<15.1	31.6	129	45.5	55.9	23.9		
	7427	B-239	12/14	50	51.5/51.2		2,744	1/16	≤560	≤0.20	<7.1	5.26	1.98	1.28	7.31	1.42		

*Stratospheric sample.

†Sample contaminated with cerium and strontium.

‡New factor used.

3. WATER

3.1 TAP WATER

New York City tap water has been sampled since August of 1954. Daily samples are pooled to obtain a total volume of about 100 liters for the monthly period. Results are tabulated in Table 16 and are plotted in Fig. 8.

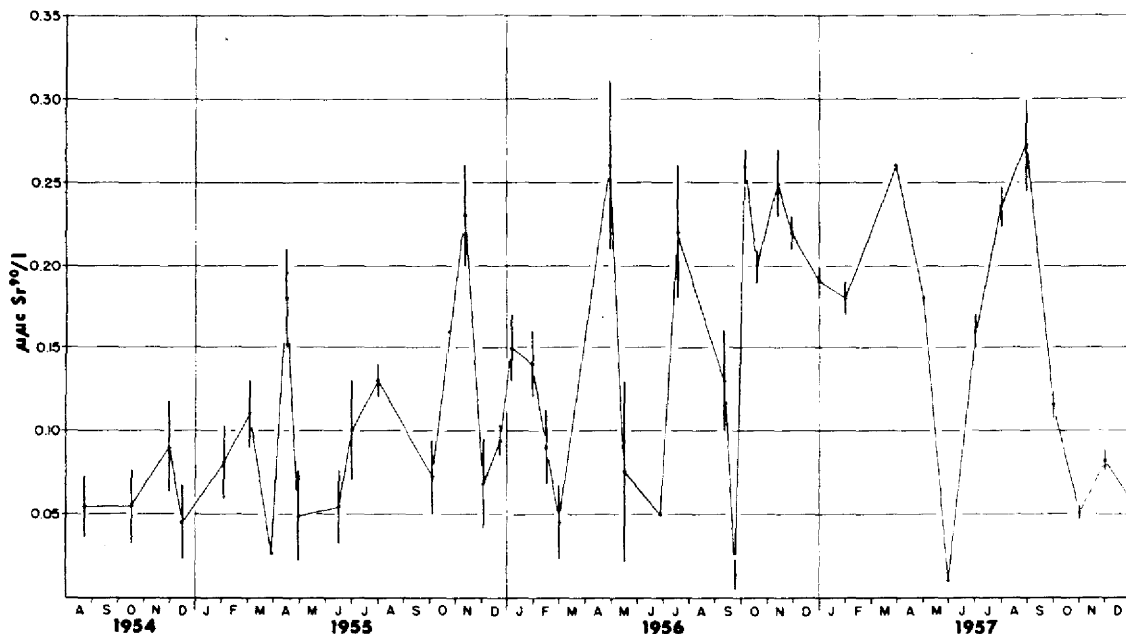

Fig. 8—Sr⁹⁰ in New York City tap water.

Earlier samples have been reported from both the University of Chicago and the Lamont Geological Observatory. The results of these analyses are presented in Table 17.

3.2 RIVER, PRECIPITATION, AND RESERVOIR WATER

As part of a study in marine waste disposal being conducted by the Agriculture and Mechanical College of Texas, samples of river water from the Mississippi drainage system were analyzed for Sr⁹⁰. Additional water samples were collected at the southwest pass of the Mississippi Delta. The results are shown in Table 18.

Data obtained on surface waters at the laboratories of the University of Chicago and the Lamont Geological Observatory are shown in Table 19.

3.3 SEA WATER

The area of the oceans is much greater than that of the land masses; therefore a large fraction of fallout is probably deposited in the sea. The sea is a mobile system, and deposition

during a particular period may be carried thousands of miles by the ocean currents in a year. In addition, the processes of precipitation and scavenging going on in the ocean tend to distribute individual isotopes quite differently than those found on land. A portion of the deposited activity will precipitate and settle to the ocean bottom, where it is relatively unavailable. Other material may be concentrated by marine organisms and may appear at relatively high levels in the food chain. It is of interest, however, to attempt to develop a picture of the distribution of the radioactive isotopes in the sea, both geographically and as a function of depth.

A large proportion of the measurements made have indicated levels such that very large samples are required for radiochemical analysis for individual isotopes. Therefore the results of most of the work have been reported in terms of mixed fission product activity. These data, like other mixed fission product analyses, are extremely difficult to interpret in themselves. Their value lies in indicating areas of higher activity and thus for possible sampling locations for Sr^{90} or Cs^{137} analysis.

Early radiochemical data from the University of Chicago and from the Lamont Geological Observatory are reported in Table 20. More recent data developed by Dr. Vaughan T. Bowen of the Woods Hole Oceanographic Institution and Dr. Thomas Sugihara of Clark University are shown in Table 21. The Clark University group is continuing investigations of geographic and depth distribution in the Atlantic Ocean.

Through the cooperation of the U. S. Navy, samples of surface sea water were collected in the Pacific from July 1956 into early 1958. Samples are taken during normal transport operations at about 100-mile intervals on several of the routes in the western Pacific.

One-liter samples are obtained, and these are analyzed for mixed fission product activity only. During the collection period well over 1000 of these samples were analyzed. The individual data are not tabulated since mixed fission product activities are not directly convertible to strontium or other single isotopes; however, a list of the cruises and the maximum activity obtained on each is presented in Table 22.

Table 16—Sr⁹⁰ IN NEW YORK CITY TAP WATER

Sampling period	Sr ⁹⁰ , μμc/liter	Sampling period	Sr ⁹⁰ , μμc/liter
1954		2/16-3/1	0.045 ± 0.022
8/13-8/20	0.054 ± 0.018	4/20-4/30	0.26 ± 0.05
10/4-10/15	0.054 ± 0.022	5/1-5/15	0.076 ± 0.054
11/17-11/29	0.090 ± 0.027	5/16-6/27	≤0.050
11/30-12/13	0.045 ± 0.022	6/28-7/17	0.22 ± 0.04
12/14-2/3/55	0.081 ± 0.022	8/27-9/12	0.13 ± 0.03
		9/12-9/22	0.014 ± 0.009
		9/22-10/5	0.26 ± 0.01
1955		10/5-10/17	0.20 ± 0.01
2/4-3/3	0.11 ± 0.02	10/30-11/13	0.25 ± 0.02
3/4-3/29	≤0.027	11/14-11/27	0.22 ± 0.01
3/30-4/15	0.18 ± 0.027	December	0.19 ± 0.01
4/16-4/29	0.049 ± 0.027		
5/21-6/15	0.054 ± 0.022	1957	
6/16-6/31	0.10 ± 0.03	January	0.18 ± 0.01
8/5-9/1	0.13 ± 0.01	March	0.26 ± 0.004
9/2-10/3	0.072 ± 0.022	April	0.18 ± 0.002
10/4-11/3	0.23 ± 0.03	May	0.007 ± 0.004
11/4-12/2	0.068 ± 0.027	June	0.16 ± 0.01
12/3-12/19	0.094 ± 0.009	July	0.235 ± 0.012
12/20-1/5/56	0.15 ± 0.02	August	0.272 ± 0.027
		September	0.115 ± 0.008
1956		October	0.051 ± 0.004
1/6-1/31	0.14 ± 0.02	November	0.082 ± 0.006
2/1-2/15	0.090 ± 0.022	December	0.058 ± 0.004

Table 17a—Sr⁹⁰ IN TAP WATER COLLECTED BY THE UNIVERSITY OF CHICAGO

Sample No.	Collection date	Source	Sr ⁹⁰ /liter, μμc
CL-60	Oct. 27, 1953	University of Chicago	0.046 ± 0.0095
CL-687-P	May 1955	Pittsburgh, Pa.	0.138 ± 0.0095
CL-1093-P	Mar. 2-13, 1956	Pittsburgh, Pa.	0.158 ± 0.016

Table 17b—Sr⁹⁰ IN TAP WATER COLLECTED BY THE LAMONT GEOLOGICAL OBSERVATORY

Sample No.	Collection date	Source	Sr ⁹⁰ /liter, μμc
W-2	Feb. 20, 1954	Lamont Observatory	≤0.113
W-16	Mar. 13, 1954	Lamont Observatory	0.187 ± 0.033
W-23	Apr. 13, 1954	Lamont Observatory	≤0.006
W-30	Apr. 10, 1954	SW Bronx, N. Y.	0.164 ± 0.032
W-42	Sept. 1954	Lamont Observatory	0.200 ± 0.020
W-41	Dec. 1954	Lamont Observatory	0.113 ± 0.018
W-65	Mar. 1954	Lamont Observatory	0.117 ± 0.018
W-63	Aug. 5, 1954	Hammerfest, Norway	0.106 ± 0.031

Table 18—MISSISSIPPI RIVER WATER*
(AEC sponsored research program in marine waste disposal;
samples were collected by the U. S. Army Corps of Engineers
for the
Agricultural and Mechanical College of Texas,
Dept. of Oceanography and Meteorology,
Dr. Richard G. Bader, Associate Professor.)

River water samples						
HASL Sample No.	Ref. No.	Location	Collection date, 1957	Water depth, ft	Sample depth, ft	Sr ⁹⁰ /liter, $\mu\mu\text{c}$
5888	1	Clinton, Ill.	5/10			1.11 ± 0.37
5889	2		5/10			0.71 ± 0.04
5914	3	Sioux City, Ia.	5/14			0.38 ± 0.04
5922	4		5/14			0.53 ± 0.04
7125A	1		10/2		2.0	0.59 ± 0.04
7125B	2		10/2		3.0	
5890	5	Kansas City, Mo.	5/8			0.33 ± 0.13
5891	6		5/8			0.68 ± 0.28
5892	7A	St. Louis, Mo.	5/13			0.66 ± 0.02
5893	7B		5/13			
5894	8A		5/13			0.55 ± 0.02
5895	8B		5/13			
7126A	7A2		October	16	2.0	0.80 ± 0.02
7126B	7B2		October	16	6.0	
5923	9	Memphis, Tenn.	5/8			0.73 ± 0.05
5924	10					0.72 ± 0.04
5896	11	Baton Rouge, La.	5/9			0.79 ± 0.04
5897	12					0.32 ± 0.04
7128A	Cont. No. 1		October	75	2	0.89 ± 0.04
7128B	Cont. No. 2		October	75	60	
7127A	8A1	Missouri River, Mile 0.4	October	17	2	0.25 ± 0.02
7127B	8A2		October	17	7	

Mississippi Delta (SW Passage)

HASL Sample No.	Ref. No.	Type sample	Collection date, 1957	Location	Sr ⁹⁰ /liter, $\mu\mu\text{c}$
7119	5A	Water, surface	5/13	28° 53' 32" lat 89° 25' 21" long	0.25 ± 0.04
7120	5B3	Water, 3 fath.	5/13	28° 53' 32" lat 89° 25' 21" long	0.11 ± 0.05
7121	5W	Grab sample, 7 fath.	5/13	28° 53' 32" lat 89° 25' 21" long	0.78 ± 0.24†
7122	IIA	Water, surface	9/28	28° 53' lat 89° 26' long	0.33 ± 0.04
7123	IIB	Water, 3 fath.	9/28	28° 53' lat 89° 26' long	0.20 ± 0.03
7124		Grab sample, 5 fath.	9/28	28° 53' lat 89° 26' long	≤ 0.68†

*Error term is one standard deviation due to counting.

†Water phase only.

Table 19a— Sr^{90} IN RIVER WATER SAMPLES COLLECTED BY THE UNIVERSITY OF CHICAGO

Sample No.	Collection date, 1953	Source	Sr^{90} /liter, $\mu\mu\text{c}$
CL-54	2/4	Mississippi River, Memphis, Tenn.	0.134 ± 0.019
CL-57	4/17	Mississippi River, St. Louis, Mo.	0.092 ± 0.021
CL-112	9/7	Mosel River, Metz, France	≤ 0.006
CL-113	9/8	Seine River, Nogent, France	≤ 0.011
CL-114	9/12	Donau River, Ulm, Germany	≤ 0.008

Table 19b— Sr^{90} IN RESERVOIR AND PRECIPITATION WATER SAMPLES COLLECTED BY THE LAMONT GEOLOGICAL SURVEY OBSERVATORY

Sample No.	Collection date, 1954	Source	Sr^{90} /liter, $\mu\mu\text{c}$
W-1	2/6	Reservoir, Ashoken, N. Y.	-0.008
W-2	2/6	Reservoir Schoharie, Allaben, N. Y.	0.114 ± 0.023
W-5	2/6	Reservoir Rondant, N. Y.	-0.025
W-6	2/6	Reservoir Monroe, N. Y.	0.062 ± 0.035
W-52	8/11	Rain, Flensburg, Germany	0.607 ± 0.039
Rain and Snow			
W-59	12/7	Lamont Observatory	0.343 ± 0.012
W-13	1/11	Lamont Observatory	0.445 ± 0.051
W-12	2/3	Lamont Observatory	0.621 ± 0.056
W-11	2/5	Lamont Observatory	0.334 ± 0.040
W-10	2/17	Lamont Observatory	0.382 ± 0.029
W-9	2/22	Lamont Observatory	0.585 ± 0.051
W-8	2/25	Lamont Observatory	0.274 ± 0.012
W-4	3/3 (2:30 pm)	Lamont Observatory	0.114 ± 0.023
W-7	3/3 (7:30 pm)	Lamont Observatory	0.331 ± 0.042
W-17	3/15	Lamont Observatory	2.17 ± 0.113
W-18	3/19	Lamont Observatory	2.20 ± 0.071
W-19	3/20	Lamont Observatory	1.77 ± 0.019
W-20	3/25	Lamont Observatory	8.32 ± 0.257
W-21	3/27	Lamont Observatory	5.73 ± 0.148
W-22	4/1	Lamont Observatory	12.38 ± 0.36
W-48	4/23	Lamont Observatory	0.349 ± 0.032
W-24	4/24	Lamont Observatory	0.585 ± 0.044
W-25	4/27	Lamont Observatory	0.558 ± 0.017
W-54	6/23	Lamont Observatory	0.494 ± 0.024
W-49	6/25	Lamont Observatory	1.10 ± 0.095
W-45	8/1	Lamont Observatory	1.75 ± 0.073
W-55	9/8	Lamont Observatory	0.200 ± 0.023
W-56	9/9	Lamont Observatory	0.243 ± 0.015
W-58	9/16 (12:00 Noon)	Lamont Observatory	1.48 ± 0.018

Table 19b (Continued)

Sample No.	Collection date, 1954	Source	Sr ⁹⁰ /liter, $\mu\mu\text{c}$
W-51	9/16 (2:00 pm)	Lamont Observatory	0.351 \pm 0.014
W-61	9/20	Lamont Observatory	1.26 \pm 0.036
W-62	9/21	Lamont Observatory	0.506 \pm 0.030
W-57	10/30	Lamont Observatory	1.14 \pm 0.017
W-46	11/2 (11:00 am)	Lamont Observatory	0.512 \pm 0.024
W-47	11/2 (11:00 am)	Lamont Observatory	0.322 \pm 0.020
W-43	11/6	Lamont Observatory	0.581 \pm 0.020
W-50	12/9	Lamont Observatory	0.666 \pm 0.037

Table 20a—Sr⁹⁰ IN SEA WATER COLLECTED BY THE UNIVERSITY OF CHICAGO

Sample No.	Collection date	Source	Sr ⁹⁰ /liter, $\mu\mu\text{c}$
CL-8	May 20, 1953	Santa Monica, Calif. (80 liters)	0.119 \pm 0.048
CL-732	Apr. 9, 1955	Atlantic (48°49' N; 48°07' W)	0.512 \pm 0.036

Table 20b—Sr⁹⁰ IN SEA WATER COLLECTED BY THE LAMONT GEOLOGICAL OBSERVATORY

Sample No.	Collection date	Source	Sr ⁹⁰ /liter, $\mu\mu\text{c}$
W-64	July 10, 1954	39°05' lat, 70°45' long	0.081 \pm 0.018

Table 21—RADIOISOTOPES IN SURFACE WATER*

Year	Lat	Long	Date	Total depth, miles	Isothermal depth, miles	Sr ⁹⁰
Shelf Area						
1956	41°31'N	70°40'W	6/4	5		12.7 ± 3.4
	40°18'N	71° W	2/9	110	75	15.0 ± 3.0
	40° N	71° W	2/10	275	35	30.0 ± 1.6
	39°42'N	71° W	2/10	2000	120	10.3 ± 1.6
	39°10'N	71° W	2/11	2750	150	6.3 ± 1.6
1957	40°19'N	71°29'W	2/14	78	60	12.8 ± 2.0
	39°18'N	71°40'W	2/15	1630	200	8.6 ± 2.0
	39°19'N	72°02'W	2/15	1550	200	6.7 ± 1.7
	39°26'N	72°10'W	2/16	784	175	10.2 ± 2.0
	39°39'N	73°07'W	2/16	39	30	8.6 ± 2.0
	39°46'N	73°57'W	2/16	24	15	18.8 ± 3.0
Southerly Samples						
1956	21°34'N	86°12'W	5/18	500	75	10.0 ± 1.5
	38°17'N	69°02'W	6/4		125	9.1 ± 1.8
	17°49'N	60°07'W	12/9	6600	50	10.3 ± 1.7
	20°15'N	60°05'W	12/10	5340	60	10.0 ± 2.5
	22°00'N	60°09'W	12/11	6300	40	8.1 ± 1.5
	24°50'N	61°55'W	12/12	5700	100	12.0 ± 2.0
	27°47'N	63°41'W	12/13	5120	260	12.2 ± 1.5
1957	21°08'N	33°20'W	2/13	5100	150	4.7 ± 1.0
	8°18'S	7°42.5'W	3/7	4582	20	5.0 ± 1.0
	8°18'S	31°17'W	3/20	5300	125	
	8°16'N	17°19'W	5/8	4600	30	4.5 ± 1.0
	8°17'N	49°15'W	5/18	4400	80	5.4 ± 1.0

*Radioactivity, dis/min/100 liters.

Table 22—SEA WATER SAMPLES

Sample No.	Starting date	Course	Maximum β activity (MFP)		
			Dis/min/liter	Latitude	Longitude
1	8/3/56	Hawaii—Kwajalein	150	25 N	170 W
2	7/24	Guam—Palau	35	9 N	138 E
3	7/25	Japan—Saipan	90	15 N	145 E
4	7/13	Guam—Yap—Guam	35	9 N	138 E
5	8/13	Hawaii—Guam	95	19 N	165 E
6	7/27	Hawaii—Kwajalein	720	10 N	162 E
7	8/7	Kwajalein—Manila	300	10 N	157 E
			300	13 N	140 E
8	8/7	Hawaii—Guam	40	17 N	155 E
9	8/30	Guam—Manila	50	13 N	141 E
10	8/12	Manila—Japan	25	18 N	117 E
11	9/9	Guam—Kwajalein	1100	12 N	154 E
			500	11 N	162 E
12	8/26	Guam—Wake	85	19 N	166 E
13	9/30	Wake—Hawaii	40	20 N	175 E
14	9/21	Hawaii—Truk	65	10 N	162 E
15	9/20	Guam—Manila	95	11 N	158 E
16	9/25	Hawaii—Japan	20	33 N	163 E
17	9/28	Japan—Guam	30	22 N	143 E
18	10/9	Truk—Guam	80	10 N	150 E
19	9/27/56	Truk—Hawaii—Truk	660	13 N	151 E (9/28)
			1100	12 N	151 E (10/2)
20	9/12	Kwajalein—Hawaii	20	12 N	174 E
21	10/17	Japan—Guam	25	23 N	142 E
22	9/6	Manila—Taiwan	10		
23	10/7	Taiwan—Manila	10		
24	9/24	Japan—Manila	15	26 N	129 E
25	9/6	Japan—Guam	25	30 N	140 E
26	9/16	Johnston—Hawaii	15	20 N	171 W
27	10/22	Hawaii—Kwajalein	20	16 N	173 W
28	10/22	Japan—Guam	25	16 N	144 E
29	10/13	Hawaii—Guam	1900	19 N	165 E
			260	15 N	150 E
30	10/25	Kwajalein—Guam	750	12 N	151 E
31	10/30	Hawaii—Japan	35	35 N	155 E
32	10/25	Guam—Hawaii	680	13 N	146 E
33	10/10	Japan—Manila	30	17 N	131 E
34	11/9	Hawaii—Guam	890	18 N	165 E
			290	14 N	145 E
35	10/23	Hawaii—Manila	930	18 N	163 E
			390	15 N	150 E
36	11/5	Japan—Manila	30	23 N	125 E
37	11/11	Guam—Truk	320	12 N	144 E
			150	8 N	147 E
38	11/16	Japan—Manila	20	21 N	121 E
39	12/12	Japan—Manila	15	18 N	120 E
40	12/2	Guam—Manila	35	14 N	141 E
41	12/18	Japan—Guam	190	16 N	144 E
42	11/16	Manila—Hawaii	110	14 N	145 E
43	1/9/57	Japan—Guam	25	14 N	144 E
44	12/17/56	Japan—Manila	15	27 N	130 E
45	1/17/57	Hawaii—Japan	30	27 N	156 E
46	2/16	Japan—Manila	50	15 N	119 E
47	2/27	Japan—Guam	30	19 N	144 E
48	2/9	Japan—Manila	20	28 N	129 E
49	2/17	Japan—Manila	140	30 N	127 E
			100	17 N	120 E

Table 22 (Continued)

Sample No.	Starting date	Course	Maximum β activity (MFP)		
			Dis/min/liter	Latitude	Longitude
50	3/13/57	Japan-Guam	40	25 N	142 E
51	4/7	Yap-Morotal-Yap	20	11 N	142 E
52	4/27	Guam-Hawaii	30	19 N	168 E
53	4/15	Guam-Manila	25	14 N	139 E
54	4/23	Hawaii-Guam	60	17 N	156 E
55	4/22	Manila-Guam	20	14 N	146 E
56	4/2	Kwajalein-Guam	20	12 N	152 E
57	4/8	Japan-Manila	15	17 N	118 E
58	4/27	Guam-Kwajalein	25	10 N	160 E
59	3/7	Hawaii-Japan	35	31 N	147 E
60	4/29	Japan-Manila	490	25 N	128 E
			550	19 N	121 E
61	5/6	Japan-Guam	45	16 N	146 E
62	5/8	Kwajalein-Guam	35	12 N	175 E
63	3/26	Manila-Japan	35	20 N	121 E
64	5/4	Hawaii-Japan	35	21 N	162 E
65	5/12	Guam-Manila	35	13 N	121 E
65A	4/22	Guam-Equator-Ponape	170	5 N	157 E
65B	5/25	Japan-Manila	16	20 N	121 E
65C	5/4	Kwajalein-Hawaii	15	11 N	173 E
65D	5/30	Hawaii-Wake	25	19 N	167 E
65E	5/26	Guam-Truk	250	7 N	153 E
65F	3/26	Guam-Truk	31	9 N	145 E
65G	6/4	Truk-Guam	35	11 N	147 E
65H	5/25	Hawaii-Manila	18	17 N	156 E
65I	5/30	Hawaii-Guam	27	18 N	166 E
65J	6/5	Wake-Guam-Wake	1	16 N	153 E
65K	6/8	Japan-Guam	16	19 N	144 E
65L	6/23	Hawaii-Guam	23	15 N	149 E
65M	6/5	Manila-Guam	34	14 N	134 E
65N	7/4	Guam-Hawaii	22	16 N	152 E
65O	7/2	Manila-Guam	33	14 N	139 E
65P	7/9	Japan-Guam	31	25 N	142 E
65Q	6/28	Hawaii-Japan	23	31 N	165 E
66	6/14	Palou-Guam	22	16 N	143 E
66A	7/11	Truk-Guam	51	9 N	144 E
67	7/25	Hawaii-Guam	22	16 N	153 E
68	7/24	Guam-Palau	21	9 N	138 E
69	7/29	Guam-Hawaii	23	18 N	152 E
70	8/2	Japan-Manila	15	29 N	132 E
71	8/3	Guam-Equator-Truk	Not Run		
72	8/23	Japan-Guam	27	20 N	143 E
73	8/25	Hawaii-Japan	186	36 N	145 E
74	8/27	Guam-Truk	24	8 N	150 E
75	8/27	Japan-Guam	18	28 N	142 E
76	9/7	Hawaii-Guam	22	10 N	159 E
77	9/14	Guam-Kwajalein	27	9 N	165 E
78	9/10	Guam-Equator-Truk	Not Run		
79	10/12	Truk-Guam	14	10 N	139 E
80	11/14	Guam-Kwajalein	27	7 N	155 E
81	11/27	Guam-Palau	32	10 N	141 E
82	2/11	Guam-Truk	23	10 N	148 E
83	3/4	Guam-Truk-Guam	21	10 N	148 E
84	3/12	Guam-Palau	17	10 N	142 E

4. UPTAKE OF Sr^{90} AND Cs^{137}

4.1 MILK

The comparison of strontium to calcium uptake led to the study of dietary calcium sources for the population. In the United States and, in fact, in most of the temperate countries, milk is a major source of body calcium. This is particularly true during childhood, which is the period of direct skeletal formation, as contrasted to the situation during adult life when calcium turnover is the principal phenomenon, with little or no increase in total bone.

Monitoring of Sr^{90} in milk was begun at HASL early in 1954, although individual samples had been analyzed there and elsewhere somewhat earlier. The entire program in the United States and other countries presently includes analysis of milk from about 100 locations and is the largest monitoring program in the study of uptake.

In the case of Sr^{90} , although milk has been selected as a monitoring tool, it is not the only source of this isotope. The levels of Sr^{90} with respect to calcium are even higher in many vegetables, and the milk source may be most important only in the case of growing children.

HASL began analyses of powdered and liquid milk early in 1954. Analysis of the liquid samples was resumed when it was discovered that the powdered milk was not representative of the New York City milkshed.

The liquid milk samples are obtained by daily local purchases of 1-qt samples representing major dairies in rotation. These are pooled to give a monthly sample for analysis. The data are reported in Table 23, and the results are plotted in Fig. 9.

Weekly powdered milk samples are collected at Perry, N. Y., and these are composited to give monthly samples. These data are reported in Table 24, and the results are plotted in Fig. 10.

Other sources of powdered milk have been tested but only Mandan, N. Dak., and Columbus, Wisc., have been able to supply samples on a continuing basis. The data are shown in Table 25 with the Mandan and Columbus results being plotted in Figs. 11 and 12, respectively.

Samples of powdered milk have also been received intermittently from Japan and the United Kingdom. At the present time the samples from the United Kingdom are being analyzed in their laboratories, and HASL receives samples for cross-checking purposes only. Japanese milk is obtained when available. The data on samples from these two countries are reported in Table 26.

a. *USPHS Survey.* The USPHS has conducted a pilot study on the radioactivity in milk in five geographic areas. These were the milksheds serving Sacramento, Salt Lake City, St. Louis, Cincinnati, and New York City. The Sr^{90} data are reported in Table 27. In addition, measurements were made on other isotopes: specifically, I^{131} , Sr^{89} , Ba^{140} , and Cs^{137} .

The USPHS is continuing the analysis of milk and is expanding its network; additional sampling points are being established in the milksheds serving Atlanta, Ga.; Fargo, N. Dak., and Moorhead, Minn.; Austin, Texas; and Spokane, Wash., and a milkshed in southern Wisconsin. This expansion will provide even wider geographic coverage.

In order to make these studies, a monthly 1-gal composite sample is collected at a designated point in each of the five milksheds. The collection is arranged through the cooperation of State and municipal health agencies and the dairy industry.

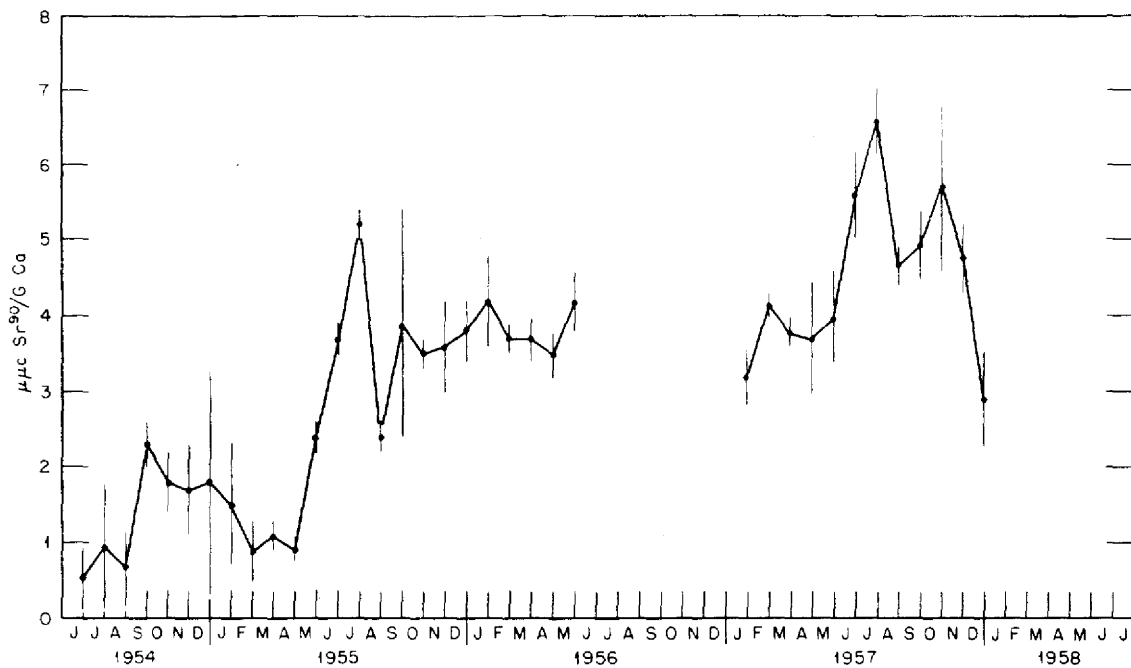

Fig. 9—Monthly Sr⁹⁰ levels in New York City liquid milk.

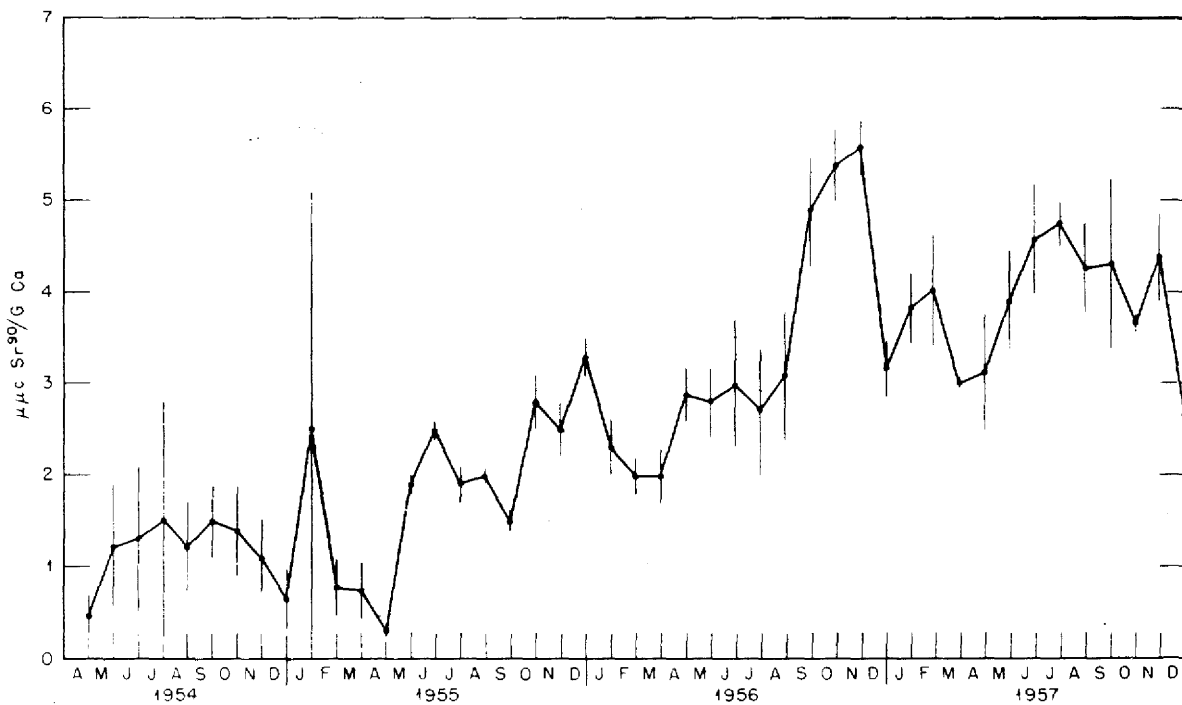

Fig. 10—Monthly Sr⁹⁰ levels in Perry, N. Y., powdered milk.

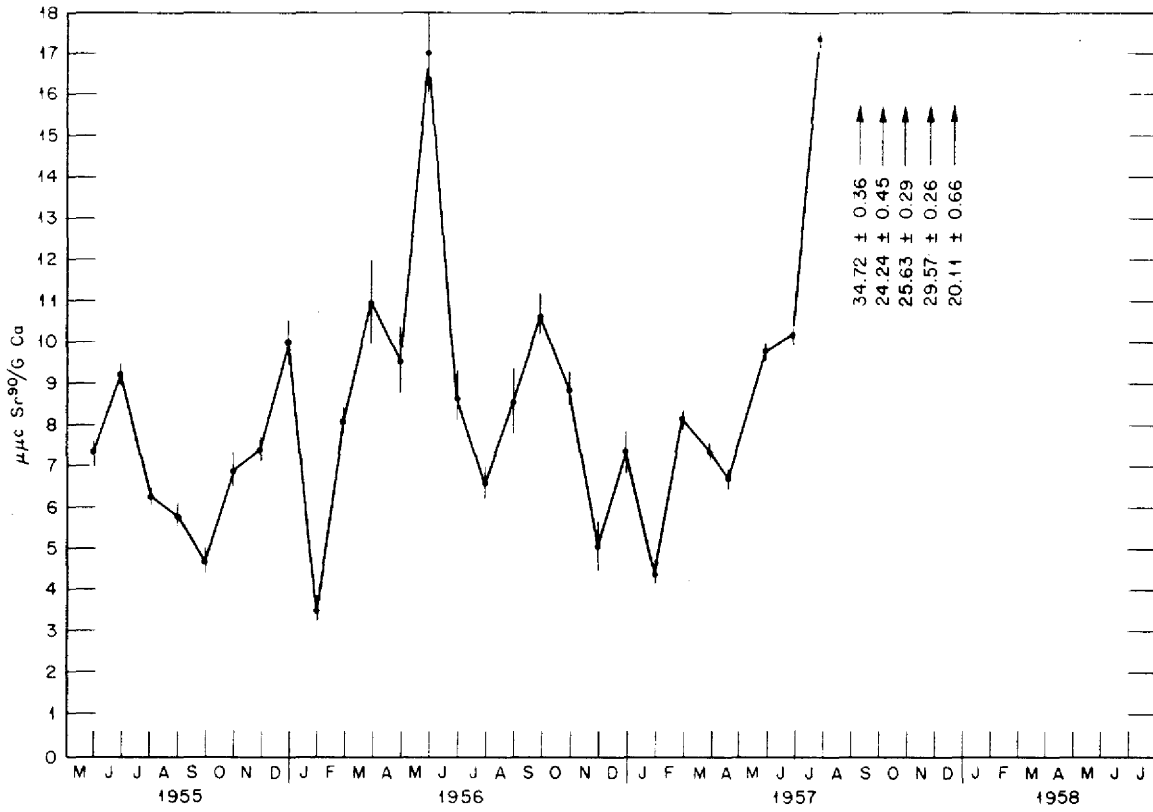

Fig. 11—Monthly Sr⁹⁰ levels in Mandan, N. Dak., powdered milk.

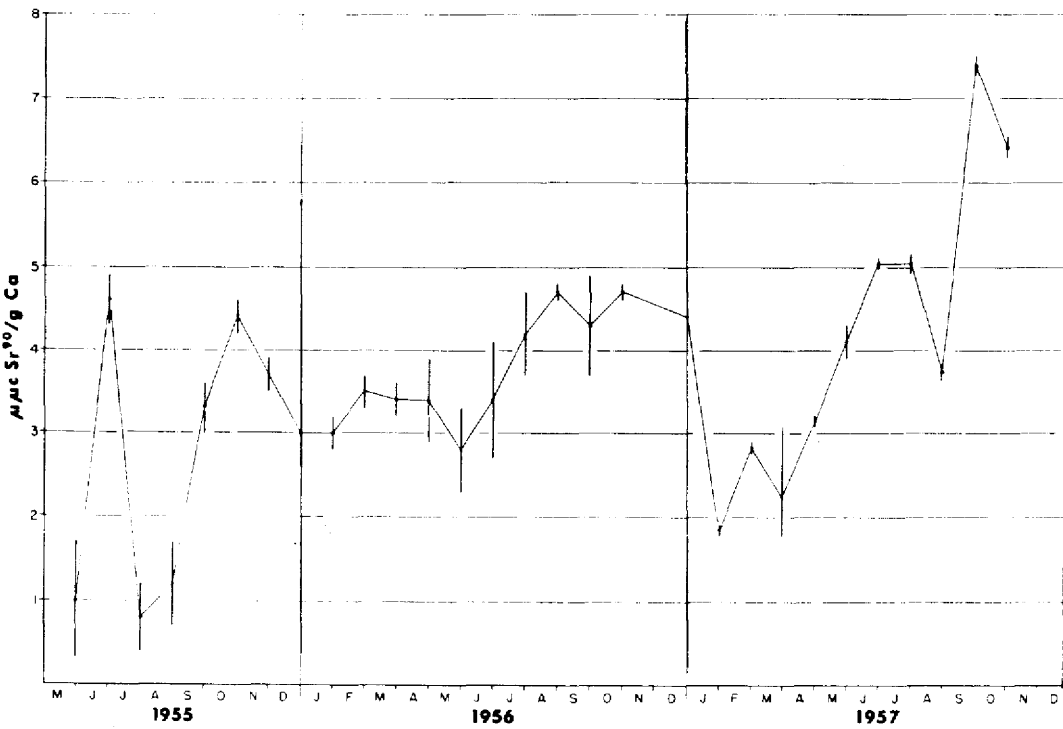

Fig. 12—Monthly Sr⁹⁰ levels in Columbus, Wisc., powdered milk.

b. *Analyses at the University of Chicago and Lamont Geological Observatory.* The University of Chicago carried out a monitoring program for liquid milk in the Chicago area to determine local variability. These results are reported in Table 28.

The Lamont Geological Observatory has measured a number of samples, reported in Table 29. They are expanding their milk analysis program to include determination of Sr^{90} on a large number of the samples collected for Cs^{137} analysis at the Los Alamos Scientific Laboratory (LASL). These data are not yet available.

c. *Sr^{90} Analyses in Other Countries.* The United Kingdom has a network of milk sampling stations for which the data are reported in Part 4 of this report. Their results are quite comparable to those in the New York City area, and extensive cross-checks between the Harwell group and HASL have shown that the measurements are also directly comparable.

The network of milk sampling stations in Canada shows activities that are somewhat higher than those in the New York area and are more comparable to the results from North Dakota. Their data for 1957 are not yet available, but they have been presented to the United Nations Scientific Committee on the Effects of Atomic Radiation.

d. *Cs^{137} Determinations in Milk.* LASL has been making measurements of the Cs^{137} content of milk since 1956. These data are presented here through the courtesy of Dr. E. C. Anderson.

The measurements are performed on 50-lb samples using the Los Alamos large liquid scintillation whole-body counter. Results are reported in terms of the gamma ratio of Cs^{137} to K^{40} . The latter number is quite constant in milk and serves as a useful reference point.

The 1956 data are reported in Table 31a, the 1957-1958 data are reported in Table 31b, and the foreign milk samples analyzed are reported in Table 31c.

4.2 OTHER FOOD AND HERBAGE

A number of samples of foods other than milk and samples of miscellaneous herbage have been analyzed in the general strontium program. These samples were directed toward studies of uptake, but again it should be noted that they were not part of a controlled experiment but were the result of surveys.

These samples do indicate general levels in foodstuffs and certain types of animal fodder during the period of sampling.

a. *Sr^{90} in Canned Fish.* A series of samples of canned fish has been run at HASL. Samples from the eastern and western Pacific fishing areas were forwarded to HASL each month by Star-Kist Foods, Inc., and samples of bonito and Alaska pink salmon were purchased in local stores.

The collections were carried on from April 1956 through August 1957. The data are reported in Table 32. The series was discontinued temporarily since there seemed to be no trend in time or location. Sampling will be resumed in the fall of 1958.

b. *Sr^{90} in Food Samples Collected at Ithaca, N. Y., and Brawley, Calif.* A series of samples has been taken at Brawley, Calif. This is a region of low rainfall, and the water supply for growing vegetables is almost completely by irrigation. Because of the low rainfall, it was expected that there would be low fallout and, therefore, low concentration of Sr^{90} in the foods. This is definitely true as indicated by comparison with data from Ithaca, N. Y., which is included in Table 33, and with the data from the Lamont Geological Observatory in Table 34.

c. *Sr^{90} in Food Samples Collected by the Lamont Geological Observatory.* A group of food samples was collected in 1956 and in 1957 by the Lamont Geological Observatory. The results of their analyses are given in Table 34. There is no obvious pattern to the data with respect to calcium content, whether the vegetable is a root or leafy type, or to the area of sampling.

d. *Sr^{90} in Cheese.* The sampling of either liquid or dried milk is not always possible in every area of interest. Cheese is a possible solid substitute for a milk sample and is the most likely source of milk intake for large segments of the world population.

The processing of the many types of cheeses produced in the world will cause some considerable variation in the actual concentration of Sr^{90} per unit weight of cheese. It is necessary

that this be considered as well as the value in terms of micromicrocuries of Sr^{90} per gram of calcium, since a high value for the latter is less important if the over-all concentration is low.

e. *Diet Sampling Surveys Conducted Outside the United States.* A number of diet surveys are being undertaken throughout the world to study the nutrition of the countries concerned. Some of the samples taken for this purpose have been made available for Sr^{90} analysis. In addition, certain food sampling has been carried out in South America under the direction of Dr. Paul Pearson of the Division of Biology and Medicine, AEC. The results of these analyses are given in Table 38.

f. *Sr^{90} in Miscellaneous Vegetation and Herbage.* The results of a number of miscellaneous samples of vegetation and herbage are given in Table 39. These data are reported for completeness and are not directly connected with any of the monitoring or experimental programs.

4.3 Sr^{90} IN URINE

Urine sampling is a technique widely used in the field of industrial hygiene to measure exposure of workers to toxic materials. The variation in excretion rates among individuals exposed to the same level, however, makes the urine results very difficult to interpret. Colonel James Hartgering of the Walter Reed Army Hospital reported a series of results at the Congressional Hearings in 1957. A few other data are given in Table 40.

4.4 BONE

In following calcium through metabolic processes, Sr^{90} shows highest concentration in bone when compared to other tissue. The various factors in the uptake of Sr^{90} and the Sr/Ca discrimination are being studied. In addition, it is desirable to have a monitoring program to follow the concentrations of Sr^{90} in various bone materials as a function of time.

Measurements have been carried out on both animal bone and human bone. Animal bone invariably shows high Sr^{90} concentrations when compared to human bone from the same area. One factor causing this higher concentration is the amount of Sr^{90} deposited on leaf surfaces. This leaf deposit is eaten by the animal, whereas a large portion of the human diet consists of foods of animal origin, which contain lower concentrations of Sr^{90} , and well-washed and otherwise prepared vegetables.

a. *Sr^{90} in Miscellaneous Animal Bone.* In addition to certain specific studies of animal bone (see Secs. 5.1 and 5.5), there have been a number of miscellaneous animal bone samples analyzed. These are tabulated according to the laboratory responsible for the analyses, but they are not otherwise grouped.

Table 41 gives the HASL data; Table 42 gives the data from the University of Chicago, and Table 43 gives the data from the Lamont Geological Observatory.

The levels in the samples reported here may be compared with those reported by the United Kingdom, which are presented in Part 4 of this report.

b. *Sr^{90} in Human Bone.* The largest group of data on the Sr^{90} content of human bone is that reported by Dr. Kulp of the Lamont Geological Observatory.^{1,2} These data have been summarized in the articles cited, but a brief summary is reproduced here in Table 44 and Fig. 13.

A number of samples were analyzed at the University of Chicago, and the results are summarized in Tables 45 and 46. The first table includes infants from the Chicago area, and the second table summarizes the results on infants from other localities.

The level of Sr^{90} in human bone lags considerably behind the level in the environment. In other words, man is generally not yet in equilibrium with his environment. The highest Sr^{90} values should be found in children that have lived their lives in the period of greatest contamination, i.e., children born in late 1954 or afterward. This is generally reflected in the data presented for the United States as well as for other countries such as the United Kingdom. (See Part 4 of this report.)

Adult bone indicates only the turnover of skeletal calcium and contains Sr^{90} at a relatively low level at the present time. When the children who were born since 1954 become adults, the

Sr^{90} content of their bones will be higher than present-day adults, because their skeletons will reflect the contamination levels that have existed throughout their entire lifetime.

It should be noted also that the bones of stillborn infants, or those that die at a very early age, contain only the amount of Sr^{90} that is supplied by the mother through the placenta. Examination of the data reveals that the Sr^{90} level in the skeleton of stillborns is lower than that in the bones of children aged 1 to 5, for example. It seems evident that the Sr^{90} level in skeletons of stillborn children should not be considered as a reliable index of the uptake from the contaminated environment.

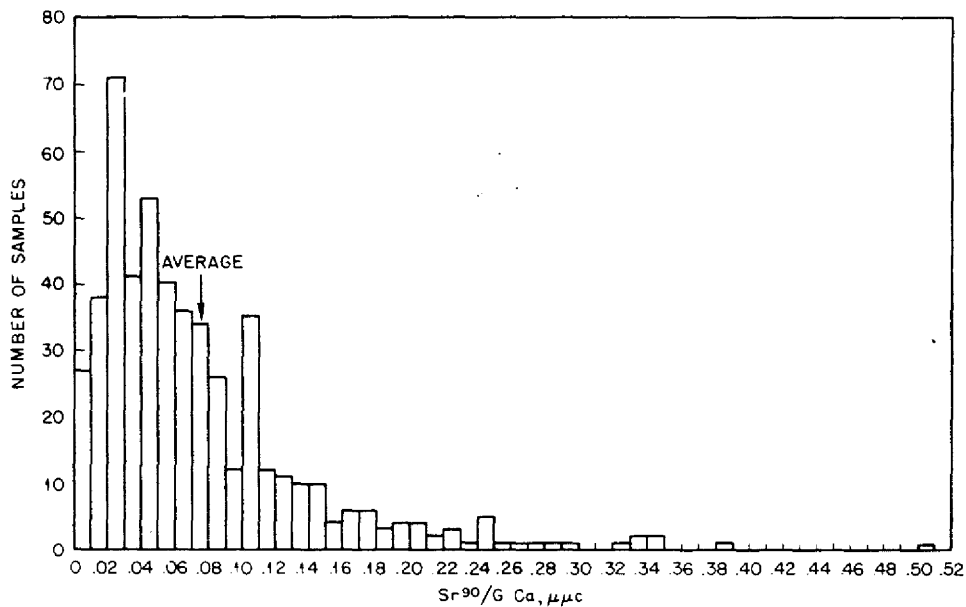

(a)

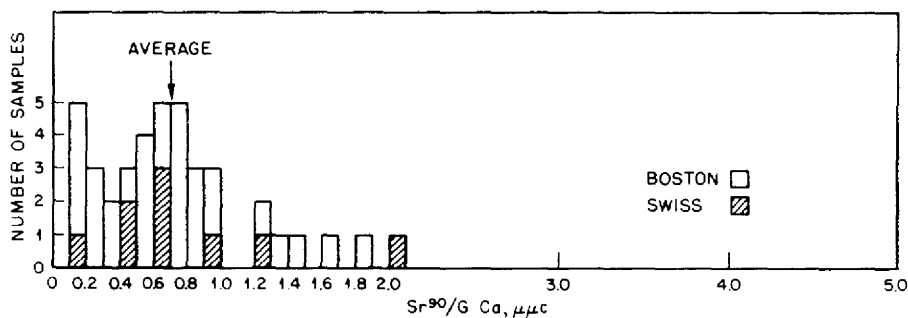

(b)

Fig. 13—Histogram of Sr^{90} concentration in bones. a. Adult bones, representing world, 1955–1956. b. Bones from children, 1956.

c. Sr^{90} in Teeth. It would be desirable to use human teeth as a substitute for bone samples, particularly for younger children from whom deciduous teeth are readily available. Some work has been done on the analysis of teeth, but more data are required before a decision can be made that teeth are a satisfactory substitute.

The available results are shown in Table 47.

4.5 WHOLE-BODY MEASUREMENTS OF Cs^{137}

It is possible to measure the Cs^{137} content of the human body *in vivo*. The Cs^{137} level in man is the resultant of several portions of his diet, including milk, meat, vegetables, and possibly drinking water, and should be relatively stable over short periods of time.

The majority of data reported have been obtained at LASL or at the Argonne National Laboratory (ANL). In the first case, a large liquid scintillation counter is used, and at ANL a large sodium-iodide crystal is the detector. The liquid scintillation system is more rapid, but the sodium-iodide crystal apparently has a better energy resolution.

The data from LASL are reported in Tables 48a through 48d. Control subjects were run at both laboratories to show time trends, whereas the general samples run at LASL were mostly visitors to the Laboratory.

Data from ANL are reported in Table 49.

a. *LASL Whole-body Measurements.* The LASL measurements were carried out on a number of control subjects during 1956 (Table 48a) and 1957 (Table 48c). Control subjects show the time trend of the human Cs^{137} burden at the particular location of the laboratory. The indicated ratios in all cases are less than 1, indicating that the gamma dose from cesium is only a fraction of that delivered by potassium.

It has been customary at the laboratory that all visitors to the Biomedical Research Group are measured in the whole-body counter. This has given a large number of results on individuals from other states and other countries.

The data have been summarized in journal articles,^{3,4} and the conclusions drawn in these articles will not be repeated here. On the other hand, the articles could only summarize the entire mass of data, and it was felt that this detailed material should be available.

b. *ANL Whole-body Measurements.* The large crystal spectrometer at ANL has been used for whole-body measurements on a series of control subjects since 1955. These data are shown in the figure shown with Table 49. They have concluded that the average Cs^{137} body burdens have remained essentially constant since the spring of 1956, with the exception of minor fluctuations due to dietary changes.

REFERENCES

1. J. L. Kulp, et al., Strontium-90 in Man, *Science* 125: 219 (1957).
2. W. R. Eckelmann, et al., Strontium-90 in Man—II, *Science* 127: 266 (1958).
3. E. C. Anderson, et al., Radioactivity of People and Foods, *Science*, 125: 1273-1278 (1957).
4. E. C. Anderson, World-wide Distribution of Cs-137, (to be published).

Table 23—MONTHLY RADIOSTRONTIUM LEVELS IN LIQUID MILK FROM NEW YORK CITY

Sampling month	1954	1955	1956	1957	1957
	Sr ⁹⁰ , μμc/g Ca	Sr ⁹⁰ , μμc/g Ca	Sr ⁹⁰ , μμc/g Ca	Sr ⁹⁰ , μμc/g Ca	Sr ⁸⁹ /Sr ⁹⁰ *
January		1.5 ± 0.8	4.2 ± 0.6	3.19 ± 0.36	7.4
February		0.9 ± 0.4	3.7 ± 0.2	4.14 ± 0.12	
March		1.1 ± 0.2	3.7 ± 0.3	3.78 ± 0.18	
April		0.9 ± 0.15	3.5 ± 0.3	3.71 ± 0.73	0.96 ± 0.50
May		2.4 ± 0.2	4.2 ± 0.4	3.98 ± 0.61	3.0 ± 0.9
June	0.52 ± 0.41	3.7 ± 0.2		5.56 ± 0.56	4.5 ± 0.9
July	0.93 ± 0.82	5.2 ± 0.2		6.56 ± 0.45	16.5 ± 1.4
August	0.64 ± 0.50	2.4 ± 0.2		4.63 ± 0.26	15.8 ± 2.3
September	2.3 ± 0.3	3.9 ± 1.5		4.90 ± 0.45	15.8 ± 2.9
October	1.8 ± 0.4	3.5 ± 0.2		5.71 ± 1.14	32.3 ± 5.3
November	1.7 ± 0.6	3.6 ± 0.6		4.73 ± 0.45	12.7 ± 1.7
December	1.8 ± 1.5	3.8 ± 0.4		2.89 ± 0.63	9.8 ± 3.2

*Extrapolated to the midpoint of the sampling period.

Table 24—MONTHLY RADIOSTRONTIUM LEVELS IN POWDERED MILK FROM PERRY, NEW YORK

Sampling month	1954	1955	1956	1956	1957	1957
	Sr ⁹⁰ , μμc/g Ca	Sr ⁹⁰ , μμc/g Ca	Sr ⁹⁰ , μμc/g Ca	Sr ⁸⁹ /Sr ⁹⁰ *	Sr ⁹⁰ , μμc/g Ca	Sr ⁸⁹ /Sr ⁹⁰ *
January		2.5 ± 2.6	2.3 ± 0.3		3.83 ± 0.38	2.1
February		0.77 ± 0.31	2.0 ± 0.2		4.02 ± 0.62	2.2
March		0.75 ± 0.31	2.0 ± 0.3		3.00 ± 0.06	
April	0.47 ± 0.22	0.31 ± 0.05	2.9 ± 0.3		3.12 ± 0.65	
May	1.2 ± 0.7	1.9 ± 0.1	2.8 ± 0.4		3.91 ± 0.60	7.2 ± 1.6
June	1.3 ± 0.8	2.5 ± 0.1	3.0 ± 0.7	4	4.59 ± 0.62	7.0 ± 1.5
July	1.5 ± 1.3	1.9 ± 0.2	2.7 ± 0.7	14	4.74 ± 0.25	11.4 ± 0.9
August	1.2 ± 0.5	2.0 ± 0.1	3.1 ± 0.7	13	4.25 ± 0.50	10.0 ± 1.2
September	1.5 ± 0.4	1.5 ± 0.1	4.9 ± 0.6	22	4.30 ± 0.94	22.1 ± 4.7
October	1.4 ± 0.5	2.8 ± 0.3	5.4 ± 0.4		3.65 ± 0.10	21.1 ± 5.2
November	1.1 ± 0.4	2.5 ± 0.3	5.6 ± 0.3		4.38 ± 0.48	4.8 ± 1.1
December	0.64 ± 0.34	3.3 ± 0.2	3.16 ± 0.30	2.8	2.64 ± 1.03	8.0 ± 4.6

*Extrapolated to the midpoint of the sampling period.

Table 25—MONTHLY Sr⁹⁰ LEVELS IN POWDERED MILK FROM OTHER UNITED STATES LOCATIONS
(Results in $\mu\mu\text{c/g Ca}$)

	State College, Miss.	St. Louis, Mo.	Columbus, Wisc.	Mandan, N. Dak.*	Portland, Oreg.
1955 May	2.6 ± 0.2	4.1 ± 0.3	1.0 ± 0.7	7.3 ± 0.3	1.7 ± 0.2
June	4.7 ± 0.2	4.6 ± 0.3	4.6 ± 0.3	9.2 ± 0.2	2.6 ± 0.3
July	4.4 ± 0.2	3.9 ± 0.3	0.8 ± 0.4	6.3 ± 0.2	
August	4.1 ± 0.2		1.2 ± 0.5	5.8 ± 0.3	
September	3.2 ± 0.2		3.3 ± 0.3	4.7 ± 0.3	
October			4.4 ± 0.2	6.9 ± 0.4	
November			3.7 ± 0.2	7.4 ± 0.3	
December			3.0 ± 0.4	10 ± 0.5	
1956			3.0 ± 0.2	3.5 ± 0.2	
			3.5 ± 0.2	8.1 ± 0.3	
			3.4 ± 0.2	11 ± 1.0	
			3.4 ± 0.5	9.6 ± 0.8	5.2 ± 0.3
May	4.9 ± 0.5		2.8 ± 0.5	17 ± 1.0	6.4 ± 0.3
June	4.4 ± 0.5		3.4 ± 0.7	8.7 ± 0.6	5.0 ± 0.5
July	6.1 ± 0.7		4.2 ± 0.5	6.6 ± 0.4	
August	3.8 ± 0.07		4.7 ± 0.1	8.6 ± 0.8	
September	4.8 ± 0.2		4.3 ± 0.6	10.7 ± 0.5	
October			4.7 ± 0.1	8.9 ± 0.4	
November				5.1 ± 0.6	
December			4.4 ± 0.1	7.4 ± 0.5	
1957 January			1.85 ± 0.06	4.4 ± 0.2	
February			2.83 ± 0.07	8.17 ± 0.13	
March			2.24 ± 0.85	7.38 ± 0.14	
April			3.15 ± 0.06	6.75 ± 0.15	
May			4.1 ± 0.2	9.79 ± 0.14	
June			5.04 ± 0.06	10.91 ± 0.16	
July			5.05 ± 0.11	17.33 ± 0.24	
August			3.72 ± 0.10	32.74 ± 0.36	
September			7.38 ± 0.12	24.24 ± 0.45	
October			6.42 ± 0.13	25.63 ± 0.29	
November				29.57 ± 0.26	
December				20.11 ± 0.66	

*Buttermilk.

Table 26—Sr⁹⁰ IN MILK COLLECTED OUTSIDE THE UNITED STATES

Sampling date	Sr ⁹⁰ /g Ca, μμc	Sampling date	Sr ⁹⁰ /g Ca, μμc	Sampling date	Sr ⁹⁰ /g Ca, μμc
Japan		England		Argentina	
1955*		1955		1957	
January	3.0 ± 0.3	4/15	3.0 ± 0.3	November	1.66 ± 0.27
February	1.0 ± 0.2	4/23	2.7 ± 0.2	November	1.36 ± 0.18
March	2.0 ± 0.2	6/5	5.3 ± 0.2	November	1.56 ± 0.26
April	1.8 ± 0.1	6/10	5.4 ± 0.4		
May	1.9 ± 0.2	6/17	6.4 ± 0.4	Chile	
June	0.82 ± 0.21	6/24	5.6 ± 0.2	11/29/57	2.95 ± 0.08
August	0.81 ± 0.24	7/1	5.2 ± 0.4		
September	2.0 ± 1.1	7/15	2.6 ± 0.2	Union of South Africa	
October	4.5 ± 0.3			November	8.93 ± 0.15
November	2.5 ± 0.3			1957	
December	3.5 ± 0.2				
1956		1956			
January	2.7 ± 0.6	1/26	4.0 ± 0.5	India	
3/22	3.5 ± 0.5	2/2	4.6 ± 0.3	Late 1957	2.72 ± 0.08
4/27	3.0 ± 0.1	3/29	4.0 ± 0.5		
7/20	2.26 ± 0.18	4/12	4.6 ± 1.3		
9/18	2.66 ± 0.04	5/3	4.3 ± 0.1		
10/19	3.00 ± 0.05	5/11	4.5 ± 0.5		
		6/1	4.1 ± 0.8		
		6/15	6.0 ± 0.4		
		6/21	5.42 ± 0.35		
		6/29	4.4 ± 0.5		
		7/13	3.87 ± 0.07		
		8/7	4.29 ± 0.09		
		8/23	2.85 ± 0.04		
		10/3	3.36 ± 0.08		
		10/28	2.54 ± 0.05		
		11/16	1.89 ± 0.05		
		12/17	4.79 ± 0.28		
1957		1957			
1/8	1.67 ± 0.03	3/25	4.90 ± 1.10		
July	(Incomplete)	4/7	4.73 ± 0.32		
September	(Incomplete)				

*Month received at HASL; sampling date unknown.

Table 27—PUBLIC HEALTH SERVICE—MILK SAMPLES
(First Year's Average, in micromicrocuries per liter)

	Calcium, g/liter	I ¹³¹	Sr ⁸⁹	Sr ⁹⁰	Ba ¹⁴⁰	Cs ¹³⁷
Sacramento	1.128	35	14.7	3.4	19.5	32.8
Salt Lake City	1.137	274	34.0	3.8	54.0	43.7
St. Louis	1.250	275	78.3	7.4	98.5	40.3
Cincinnati	1.254	132	45.4	5.1	39.2	27.3
New York	1.076	82	42.4	5.8	46.8	29.7

Table 27a—RADIOACTIVITY IN MILK

Collection month	Sr ⁹⁰ /liter, $\mu\mu\text{c}$				
	Sacramento, Calif.	Salt Lake City, Utah	St. Louis, Mo.	Cincinnati, Ohio	New York, N. Y.
1957					
March				10.3	
April	6.5	9.0	6.5	7.9	
May	6.0	7.6	7.2	6.5	8.0
June	5.0	0.8	7.4	3.7	10.8
July	0	5.9	12.8	7.2	12.6
August	0	0	7.4	0.0	5.6
September	2.3	5.6	9.6	4.0	5.5
October	1.7	3.4	7.1	7.7	4.3
November	9.6	3.0	6.0	4.3	2.8
December	3.2	1.2	5.3	5.9	5.0
1958					
January	2.4	2.6	4.2	0.5	4.1
February	2.8	2.3	5.9	3.5	1.2
March	1.5	3.8	8.9	4.7	4.3
April	10.5	5.1	9.0	6.2	1.6

Table 28 — MILK ANALYZED AT THE UNIVERSITY OF CHICAGO

Fresh Milk from Chicago Area

Date of purchase	Sample No.	Sr ⁹⁰ , μc/g Ca	Date of purchase	Sample No.	Sr ⁹⁰ , μc/g Ca
Wanzer Dairy			Borden Dairy		
Mar. 1955	CL 465	1.26 ± 0.05	Mar. 1955	CL 450	1.17 ± 0.04
Apr. 1955	CL 480-P	1.39 ± 0.09	Apr. 1955	CL 479	1.50 ± 0.06
June 1955	CL 674-P	6.45 ± 0.31	May 1955	CL 598-P	1.84 ± 0.09
Aug. 1955	CL 702-P	2.94 ± 0.17	May 1955	CL 672-P	5.15 ± 0.25
Sept. 1955	CL 737	2.0 ± 0.1	July 1955	CL 677-P	4.64 ± 0.22
Oct. 1955	CL 747-P	1.96 ± 0.09	Aug. 1955	CL 701-P	1.82 ± 0.08
Nov. 1955	CL 827-P	2.34 ± 0.11	Sept. 1955	CL 741	1.55 ± 0.04
Dec. 1955	CL 870-P	2.58 ± 0.15	Oct. 1955	CL 748-P	2.34 ± 0.12
Jan. 1956	CL 960	3.2 ± 0.1	Jan. 1956	CL 958	3.12 ± 0.25
Feb. 1956	CL 1014	2.80 ± 0.08	Feb. 1956	CL 1016	3.40 ± 0.14
Mar. 1956	CL 1029-P	2.45 ± 0.13	Mar. 1956	CL 1030-P	2.99 ± 0.29
Apr. 1956	CL 1064-P	2.61 ± 0.16	Apr. 1956	CL 1058-P	3.21 ± 0.18
May 1956	CL 1069-P	2.23 ± 0.13			
Bowman Dairy			Capitol Dairy		
Mar. 1955	CL 449	1.50 ± 0.06	Mar. 1955	CL 451	1.24 ± 0.06
Apr. 1955	CL 478	1.21 ± 0.07			
May 1955	CL 595-P	1.70 ± 0.16	Pure Milk Association:		
June 1955	CL 673-P	3.5 ± 0.2	Apr. 1955	CL 487	1.98 ± 0.10
July 1955	CL 676-P	5.05 ± 0.48	May 1955	CL 597-P	1.56 ± 0.10
Aug. 1955	CL 703-P	2.34 ± 0.19	June 1955	CL 671-P	5.94 ± 0.28
Sept. 1955	CL 736	2.22 ± 0.8	July 1955	CL 678-P	3.40 ± 0.34
Oct. 1955	CL 746-P	1.92 ± 0.10	Sept. 1955	CL 742	1.56 ± 0.03
Nov. 1955	CL 826-P	1.72 ± 0.09	Oct. 1955	CL 749-P	1.47 ± 0.08
Dec. 1955	CL-869-P	2.35 ± 0.15	Nov. 1955	CL 829-P	2.03 ± 0.09
Jan. 1956	CL 959	7.7 ± 0.4	Dec. 1955	CL 875-P	2.68 ± 0.14
Feb. 1956	CL 1015	3.6 ± 0.2	Jan. 1956	CL 967	3.10 ± 0.09
Mar. 1956	CL 1028-P	3.05 ± 0.20	Feb. 1956	CL 1017-P	2.62 ± 0.17
Apr. 1956	CL 1057-P	2.20 ± 0.13	Mar. 1956	CL 1031-P	1.25 ± 0.12
May 1956	CL 1070-P	1.53 ± 0.13	Apr. 1956	CL 1063-P	2.33 ± 0.13

Date	Type	Location	Sample No.	Sr ⁹⁰ , μc/g Ca
Milk from other sections of United States				
1943	Powdered whole	San Francisco	CL 72, 73, 74	0 ± 0.008
Oct. 1953	Dried skim	Logan	CL 78	1.35 ± 0.05
Oct. 1953	Dried skim	Beaver	CL 79	0.91 ± 0.02
Spring 1954	Land O'Lakes dry skim	Wisc. - Minn.	CL 270	0.24 ± 0.03
June 1954	Land O'Lakes	Wisc. - Minn.	CL 397-P	2.02 ± 0.18
Aug. 1954	Land O'Lakes dry skim	Wisc. - Minn.	CL 398	3.06 ± 0.08
May 1954	Powdered	Clinton	CL 342	0.810 ± 0.045
June 1954	Powdered	Clinton	CL 343	1.05 ± 0.03
June 1954	Powdered	Clinton	CL 344	0.97 ± 0.04
June 1954	Powdered	Clinton	CL 345	1.32 ± 0.06
May 1954	Powdered	Janesville	CL 346	0.71 ± 0.04
May 1954	Powdered	Janesville	CL 347	0.88 ± 0.04
May 1954	Powdered	Janesville	CL 348	0.76 ± 0.04
May 1954	Powdered	Janesville	CL 349	0.69 ± 0.04
Sept. 1954	Powdered	Janesville	CL 350	0.93 ± 0.04

Table 28 (Continued)

Date	Type	Location	Sample No.	Sr ⁹⁰ , μμc g Ca
Milk from the Northern Hemisphere				
Jan. 1954	Milk solids	Bogota, Colombia	CL 286	0.11 ± 0.01
Mar. 1954	Powdered skim	Oslo, Norway	CL 171	1.50 ± 0.15
Jan. 1955	Powdered skim	Oslo, Norway	CL 632-P	0.170 ± 0.022
Jan. 1955	Powdered	Oslo, Norway	CL 633-P	1.18 ± 0.10
Feb. 1955	Powdered	France	CL 481-P	1.35 ± 0.09
Feb. 1955	Dry skim	Italy	CL 458	1.09 ± 0.09
Spring 1952	Dried	Kars, Turkey	CL 620-P	0.63 ± 0.07
July 1954	Dried	Kars, Turkey	CL 621-P	3.65 ± 0.28
May 1954	Powdered	Kars, Turkey	CL 679-P	3.53 ± 0.26
May 1955	Powdered	Kars, Turkey	CL 680-P	14.6 ± 0.9
Jan. 1954	Evaporated	Military Farms, Pakistan	CL 287	0.14 ± 0.05
Feb. 1955	Evaporated	Military Farms, Pakistan	CL 675-P	0.39 ± 0.06
June 1954	Powdered	Hokkaido, Japan	CL 590-P	0.84 ± 0.06
Jan. 1955	Powdered	Nagano, Japan	CL 591-P	1.81 ± 0.11
Milk from the Southern Hemisphere				
Spring 1954	Powdered	Lima, Peru	CL 267-P	0.050 ± 0.005
Spring 1954	Powdered	Buenos Aires, Argentina	CL 268-P	0.10 ± 0.01
Spring 1954	Condensed	Buenos Aires, Argentina	CL 269-P	0.29 ± 0.05
Mar. 1954	Powdered	Natal, South Africa	CL 265	0.24 ± 0.03
Aug. 1954	Powdered whole	Natal, South Africa	CL 631-P	0.49 ± 0.05
Feb. 1955	Roller dried full cream powder	Taree, Australia	CL 615-P	2.02 ± 0.09
Jan. 1955	Spray dried full cream powder	Grafton, Australia	CL 616-P	2.21 ± 0.16
Feb. 1955	Condensed	Perth, Australia	CL 670-P	0.77 ± 0.05
Apr. 1954	Whole milk solids	Hamilton, New Zealand	CL 288	0.18 ± 0.01
Feb. 1955	Powdered skim	Waiton, New Zealand	CL 694-P	0.77 ± 0.07
Feb. 1955	Powdered whole	Waiton, New Zealand	CL 693-P	0.70 ± 0.07

Table 29—MILK SAMPLES REPORTED BY THE LAMONT GEOLOGICAL OBSERVATORY

Location	Type	Date	Sr ⁹⁰ /g Ca, $\mu\mu\text{c}$
	Bordens (powered)	5/16/54	0.41 ± 0.04
New York City	powdered	6/14/54	1.29 ± 0.11
Bergen County, N. J.		9/10/57	3.0–7.7 (range)
			5.5 (av.)
New Jersey (other)		October 1957	5.5 (av.)
New York City	Retail*		5.5
Perry, N. Y.*			4.5
Mohawk Valley		9/10/57	6.6 (av.)
North Carolina		August 1957	5.3 (av.)
North Dakota	powdered*		10.0
State College, Miss.	powdered*	1956	6.5
St. Louis, Mo.	powdered*		6.5
Portland, Oreg.	powdered*		7.0
Rockingham County, Va.		October 1957	3.8 (av.)
Columbus, Wisc.	powdered*		5.5

*Estimated from analysis reported by Health and Safety Laboratory, New York Operations Office, AEC, extrapolated to late 1957.

Table 30a—Sr⁹⁰ IN SKIM MILK POWDER (μc/g Ca)

Sample station	Date processed														Average, 1956
	1955				1956										
	Nov.	Dec.	Jan.	Feb.	Mar.	Apr.	May	June	July	Aug.	Sept.	Oct.	Nov.	Dec.	
Moncton, New Brunswick							5.1*	8.5*	9.4*	4.4*	7.1*	6.4*	11.6*	3.4*	7.0
Granby, Quebec	5.1†	2.8*	4.7	3.7	3.5	4.4	5.9	8.2*	6.9	4.4	6.2†	7.1	6.2†	3.1	5.4
Ottawa, Ontario	4.7	5.5	3.7	3.2	6.0	2.3	6.4	4.1	‡	4.7	5.8	3.6	‡	‡	4.4
											4.9§				
London, Ontario	2.6	1.7	2.1	2.0	2.7	1.5	‡	5.0	3.1	4.1	4.4	‡	3.8	4.8	3.4
				2.6§							4.0§				
Edmonton, Alberta	3.7	¶	4.1	3.7	3.1	3.8	3.4	5.6	4.0	3.0	4.4	5.0	4.9	3.2	4.0
Fraser Valley, British Columbia	5.0	7.8	5.3	5.3	4.0	5.8	8.5	10.3	6.4	4.9	5.8	6.6	¶	¶	6.3
	5.8§	4.7§													
Monthly average	4.3	4.1	4.0	3.6	3.9	3.6	5.9	7.0	6.0	4.3	5.5	5.7	6.6	3.6	5.0

*Buttermilk.

†Whole milk.

‡Samples not available.

§Different samples.

¶Analysis incomplete.

Table 30b—Sr⁹⁰ IN SKIM MILK POWDER (μc/g Ca)*

Sample station	Date processed														Average 1956
	1955				1956										
	Nov.	Dec.	Jan.	Feb.	Mar.	Apr.	May	June	July	Aug.	Sept.	Oct.	Nov.	Dec.	
Moncton, New Brunswick							3.0†	33.7†	32.5†	33.2†	58.0†	180.9†	107.0†	21.6†	58.7
Granby, Quebec	8.3‡	14.8†	0.5	1.8	5.9	2.0	12.6	30.0†	32.0	60.7	130.7‡	206.0‡	87.0‡	13.0	48.5
Ottawa, Ontario	2.4	6.4	1.7	5.9	0.5	4.4	34.7	17.9	§	19.6	82.3	91.0	§	§	28.1
											72.5¶				
London, Ontario	3.0	7.0	4.0	1.8	0.1	3.0	§	25.1	17.2	30.0	50.1	§	92.0	30.0	27.5
				2.0¶							93.5¶				
Edmonton, Alberta	3.7	**	3.9	<0.1	2.1	2.5	3.1	51.2	50.7	54.1	57.9	122.0	51.0	22.5	35.1
Fraser Valley, British Columbia	37.6	13.6	6.6	3.0	4.0	26.4	38.7	43.4	32.4	73.0	85.9	196.0	155.0	65.0	60.8
	6.0¶	6.9¶													
Monthly average	7.8	9.6	3.3	2.5	2.5	7.7	18.4	33.6	33.0	45.1	80.3	159.2	98.4	30.4	43.0

* At date processed.

†Buttermilk.

‡Whole milk.

§Samples not available.

¶Different samples.

**Analysis incomplete.

Table 31a—Cs¹³⁷ DETERMINATIONS IN MILK, 1956
(Measured at the Los Alamos Scientific Laboratory)

Coding for 1956 Milk Samples

The columns indicate, in order:

1. Serial number
2. Type of milk (NFDM = non-fat dry milk solids; WDMS = whole dry milk solids; F 1, F 2, F 3 = fresh milk from each of three producers)
4. State where produced
5. K⁴⁰ activity measured in gamma emissions per second
6. K⁴⁰ specific activity measured in gamma rays per second per pound
7. Cs/K gamma ratio
8. Date of measurement

Serial No.	Type	Weight	State	K ⁴⁰ , dis/sec	K ⁴⁰ /lb	Cs/K	Date
101	NFDM	100	Wisc.	2354	23.54	0.461	3/14
102	NFDM	38	Calif.	1009	26.56	0.253	3/16
103	WDMS	12	Calif.	342	28.54	0.630	3/15
104	WDMS	50	Calif.	1338	26.76	0.186	3/15
110	F 1	46	N. Mex.	106	2.30	0.081	5/21
114	F 3	123	N. Mex.	231	1.88	0.188	5/21
131	F 1	315	N. Mex.	669	2.21	0.090	5/24
132	F 2	225	N. Mex.	404	1.79	0.237	5/24
150	F 1	164	N. Mex.	386	2.35	0.500	6/22
156	F 3	252	N. Mex.	572	2.27	0.186	6/28
157	F 1	243	N. Mex.	591	2.43	0.254	6/29
160	F 2	243	N. Mex.	539	2.21	0.213	7/5
161	F 3	243	N. Mex.	534	2.20	0.194	7/11
163	F 1	243	N. Mex.	566	2.33	0.544	7/19
167	F 2	243	N. Mex.	693	2.85	0.631	7/30
168	F 2	243	N. Mex.	700	2.88	0.657	7/31
169	F 3	243	N. Mex.	568	2.34	0.372	7/31
170	F 1	243	N. Mex.	660	2.71	0.387	8/7
171	F 3	243	N. Mex.	552	2.27	0.169	8/8
172	F 2	243	N. Mex.	707	2.91	0.453	8/8
174	NFDS	100	Nebr.	2523	25.23	0.145	6/16
175	F 1	243	N. Mex.	651	2.68	0.147	8/15
176	F 3	243	N. Mex.	562	2.31	0.091	8/20
177	F 2	243	N. Mex.	575	2.36	0.252	8/21
178	F 1	243	N. Mex.	517	2.12	0.164	8/22
179	F 2	243	N. Mex.	586	2.41	0.272	8/22
180	NFDS	50	Wisc.	1317	26.35	0.935	7/20
181	WDMS	50	Wisc.	1058	21.16	0.835	7/20
182	F 3	243	N. Mex.	530	2.18	0.272	8/29
183	F 1	243	N. Mex.	531	2.18	0.214	8/29
184	F 2	243	N. Mex.	576	2.37	0.313	8/30
186	F 3	243	N. Mex.	489	2.01	0.152	8/5
187	F 1	243	N. Mex.	553	2.27	0.213	9/6
188	F 2	243	N. Mex.	566	2.33	0.251	9/7
189	F 1	243	N. Mex.	524	2.15	0.141	9/10
190	F 3	243	N. Mex.	545	2.24	0.179	9/11
191	F 2	243	N. Mex.	487	2.00	0.342	9/12
194	F 1	243	N. Mex.	539	2.22	0.148	9/17
195	F 3	243	N. Mex.	523	2.15	0.115	9/18
196	F 2	238	N. Mex.	538	2.26	0.251	9/18
197	F 1	243	N. Mex.	523	2.15	0.109	9/24
198	F 3	243	N. Mex.	515	2.11	0.216	9/25
199	F 2	243	N. Mex.	542	2.23	0.176	9/26
200	F 1	243	N. Mex.	503	2.07	0.146	10/1

Table 31a (Continued)

Serial No.	Type	Weight	State	K^{40} , dis/sec	K^{40} /lb	Cs/K	Date
202	F 3	243	N. Mex.	516	2.12	0.136	10/2
203	F 2	243	N. Mex.	531	2.18	0.321	10/3
206	F 1	243	N. Mex.	508	2.09	0.155	10/8
208	F 1	243	N. Mex.	540	2.22	0.030	10/10
209	F 2	243	N. Mex.	531	2.18	0.201	10/10
211	F 1	243	N. Mex.	527	2.16	0.175	10/15
212	F 3	243	N. Mex.	537	2.21	0.043	10/16
214	F 2	243	N. Mex.	513	2.11	0.252	10/17
217	F 3	243	N. Mex.	533	2.19	0.198	10/22
218	F 1	243	N. Mex.	496	2.04	0.101	10/23
219	F 2	243	N. Mex.	514	2.11	0.207	10/25
221	F 1	243	N. Mex.	492	2.02	0.140	10/30
222	F 3	243	N. Mex.	507	2.08	0.096	10/31
223	F 2	243	N. Mex.	524	2.15	0.140	11/1
225	NFDS	50	Wisc.	1223	24.46	0.985	7/20
226	NFDS	52	Nebr.	1295	24.67	0.179	6/16
227	F 1	243	N. Mex.	504	2.07	0.092	11/5
228	NFDS	50	Idaho	1193	23.86	0.313	11/5
229	F 3	243	N. Mex.	498	2.04	0.186	11/7
230	F 2	243	N. Mex.	525	2.16	0.194	11/8
231	F 3	243	N. Mex.	497	2.04	0.133	11/14
232	F 1	243	N. Mex.	507	2.08	0.141	11/16
233	F 2	243	N. Mex.	534	2.20	0.205	11/16
234	F 1	243	N. Mex.	501	2.06	0.185	11/19
235	WDMS	50	Colo.	1368	27.37	0.336	10/30
236	NFDS	50	Calif.	1210	24.21	0.083	10/25
237	WDMS	90	N. Y.	1811	20.13	0.213	2/5
238	F 3	243	N. Mex.	517	2.12	0.203	11/20
239	F 1	243	N. Mex.	494	2.03	0.114	11/26
240	NFDS	50	Miss.	1108	22.16	0.243	10/17
241	WDMS	60	N. Y.	1160	19.34	0.259	2/5
242	WDMS	60	N. Y.	1184	19.74	0.231	2/5
243	WDMS	60	N. Y.	1189	19.83	0.258	2/5
244	WDMS	60	N. Y.	1164	19.40	0.257	
245	F 3	243	N. Mex.	521	2.14	0.124	11/27
246	WDMS	20	N. Y.	418	20.90	0.226	11/12
247	F 2	243	N. Mex.	578	2.38	0.211	11/28
248	DM	112	Australia	1976	17.64	0.277	11/1
249	WDMS	56	Australia	852	15.23	0.261	11/1
250	NFDS	56	Australia	1186	21.18	0.333	11/2
251	F 3	243	N. Mex.	529	2.18	0.049	12/4
252	F 1	243	N. Mex.	502	2.06	0.060	12/4
253	NFDM	50	Utah	1180	23.61	0.195	10/
254	NFDS	50	Mo.	1155	23.10	0.378	11/
255	F 2	243	N. Mex.	528	2.17	0.348	12/5
256	WDMS	50	Wisc.	959	19.18	0.641	11/11
257	NFDS	50	Wisc.	1214	24.28	0.594	11/3
258	WDMS	100	Ky.	2306	23.06	0.284	6/2
259	WDMS	100	Ky.	2473	24.73	0.166	7/6
260	WDMS	100	Ky.	2431	24.31	0.162	7/12
261	WDMS	100	Ky.	2398	23.98	0.169	7/15
262	WDMS	100	Ky.	2490	24.90	0.147	7/16
263	WDMS	100	Ky.	2391	23.91	0.202	7/21
264	WDMS	100	Ky.	2380	23.80	0.212	7/25
265	WDMS	100	Ky.	2396	23.96	0.217	7/31
266	WDMS	100	Ky.	2528	25.28	0.159	8/13
267	WDMS	100	Ky.	2482	24.82	0.141	8/20
268	WDMS	100	Ky.	2528	25.28	0.129	9/1

Table 31b (Continued)

Serial No.	Sub- ject code	Date	Potassium γ dis/sec/lb	γ ratio, Cs/K	Serial No.	Sub- ject code	Date	Potassium γ dis/sec/lb	γ ratio, Cs/K
2200032950	3130	3/15/57	24.784	0.1808	2200147569	3130	3/27/58	26.158	0.3500
2200035650	3130	3/22/57	24.636	0.2140	2200150769	3130	4/4/58	35.696	0.5335
2200037350	3130	3/28/57	24.820	0.2532					
2200040350	3130	4/5/57	23.568	0.2763			Newman, Calif.		
2200041950	3130	4/10/57	24.498	0.2088	2200029750	3130	1/3/57	25.244	0.1080
2200043250	3130	4/18/57	24.616	0.1869	2200031850	3130	3/11/57	24.240	0.1114
2200046150	3130	4/25/57	24.040	0.2656	2200040250	3130	4/5/57	24.454	0.2537
2200048450	3130	5/2/57	24.520	0.1927	2200049150	3130	5/6/57	26.978	0.3748
2200050050	3130	5/9/57	26.052	0.3256	2200058550	3130	6/6/57	23.824	0.3261
2200053150	3130	5/16/57	25.242	0.2937	2200068350	3130	7/8/57	25.738	0.2491
2200054950	3130	5/23/57	24.594	0.3090	2200078450	3130	8/5/57	25.250	0.1541
2200056550	3130	5/31/57	24.212	0.4610	2200086150	3130	9/9/57	25.286	0.1447
2200059050	3130	6/7/57	25.410	0.3034	2200093150	3130	10/3/57	24.164	0.2359
2200060450	3130	6/13/57	30.352	0.6079	2200103750	3130	11/7/57	44.630	0.5065
2200064750	3130	6/26/57	26.790	0.3661	2200113550	3130	12/9/57	24.454	0.0734
2200065450	3130	7/1/57	26.462	0.3409	2200122650	3130	1/9/58	24.804	0.1254
2200067150	3130	7/5/57	25.042	0.2985	2200130250	3130	2/6/58	23.878	0.1272
2200069350	3130	7/12/57	25.690	0.1688	2200140255	3130	3/7/58	24.592	0.1613
2200071450	3130	7/21/57	26.112	0.1810	2200142455	3130	3/14/58	24.206	0.1459
2200073150	3130	7/25/57	25.066	0.1554	2200144655	3130	3/21/58	24.748	0.2638
2200075250	3130	8/2/57	25.208	0.1087	2200147355	3130	3/27/58	24.724	0.3181
2200077550	3130	8/7/57	24.820	0.1417					
2200082650	3130	8/23/57	25.266	0.1575			Tipton, Calif.		
2200083050	3130	8/26/57	24.888	0.1099	2200033550	3130	3/18/57	25.558	0.1046
2200085350	3130	9/9/57	24.008	0.1598	2200036650	3130	3/26/57	25.676	0.1642
2200085850	3130	9/4/57	25.284	0.1189	2200038150	3130	4/1/57	25.427	0.1157
2200086450	3130	9/13/57	24.946	0.1122	2200041250	3130	4/8/57	24.804	0.1512
2200089150	3130	9/19/57	24.582	0.0957	2200042650	3130	4/15/57	26.226	0.1646
2200091850	3130	9/27/57	24.308	0.1744	2200044250	3130	4/22/57	25.878	0.2317
2200093250	3130	10/4/57	24.408	0.0950	2200047850	3130	4/29/57	24.052	0.1459
2200094950	3130	10/10/57	25.062	0.0974	2200049250	3130	5/6/57	25.626	0.1740
2200097750	3130	10/17/57	25.388	0.1247	2200052550	3130	5/13/57	25.628	0.1711
2200100050	3130	10/28/57	26.206	0.1101	2200054050	3130	5/20/57	26.056	0.1790
2200101350	3130	11/1/57	24.168	0.0942	2200055550	3130	5/27/57	26.754	0.1465
2200103650	3130	11/8/57	24.594	0.1884	2200056750	3130	5/31/57	26.388	0.2095
2200106250	3130	11/15/57	24.354	0.1940	2200059350	3130	6/10/57	25.682	0.2197
2200109050	3130	11/26/57	24.150	0.1670	2200061050	3130	6/17/57	25.736	0.3021
2200110850	3130	12/5/57	24.416	0.1496	2200063950	3130	6/24/57	27.758	0.2249
2200111250	3130	11/29/57	23.818	0.2785	2200065550	3130	7/1/57	27.200	0.3138
2200113850	3130	12/13/57	24.118	0.1236	2200068450	3130	7/8/57	27.284	0.2289
2200116150	3130	12/19/57	24.822	0.1027	2200070050	3130	7/15/57	26.940	0.1899
2200118950	3130	12/27/57	24.190	0.1514	2200072050	3130	7/21/57	26.256	0.1273
2200121250	3130	1/3/58	24.304	0.1797	2200073550	3130	7/28/57	25.732	0.1471
2200122750	3130	1/9/58	24.252	0.1601	2200078250	3130	8/5/57	25.376	0.2491
2200125150	3130	1/17/58	24.788	0.1479	2200079750	3130	8/19/57	26.568	0.0870
2200128050	3130	1/24/58	24.232	0.1438	2200080950	3130	8/12/57	26.930	0.1640
2200131050	3130	2/3/58	24.042	0.1720	2200082550	3130	8/23/57	26.712	0.0991
2200133650	3130	2/21/58	24.096	0.1436	2200084050	3130	8/30/57	26.400	0.0436
2200133850	3130	2/13/58	24.490	0.1487	2200085650	3130	9/9/57	26.972	0.0782
2200135250	3130	2/6/58	24.368	0.1389	2200088850	3130	9/13/57	25.874	0.0230
2200139169	3130	2/28/58	24.530	0.1624	2200089950	3130	9/19/57	25.930	0.0583
2200139969	3130	3/7/58	24.202	0.1474	2200091450	3130	9/30/57	25.766	0.1435
2200142169	3130	3/13/58	24.750	0.1872	2200094350	3130	10/7/57	25.438	0.0819
2200144469	3130	3/21/58	24.202	0.3505					

Table 31b (Continued)

Serial No.	Sub- ject code	Date	Potassium γ dis/sec/lb	γ ratio, Cs/K	Serial No.	Sub- ject code	Date	Potassium γ dis/sec/lb	γ ratio, Cs/K
2200095850	3130	10/14/57	26.100	0.0733	2200089550	3130	9/9/57	22.773	0.0534
2200098350	3130	10/21/57	26.324	0.0803	2200090750	3130	9/24/57	34.508	1.0349
2200100150	3130	10/28/57	25.620	0.0799	2200092550	3130	9/30/57	36.828	0.6133
2200101550	3130	11/4/57	25.574	0.0881	2200093750	9410	10/7/57	31.930	0.4073
2200104850	3130	11/12/57	24.842	0.1218	2200095950	3130	10/14/57	27.642	0.2731
2200106150	3130	11/15/57	25.226	0.1246	2200098150	3130	10/21/57	27.332	0.2736
2200108850	3130	11/26/57	25.482	0.0672	2200100650	3130	10/28/57	23.482	0.2480
2200112150	3130	11/29/57	24.886	0.0757	2200102450	3130	11/6/57	25.574	0.2855
2200112750	3130	12/9/57	25.070	0.0508	2200104650	3130	11/12/57	23.909	0.2219
2200113750	3130	12/16/57	26.040	0.0763	2200108350	3130	11/18/57	22.935	0.2260
2200116450	3130	12/20/57	24.934	0.0614	2200109150	3130	11/26/57	23.181	0.1560
2200118850	3130	12/26/57	25.106	0.0798	2200110150	3130	12/2/57	20.755	0.2416
2200120650	3130	1/2/58	24.972	0.1080	2200113650	3130	12/9/57	22.480	0.2312
2200124050	3130	1/13/58	24.924	0.0962	2200114150	3130	12/16/57	23.219	0.0950
2200127550	3130	1/22/58	24.988	0.0909	2200117050	3130	12/20/57	22.909	0.2180
2200128350	3130	1/27/58	25.036	0.0954	2200120050	3130	1/2/58	24.422	0.2379
2200131650	3130	1/31/58	24.796	0.1151	2200123650	3130	1/13/58	23.277	0.1824
2200133150	3130	2/14/58	22.394	0.0699	2200124850	3130	1/9/58	23.622	0.2180
2200134250	3130	2/10/58	25.048	0.0961	2200126050	3130	1/21/58	23.701	0.0892
2200135950	3130	2/24/58	25.112	0.1047	2200128750	3130	1/27/58	23.392	0.8803
2200140139	3130	3/6/58	25.942	0.1068	2200129750	3130	2/3/58	23.011	0.8005
2200141539	3130	3/10/58	25.850	0.0994	2200133350	3130	2/10/58	22.587	0.0808
2200143439	3130	3/17/58	25.098	0.1176	2200135350	3130	2/14/58	22.965	0.0747
2200146239	3130	3/24/58	25.406	0.1456	2200137750	3130	2/24/58	23.438	0.2490
2200147939	3130	3/31/58	25.172	0.1580	2200139066	3130	2/28/58	24.123	0.2661
2200150039	3130	4/7/58	23.880	0.1731	2200140566	3130	3/10/58	24.380	0.2386
Willows, Calif.					2200143166	3130	3/17/58	23.501	0.0833
2200033150	3130	3/14/57	24.525	0.2124	2200145966	3130	3/24/58	23.653	0.1118
2200034650	3130	3/20/57	24.428	0.2375	2200148266	3130	3/31/58	23.234	0.0984
2200037850	3130	3/26/57	23.522	0.2848	2200149966	3130	4/7/58	66.656	0.6516
2200040550	3130	4/5/57	23.569	0.2793	Columbus, Ga.				
2200044350	3130	4/15/57	23.173	0.3590	2200033350	7100	3/18/57	23.866	0.2203
2200045050	3130	4/23/57	24.927	0.2896	2200053950	7100	5/20/57	25.283	0.5439
2200047550	3130	4/29/57	23.483	0.2867	2200062750	7100	6/20/57	26.923	0.4327
2200049550	3130	5/6/57	25.874	0.3238	2200074050	7100	7/30/57	23.977	0.2843
2200052750	3130	5/13/57	23.946	0.3220	2200080650	7100	8/15/57	23.823	0.2931
2200053650	3130	5/20/57	25.207	0.3954	2200105150	7100	11/12/57	23.790	0.5056
2200055350	3130	5/27/57	22.951	0.3135	2200115150	7100	12/17/57	24.480	0.4905
2200056650	3130	5/31/57	23.863	0.3483	2200123750	7100	1/13/58	24.568	0.5205
2200059150	3130	6/10/57	50.902	0.7664	2200136250	7100	2/17/58	24.238	0.5269
2200060950	3130	6/17/57	38.560	0.5451	2200142500	7100	3/14/58	25.313	0.6510
2200064450	3130	6/24/57	29.420	0.3860	Idaho Falls, Idaho				
2200065950	3130	7/1/57	25.843	0.3617	2200031950	9410	3/11/57	24.164	0.2339
2200067750	3130	7/8/57	24.392	0.9796	2200034150	9410	3/19/57	23.144	0.2656
2200069850	3130	7/15/57	25.143	0.1997	2200036250	9410	3/25/57	24.002	0.3254
2200071650	3130	7/21/57	24.455	0.1550	2200037550	9410	3/29/57	23.710	0.2485
2200073750	3130	7/29/57	23.854	0.1651	2200040650	9410	4/8/57	23.288	0.2345
2200076650	3130	8/6/57	23.820	0.1164	2200043150	9410	4/17/57	23.348	0.2932
2200078550	3130	8/12/57	23.426	0.1869	2200043450	9410	4/19/57	23.876	0.3697
2200079550	3130	8/16/57	21.646	0.0985	2200046650	9410	4/26/57	24.836	0.3720
2200082750	3130	8/23/57	24.293	0.1197	2200049050	9410	5/6/57	25.460	0.3943
2200083250	3130	8/30/57	22.938	0.0863	2200051950	9410	5/13/57	25.656	0.3945
2200088450	3130	9/13/57	23.406	0.1005					

Table 31b (Continued)

Serial No.	Sub- ject code	Date	Potassium γ dis/sec/lb	γ ratio, Cs/K	Serial No.	Sub- ject code	Date	Potassium γ dis/sec/lb	γ ratio, Cs/K
2200144223	9330	3/20/58	23.682	0.3542					
2200146423	9330	3/26/58	23.582	0.3070					
Des Moines, Iowa					Louisville, Ky.				
2200032850	9661	3/13/57	24.552	0.2040	2200094250	2800	10/8/57	29.898	0.3439
2200034950	9661	3/15/57	24.310	0.1758	2200095550	2800	10/11/57	34.874	0.5159
2200036450	9661	3/26/57	23.906	0.2569	2200099250	2800	10/21/57	30.550	0.3901
2200038950	9661	4/2/57	24.082	0.2399	2200100550	2800	10/28/57	27.904	0.2891
2200042150	9661	4/12/57	24.158	0.2083	2200101750	2800	11/4/57	27.730	0.3030
2200042450	9661	4/12/57	24.516	0.2577	2200104950	2800	11/12/57	25.774	0.2916
2200045450	9661	4/23/57	24.414	0.2420	2200107050	2800	11/18/57	26.194	0.3095
2200048250	9661	5/1/57	24.728	0.2065	2200108650	2800	11/26/57	24.554	0.2743
2200050350	9661	5/7/57	24.804	0.2312	2200109750	2800	12/2/57	23.154	0.3633
2200052350	9661	5/13/57	24.712	0.3294	2200115550	2800	12/10/57	25.292	0.2610
2200054450	9661	5/21/57	24.282	0.2464	2200116850	2800	12/16/57	23.608	0.2695
2200056250	9661	5/31/57	24.788	0.4166	2200118650	2800	12/26/57	23.194	0.3715
2200057850	9661	6/4/57	25.320	0.3794	2200119650	2800	12/30/57	25.534	0.2734
2200059850	9661	6/11/57	25.664	0.3659	2200121550	2800	1/8/58	24.668	0.2924
2200061750	9661	6/18/57	26.120	0.3822	2200123950	2800	1/13/58	25.926	0.2391
2200064650	9661	6/25/57	26.730	0.4579	2200125050	2800	1/17/58	25.152	0.3158
2200066150	9661	7/1/57	26.428	0.5201	2200130650	2800	2/5/58	25.086	0.3265
2200068650	9661	7/9/57	25.318	0.3767	2200132450	2800	2/12/58	25.180	0.3041
2200075850	9661	8/9/57	46.492	0.5842	2200132950	2800	2/18/58	25.772	0.2834
2200076750	9661	8/2/57	33.544	0.4043	2200135150	2800	1/29/58	26.150	0.2782
2200079050	9661	8/21/57	41.422	0.6404	2200137550	2800	2/24/58	24.816	0.2830
2200081050	9661	8/16/57	40.702	0.5540	2200139300	2800	2/28/58	25.322	0.2916
2200081750	9661	8/27/57	36.654	0.4906	2200140736	2800	3/12/58	26.294	0.2769
2200087150	9661	9/24/57	41.808	0.6979	2200144136	2800	3/18/58	24.102	0.3138
2200087750	9661	9/17/57	44.228	0.7944	2200144936	2800	3/21/58	24.750	0.3508
2200088650	9661	9/9/57	27.972	0.3462	2200147836	2800	3/31/58	25.218	0.3178
2200093450	9661	10/4/57	42.612	0.4922	2200150136	2800	4/7/58	25.374	0.3797
2200105850	9661	11/14/57	32.418	0.4593	2200032150	2800	3/13/57	23.796	0.2300
2200096050	9661	10/15/57	32.382	0.3924	2200033750	2800	3/20/57	24.464	0.2073
2200097550	9661	10/18/57	53.716	0.7193	2200035950	2800	3/25/57	23.716	0.2807
2200099950	9661	10/28/57	28.404	0.3726	2200037650	2800	4/1/57	22.686	0.2579
2200103850	9661	11/6/57	24.906	0.0964	2200041150	2800	4/8/57	22.914	0.2690
2200107850	9661	11/22/57	27.818	0.4026	2200043050	2800	4/15/57	23.842	0.2894
2200111050	9661	12/2/57	25.222	0.2986	2200045250	2800	4/22/57	26.598	0.3545
2200112050	9661	12/2/57	25.418	0.2701	2200047750	2800	4/29/57	24.828	0.2994
2200113250	9661	12/9/57	24.404	0.1914	2200049750	2800	5/6/57	25.464	0.2785
2200117950	9661	12/23/57	24.294	0.3462	2200052650	2800	5/14/57	24.484	0.1736
2200119150	9661	12/23/57	23.516	0.1516	2200054550	2800	5/21/57	24.552	0.1500
2200121950	9661	1/6/58	24.146	0.2866	2200055250	2800	5/24/57	23.984	0.1742
2200122850	9661	1/10/58	24.260	0.2943	2200057650	2800	6/3/57	24.770	0.3728
2200122950	9410	1/13/58	23.860	0.4646	2200060050	2800	6/12/57	24.446	0.2517
2200125950	9661	1/21/58	24.954	0.2566	2200061150	2800	6/17/57	24.198	0.4586
2200128550	9661	1/28/58	23.414	0.1744	2200065050	2800	6/26/57	25.786	0.4243
2200134350	9661	2/10/58	24.412	0.2836	2200066850	2800	7/2/57	25.268	0.5370
2200135450	9661	2/19/58	24.576	0.3245	2200069150	2800	7/10/57	25.652	0.5271
2200137450	9661	2/24/58	23.712	0.3251	2200070350	2800	7/16/57	32.714	0.5340
2200140344	9661	3/7/58	24.576	0.3119	2200072250	2800	7/21/57	52.920	0.7269
2200142044	9661	3/13/58	24.670	0.3353	2200074450	2800	7/29/57	46.318	0.6562
2200143944	9661	3/18/58	24.166	0.3390	2200075550	2800	8/9/57	78.662	0.9405
2200147244	9661	3/28/58	24.178	0.3418	2200078350	2800	8/5/57	33.290	0.5133
2200148844	9661	4/3/58	24.486	0.3378	2200081450	2800	8/20/57	54.184	0.6923
					2200082450	2800	8/23/57	42.126	0.5594
					2200086250	2800	9/4/57	27.354	0.4032

Table 31b (Continued)

Serial No.	Sub- ject code	Date	Potassium γ dis/sec/lb	γ ratio, Cs/K	Serial No.	Sub- ject code	Date	Potassium γ dis/sec/lb	γ ratio, Cs/K
2200087650	2800	9/16/57	26.840	0.4168	2200132750	3100	2/11/58	23.717	0.6802
2200090350	2800	9/23/57	31.514	0.4993	2200136150	3100	2/19/58	24.359	0.5486
2200091550	2800	10/1/57	30.924	0.4637					
New Orleans, La.					2200138200	3100	3/4/58	22.868	0.5535
2200033850	3100	3/20/57	23.725	0.5761	2200138600	3100	2/28/58	23.336	0.6043
2200034350	3100	3/20/57	23.732	0.5950	2200140981	3100	3/12/58	23.785	0.5756
2200038350	3100	4/3/57	23.679	0.5842	2200142956	3100	3/17/58	22.689	0.5910
2200038550	3100	3/26/57	23.423	0.6262	2200145456	3100	3/24/58	27.711	0.3402
2200044450	3100	4/11/57	24.070	0.4701	2200148556	3100	4/2/58	24.472	1.0309
2200044750	3100	4/16/57	24.804	0.6867	Lansing, Mich.				
2200045850	3100	4/23/57	26.546	0.6115	2200038850	4938	3/28/57	23.204	0.2650
2200047350	3100	4/29/57	26.943	0.6897	2200046250	4938	4/25/57	23.188	0.3342
2200051250	3100	5/7/57	24.907	0.5892	2200055450	4938	5/27/57	24.594	0.2967
2200052850	3100	5/14/57	25.241	0.6165	2200061550	4938	6/19/57	25.970	0.3938
2200054150	3100	5/21/57	25.391	0.6973	2200070950	4938	7/17/57	28.146	0.5108
2200055650	3100	5/28/57	24.908	0.6793	2200079850	4938	8/16/57	24.448	0.3401
2200058150	3100	6/4/57	23.446	0.6741	2200089850	4938	9/20/57	24.366	0.2577
2200059650	3100	6/11/57	23.764	0.6209	2200097850	4938	10/17/57	25.332	0.3339
2200062950	3100	6/24/57	24.277	0.5314	2200106750	4938	11/18/57	24.010	0.4096
2200064350	3100	6/25/57	30.422	0.5836	2200118750	4938	12/23/57	24.610	0.4602
2200067450	3100	7/3/57	25.957	0.6880	2200133050	4938	2/19/58	24.918	0.5663
2200067850	3100	7/9/57	67.724	1.0688	2200125550	4938	1/22/58	23.586	0.5419
2200069750	3100	7/15/57	74.545	0.8593	2200144031	4938	3/17/58	24.964	0.3821
2200071550	3100	7/21/57	50.829	0.7353	Bertha, Minn.				
2200076950	3100	8/1/57	33.081	0.6685	2200054650	4955	5/21/57	22.183	0.5060
2200077150	3100	8/8/57	34.887	0.6652	2200105050	4955	11/12/57	29.655	0.9178
2200078650	3100	8/12/57	30.388	0.7122	2200108150	4955	11/18/57	27.331	0.8993
2200080250	3100	8/20/57	47.400	0.7536	2200136550	4955	11/18/57	21.202	0.8367
2200083650	3100	8/28/57	39.422	0.7543	2200144825	4955	3/24/58	26.868	0.9166
2200085050	3100	9/10/57	26.293	0.7031	2200149625	4955	4/3/58	26.796	0.8971
2200085550	3100	9/6/57	33.914	0.8274	2200150825	4955	4/7/58	26.526	0.8221
2200088250	3100	9/24/57	38.372	0.7901	Claremont, Minn.				
2200089750	3100	9/17/57	24.633	0.7017	2200144733	4955	3/24/58	25.452	0.3821
2200092450	3100	10/2/57	30.586	0.5901	2200145033	4955	3/24/58	25.936	0.3451
2200093950	3100	10/8/57	31.960	0.6230	2200148433	4955	3/31/58	25.730	0.3591
2200096650	3100	10/15/57	39.378	0.6586	Aberdeen, Miss.				
2200099450	3100	10/23/57	49.881	0.8229	2200047150	4922	4/26/57	24.714	0.4145
2200100850	3100	10/30/57	35.129	0.6906	2200083950	4922	8/30/57	33.022	0.4838
2200100950	3100	11/5/57	37.477	0.7127	2200095650	4922	10/11/57	34.196	0.5367
2200105550	3100	11/13/57	30.522	0.7116	2200102950	4922	11/6/57	64.774	0.8604
2200108250	3100	11/18/57	30.198	0.6851	2200110650	4922	12/4/57	27.166	0.6805
2200110750	3100	12/4/57	25.530	0.6179	2200119850	4922	1/2/58	20.331	0.5714
2200112350	3100	11/29/57	24.948	0.5185	2200130150	4922	2/6/58	21.585	0.4901
2200113150	3100	12/10/57	25.356	0.4454	2200141012	4922	3/7/58	22.771	0.4378
2200115250	3100	12/18/57	24.651	0.5036	Springfield, Mo.				
2200118250	3100	12/27/57	22.055	0.6047	2200032450	4000	3/13/57	22.464	0.2161
2200119950	3100	1/2/58	23.676	0.6342	2200034250	4600	3/20/57	22.394	0.2052
2200124950	3100	1/9/58	23.407	0.5561	2200035550	4600	3/22/57	23.036	0.2436
2200126150	3130	1/17/58	24.045	0.5478	2200039250	4600	4/1/57	21.876	0.2916
2200127450	3100	1/24/58	24.293	0.5366					
2200129150	3100	1/28/58	23.829	0.6119					
2200129650	3100	2/5/58	23.621	0.6230					

Table 31b (Continued)

Serial No.	Sub- ject code	Date	Potassium γ dis/sec/lb	γ ratio, Cs/K	Serial No.	Sub- ject code	Date	Potassium γ dis/sec/lb	γ ratio, Cs/K
2200040750	4600	4/5/57	21.302	0.2851	New Mexico (1)				
2200042350	4600	4/12/57	22.548	0.2382	2000028350	3000	1/2/57	2.026	0.1121
2200043350	4600	4/19/57	22.374	0.3200	2000029050	3000	1/11/57	2.034	0.1416
2200046850	4600	4/26/57	22.576	0.3597	2000029350	3000	1/15/57	2.083	0.1053
2200049950	4600	5/6/57	22.694	0.3043	2000029450	3000	1/21/57	2.091	0.0720
2200050750	4600	5/10/57	22.190	0.2744	2000029850	3000	1/31/57	2.025	0.0447
2200051450	4600	5/17/57	23.872	0.2164	2000030150	3000	2/5/57	2.077	0.1406
2200057250	4600	6/3/57	22.370	0.3935	2000030250	3000	2/6/57	2.119	0.0577
2200058450	4600	6/6/57	22.626	0.3545	2000030350	3000	2/15/57	2.023	0.0623
2200060650	4600	6/13/57	25.530	0.6630	2000030950	3000	2/26/57	1.982	0.1156
2200063150	4600	6/24/57	24.408	0.6464	2000031150	3000	3/4/57	2.074	0.1073
2200065750	4600	7/1/57	23.834	0.7760	2000031450	3000	3/11/57	2.016	0.1447
2200067250	4600	7/8/57	22.404	0.5396	2200032350	3000	3/21/57	2.065	0.0987
2200070450	4600	7/16/57	24.824	0.6187	2000045650	3000	5/1/57	2.093	0.0462
2200071250	4600	7/19/57	24.650	0.7092	2000047050	3000	5/15/57	2.119	0.1232
2200072750	4600	7/24/57	23.828	0.6372	2000050250	3000	5/21/57	2.223	0.2362
2200073450	4600	7/26/57	27.000	0.8567	2000057550	3000	6/24/57	2.336	0.6067
2200076050	4600	8/12/57	28.118	0.5131	2000062450	3000	7/2/57	2.672	0.6807
2200080050	4600	8/5/57	25.494	0.9240	2000066350	3000	7/12/57	3.147	1.5426
2200080350	4600	8/19/57	27.116	0.5287	2000067350	3000	7/18/57	4.818	1.2197
2200082050	4600	8/23/57	27.618	0.6331	2000069450	3000	7/23/57	5.665	1.6060
2200083450	4600	8/30/57	27.654	0.5593	2200071150	3000	7/30/57	4.361	0.9612
2200085150	4600	9/10/57	25.592	0.5181	2000074750	3000	8/15/57	2.815	0.4009
2200086950	4600	9/23/57	78.856	1.2388	2000076150	3000	8/21/57	2.327	0.2978
2200087450	4600	9/16/57	24.130	0.4608	2000078150	3000	8/29/57	2.279	0.2399
2200091350	4600	9/27/57	139.016	0.7664	2000084150	3000	9/6/57	2.378	0.4447
2200092750	4600	10/4/57	112.800	0.7209	2000084350	3000	9/7/57	2.531	0.5237
2200095250	4600	10/11/57	83.690	0.6630	2000084450	3000	9/9/57	2.937	0.8634
2200098950	4600	10/25/57	43.264	0.6175	2000084750	3000	9/10/57	3.130	1.1780
2200099050	4600	10/23/57	30.170	0.6099	2000084850	3000	9/17/57	3.468	0.8906
2200101650	4600	11/4/57	24.242	0.5212	2000091950	3000	10/7/57	2.260	0.3973
2200103550	4600	11/5/57	42.382	0.6905	2000094650	3000	10/14/57	2.913	0.4494
2200105650	4600	11/15/57	29.178	0.6900	2000097050	3000	10/24/57	2.613	0.4420
2200109850	4600	12/2/57	24.274	0.7013	2000098650	3000	10/29/57	2.310	0.1685
2200113450	4600	12/9/57	24.534	0.3501	2000099550	3000	11/5/57	2.258	0.1744
2200114050	4600	12/13/57	25.538	0.4348	2000103950	3000	11/14/57	2.066	0.1641
2200116950	4600	12/20/57	23.584	0.3697	2000109350	3000	12/4/57	2.029	0.2170
2200119550	4600	12/30/57	24.056	0.4619	2000109450	3000	12/10/57	2.036	0.2825
2200121150	4600	1/6/58	24.220	0.4650	2000111350	3000	12/18/57	2.031	0.1519
2200123250	4600	1/10/58	24.352	0.4099	2000114350	3000	12/23/57	2.056	0.1814
2200126750	4600	1/12/58	24.076	0.5047	New Mexico (2)				
2200127950	4600	1/27/58	24.146	0.4889	2000027450	6000	12/27/56	2.110	0.0690
2200131750	4600	2/7/58	22.348	0.4234	2000028450	6000	1/3/57	2.130	0.1430
2200131850	4600	1/31/58	22.334	0.4714	2000028950	6000	1/11/57	2.161	0.2554
2200133550	4600	2/21/58	23.792	0.6349	2000029250	6000	1/15/57	2.186	0.1573
2200137150	4600	2/17/58	22.930	0.4152	2000029550	6000	1/23/57	2.062	0.1499
2200139200	4600	2/25/58	22.708	0.5481	2000030450	6000	2/15/57	2.131	0.1018
2200141127	4600	3/7/58	23.248	0.3242	2000031050	6000	2/27/57	2.134	0.3009
2200142327	4600	3/14/58	22.714	0.3895	2000031350	6000	3/7/57	2.218	0.2143
2200144527	4600	3/21/58	22.734	0.3764	2000031650	6000	3/13/57	2.214	0.1563
2200147627	4600	3/28/58	22.492	0.3685	2000035850	6000	3/28/57	1.994	0.1139
2200150427	4600	4/4/58	23.052	0.4354	2000045750	6000	5/1/57	2.162	0.1228
					2000048650	6000	5/16/57	2.031	0.2759

Table 31b (Continued)

Serial No.	Sub- ject code	Date	Potassium γ dis/sec/lb	γ ratio, Cs/K	Serial No.	Sub- ject code	Date	Potassium γ dis/sec/lb	γ ratio, Cs/K
2200101850	6128	11/4/57	25.254	0.6513	2200091650	6128	10/1/57	24.266	0.2773
2200104350	6128	11/12/57	23.686	0.7056	2200094150	6128	10/8/57	25.280	0.2938
2200106350	6128	11/18/57	24.340	0.5804	2200096150	6128	10/14/57	31.182	0.3328
2200107650	6128	11/25/57	23.186	0.5672	2200098250	6128	10/21/57	33.078	0.4040
2200110950	6128	12/2/57	22.984	0.4948	2200099850	6128	10/28/57	27.064	0.3215
2200114750	6128	12/16/57	23.146	0.5418	2200102650	6128	11/7/57	27.930	0.3338
2200115750	6128	12/9/57	23.454	0.4634	2200105950	6128	11/14/57	24.302	0.2548
2200118350	6128	12/30/57	23.438	0.5406	2200106650	6128	11/18/57	25.236	0.2860
2200119050	6128	12/23/57	23.570	0.5167	2200108950	6128	11/26/57	22.838	0.2151
2200121050	6128	1/3/58	25.800	0.4918	2200110250	6128	12/4/57	22.658	0.2120
2200123150	6128	1/13/58	23.654	0.4652	2200112550	6128	12/9/57	23.114	0.1589
2200125650	6128	1/20/58	24.082	0.6969	2200116650	6128	12/17/57	22.650	0.1804
2200128250	6128	1/24/58	23.792	0.5060	2200120550	6128	1/2/58	23.200	0.1897
2200130350	6128	2/3/58	23.976	0.4475	2200121450	6128	1/6/58	23.116	0.1885
2200134050	6128	2/24/58	24.496	0.5309	2200123050	6128	1/13/58	23.152	0.2097
2200134650	6128	2/17/58	24.150	0.5098	2200125850	9668	1/21/58	23.686	0.2016
2200138924	6128	3/3/58	24.038	0.4897	2200128450	6128	1/28/58	24.238	0.3013
2200142224	6128	3/10/58	24.052	0.5916	2200134150	6128	2/12/58	23.706	0.2536
2200142724	6128	3/17/58	24.346	0.5773	2200135550	6128	2/17/58	23.930	0.1956
2200145324	6128	3/24/58	24.134	0.6503	2200135750	6128	2/3/58	24.048	0.1613
2200147724	6128	4/3/58	25.222	0.7074	2200137350	6128	2/24/58	23.328	0.2011
Sunnyside, Wash.					2200138322	6128	2/4/58	22.886	0.2155
2200032550	6128	3/13/57	22.852	0.1826	2200143622	6128	3/18/58	22.710	0.2181
2200034850	6128	3/21/57	22.976	0.2517	2200146022	6128	3/24/58	24.190	0.2453
2200038050	6128	3/29/57	23.134	0.2258	2200148722	6128	4/2/58	24.614	0.3393
2200039150	6128	4/2/57	23.686	0.2545	Ellensburg, Wash.				
2200041850	6128	4/9/57	23.290	0.2392	2200037950	6128	4/1/57	23.476	0.3066
2200042750	6128	4/15/57	24.306	0.2734	2200062150	6128	6/19/57	38.724	0.7083
2200045350	6128	4/23/57	24.892	0.2698	2200090550	6128	9/23/57	22.523	0.1166
2200047650	6128	4/30/57	24.296	0.3354	2200096750	6128	10/16/57	26.733	0.3552
2200047950	6128	5/1/57	24.452	0.2629	2200102550	6128	11/6/57	23.158	0.2019
2200050850	6128	5/7/57	24.902	0.2516	2200114850	6128	12/17/57	22.504	0.2853
2200050950	6128	5/13/57	24.410	0.2465	2200128850	6128	1/27/58	23.390	0.2880
2200054350	6128	5/21/57	24.382	0.3761	2200142853	6128	3/18/58	23.441	0.2628
2200056050	6128	5/28/57	24.286	0.3677	Laydysmith, Wis.				
2200057050	6128	5/31/57	24.424	0.3918	2200033450	6920	3/18/57	18.970	0.6331
2200059750	6128	6/11/57	25.656	0.3457	2200036350	6920	3/25/57	24.116	0.5860
2200061250	6128	6/18/57	34.790	1.6327	2200040850	6920	4/5/57	24.998	0.6725
2200064150	6128	6/25/57	31.300	0.4359	2200041550	6920	4/8/57	25.930	0.6719
2200066050	6128	7/2/57	29.140	0.4246	2200042250	6920	4/12/57	25.216	0.6450
2200069050	6128	7/9/57	25.308	0.2827	2100043950	6920	4/22/57	18.904	0.6979
2200070750	6128	7/17/57	24.948	0.2146	2100046750	6920	4/26/57	18.560	0.7296
2200072550	6128	7/23/57	24.138	0.1932	2200049450	6920	5/7/57	26.086	0.6743
2200074650	6128	7/31/57	24.296	0.1934	2200053050	6920	5/16/57	25.322	0.6797
2200077450	6128	8/6/57	22.922	0.1486	2200054850	6920	5/22/57	28.290	0.7053
2200078750	6128	8/13/57	23.996	0.1799	2200056450	6920	5/29/57	24.202	0.7435
2200079150	6128	8/21/57	24.726	0.2105	2200057750	6920	6/4/57	25.474	0.6844
2200081550	6128	8/27/57	23.912	0.1531	2200059550	6920	6/11/57	25.308	0.9140
2200086750	6128	9/24/57	22.766	0.1179	2200060550	6920	6/13/57	26.762	0.8413
2200087250	6128	9/17/57	22.760	0.1460	2200064850	6920	6/25/57	26.440	0.8923
2200088750	6128	9/9/57	23.918	0.1297	2200067050	6920	7/5/57	30.024	1.1505
2200089050	6128	9/13/57	23.756	0.1414					

Table 31b (Continued)

Serial No.	Sub- ject code	Date	Potassium γ dis/sec/lb	γ ratio, Cs/K	Serial No.	Sub- ject code	Date	Potassium γ dis/sec/lb	γ ratio, Cs/K
2200069550	6920	7/12/57	28.812	0.9209	2200119750	6920	1/2/58	24.397	0.6457
2200072450	6920	7/23/57	35.124	1.1069	2200123450	6920	1/10/58	25.046	0.5701
2200074550	6920	7/31/57	40.974	0.9495	2200129050	6920	1/28/58	24.627	0.5902
2200075950	6920	8/9/57	27.967	0.9446	2200130450	6920	2/5/58	25.388	0.6614
2200081250	6920	8/16/57	46.122	0.8870	2200130550	6920	2/3/58	19.230	0.6679
2200084650	6920	9/4/57	33.086	0.7960	2200134950	6920	2/20/58	25.316	0.5802
2200085950	6920	9/3/57	28.622	0.8509	2200136450	6920	11/13/57	22.202	0.7226
2200090050	6920	9/20/57	45.770	0.8136	2200136750	6920	12/19/57	22.592	0.6051
2200093350	6920	10/3/57	91.472	1.0733	2200136850	6920	1/10/58	23.616	0.5897
2200094550	6920	10/7/57	104.448	0.9979	2200136950	6920	1/28/58	24.230	0.6002
2200096450	6920	10/11/57	43.608	0.7427	2200140431	6920	3/11/58	23.101	0.6248
2200098450	6920	10/21/57	34.756	0.8427	2200143731	6920	3/18/58	21.499	0.6741
2200103050	6920	11/6/57	30.360	0.9139	2200146531	6920	3/25/58	25.090	0.6230
2200103150	6920	11/6/57	34.368	0.7640	2200149731	6920	4/2/58	26.036	0.7049
2200105450	6920	11/13/57	30.320	0.7999			Deerfield, Wis.		
2200107750	6920	11/25/57	26.452	0.7313	2200145145	6920	3/21/58	26.427	0.3804
2200116050	6920	12/19/57	23.962	0.5885	2200148145	6920	3/31/58	25.791	0.3850
2200116250	6920	12/17/57	24.011	0.6398	2200149045	6920	4/2/58	26.062	0.3872

Table 31c—Cs¹³⁷ DETERMINATIONS IN MILK
(Measured at the Los Alamos Scientific Laboratory)

Serial No.	Subject code	Date	Potassium γ dis/sec/lb	γ ratio Cs/K
Canada				
2200148671	6530	4/2/58	26.692	0.3235
2200148971	6530	4/2/58	27.136	0.3424
2200150971	6530	4/7/58	27.312	0.4293
2200145229	3150	3/25/58	26.606	0.3856
2200148329	6530	3/31/58	26.554	0.3833
Argentina				
2100030550	1970	Nov. 1956	17.615	0.1541
2200039750	1970	12/21/56	23.489	0.1321
2100039850	1970	12/17/56	20.051	0.1239
2100039950	1970	Dec. 1956	20.178	0.0932
2200040050	1970	Dec. 1956	22.622	0.0447
Australia				
2200030050	1423	11/2/56	20.400	0.2467
2200052050	1423	1/12/57	22.604	0.2405
2200052150	1423	2/18/57	22.471	0.2406
2200052250	1423	3/5/57	21.788	0.4077
2200077750	1423	6/5/57	23.236	0.1588
2200077850	1423	5/8/57	23.379	0.1257
2200077950	1423	4/23/57	22.804	0.1577
2200102150	1423	7/1/57	22.716	0.2952
2200102250	1423	9/1/57	22.833	0.2199
2200102350	1423	8/1/57	22.776	0.2822
2200124650	1423	10/23/57	24.388	0.1803
2200124750	1423	11/8/57	24.259	0.1819
2200124450	1423	12/2/57	24.514	0.1675

Table 32—Sr⁹⁰ IN CANNED FISH

Type	Remarks	Date received at HASL	Sr ⁹⁰ , dis/min/kg (wet)
Yellowfin	NE Pacific, Gulf of Tehautepac	4/20/56	3.5 ± 1.2
Yellowfin	Region of Marquesas Islands	4/20/56	≤1.5
Albacore	Western Pacific	4/20/56	5.9 ± 2.4
Alaska Pink Salmon	Local Purchase	5/26/56	≤0.98
Bonito	Local Purchase	5/26/56	5.3 ± 2.3
Bonito	Local Purchase	5/26/56	8.5 ± 3.7
Bonito	Local Purchase	6/2/56	2.2 ± 1.4
Alaska Pink Salmon	Local Purchase	6/18/56	3.9 ± 1.5
Albacore	Western Pacific	6/19/56	2.5 ± 0.8
Yellowfin	Caught off Cape San Lucas	6/19/56	1.8 ± 1.1
Alaska Pink Salmon	Local Purchase	7/3/56	2.9 ± 1.2
Bonito	Local Prurchase	7/3/56	3.7 ± 1.3
Yellowfin	Lower California, Eastern Pacific	8/1/56	≤1.7
Albacore	Western Pacific	8/1/56	3.8 ± 1.5
Alaska Pink Salmon	Local Purchase	8/6/56	1.5 ± 0.7
Bonito	Local Purchase	8/6/56	0.77 ± 0.50
Alaska Pink Salmon	Local Purchase	9/4/56	1.9 ± 1.2
Bonito	Local Purchase	9/4/56	2.4 ± 0.9
Tuna	Cocos Islands, Costa Rica, Nicaragua	9/7/56	1.4 ± 1.0
Tuna	Western Pacific	9/7/56	2.2 ± 0.8
Alaska Pink Salmon	Local Purchase	10/3/56	4.6 ± 0.7
Bonito	Local Purchase	10/3/56	1.2 ± 0.7
Alaska Pink Salmon	Local Purchase	11/19/56	4.2 ± 0.6
Bonito	Local Purchase	11/19/56	≤0.7
Tuna	Eastern Pacific	11/19/56	5.2 ± 0.7
Tuna	Western Pacific	11/19/56	4.0 ± 0.8
Tuna	Western Pacific	1/7/57	≤0.35
Tuna	Eastern Pacific	1/7/57	0.63 ± 0.42
Tuna	Western Pacific	2/14/57	3.26 ± 0.24
Tuna	Eastern Pacific	2/14/57	1.16 ± 0.23
Tuna	Eastern Pacific	3/7/57	3.24 ± 0.28
Tuna	Western Pacific	3/7/57	≤0.32
Alaska Pink Salmon	Local Purchase	3/18/57	1.26 ± 0.41
Bonito	Local Purchase	3/18/57	1.41 ± 0.24
Tuna	Western Pacific	4/9/57	≤0.47
Tuna	Eastern Pacific	4/9/57	2.03 ± 0.28
Tuna	Western Pacific	5/20/57	≤0.3
Tuna	Eastern Pacific	5/20/57	0.55 ± 0.35
Alaska Pink Salmon	Local Purchase	5/23/57	0.24 ± 0.17
Bonito	Local Purchase	5/23/57	0.78 ± 0.36
Alaska Pink Salmon	Local Purchase	6/20/57	≤0.37
Bonito	Local Purchase	6/20/57	≤0.41
Tuna	Western Pacific	7/9/57	1.7 ± 0.4
Tuna	Eastern Pacific	7/9/57	≤0.72
Tuna	Eastern Pacific	8/6/57	≤0.26
Tuna	Western Pacific	8/6/57	1.2 ± 0.4
Tuna	Local Purchase	8/8/57	≤0.41
Alaska Pink Salmon	Local Prurchase	8/8/57	≤0.44
Tuna	Eastern Pacific	9/24/57	
Tuna	Western Pacific	9/24/57	

Table 33—Sr⁹⁰ IN UNITED STATES FOOD*

Sampling date	Type	Ca in Ash, %	Sr ⁹⁰ /g Ca, $\mu\mu\text{c}$
Brawley, California (Southwestern Irrigation Field Station and Arena Co. Farm)			
1/5/56	Lettuce	4.68	0.39 ± 0.05
1/5/56	Broccoli	10.61	0.25 ± 0.08
1/5/56	Peas	10.00	1.34 ± 0.08
2/28/57	Pea pods	5.90	≤0.3
2/28/57	Broccoli	9.5	1.10 ± 0.07
2/28/57	Cantaloupe rind and flesh	9.4	≤0.33
2/28/58	Cantaloupe seeds	12.1	≤0.24
Ithaca, New York (Shapley Farm)			
7/24/57†	Cabbage	3.87	23.2 ± 2.4
7/29/57‡	Beans	11.3	5.99 ± 0.7

*Samples collected by L. T. Alexander, USDA.

†Planted, 5/23/57.

‡Planted, 6/6/57.

Table 34—Sr⁹⁰ IN COMMON UNITED STATES FOODS 1956–1957
(Data from Lamont Geological Observatory)

Location	Sample	Date	Sr ⁹⁰ , $\mu\mu\text{c/g Ca}$
Maine	Peas	Aug. 1956	21.3
Western New York State	Beans, cut green	Aug. 1956	20.2
	Beans, cut green	Sept. 1956	18.4
	Beans, cut green	Sept. 1956	8.6
	Beans, wax	July 1957	13.6
	Beans, wax	Aug. 1957	11.3
	Cauliflower	Oct. 1956	9.1
	Corn	Sept. 1956	28.4
	Spinach	June 1957	1.8
Eastern Pennsylvania, New Jersey, and Long Island	Asparagus	June 1956	1.2
	Asparagus	May 1957	1.1
	Beans, cut green	Dec. 1956	4.6
	Beans, cut green	Sept. 1956	8.0
	Beans, lima	Sept. 1956	6.6
	Cauliflower	Fall 1956	8.1
	Peas	June 1957	10.0
	Potatoes, sweet	1957	13.3
	Potatoes, white	1957	6.1
Squash	Fall 1956	11.5	
Eastern Maryland and Delaware	Asparagus	Oct. 1956	1.7
	Beans, lima	1956	2.9
	Beans, lima	Sept. 1956	8.4
	Broccoli	Oct. 1956	4.7
	Broccoli	Oct. 1956	6.7
	Broccoli	Oct. 1956	8.5
	Peas	Dec. 1956	3.6
	Peas	Dec. 1956	1.3

Table 34 (Continued)

Location	Sample	Date	Sr ⁹⁰ , μuc/g Ca
Tennessee	Okra	July 1957	18.0
	Spinach		6.1
	Spinach	Apr. 1957	1.2
	Turnip greens	May 1957	21.3
	Turnip greens	Feb. 1956	7.8
Minnesota	Corn	Sept. 1956	1.6
	Peas	June 1956	5.8
Washington, Idaho, and Oregon	Beans, lima	Sept. 1955	6.3
	Broccoli	Sept. 1956	3.7
	Corn	Aug. 1957	2.1
	Peas	June 1957	4.8
	Peas	July 1956	7.8
	Peas	June 1956	3.0
	Potatoes	1957	8.7
	Squash	Sept. 1956	3.1
	Squash	Oct. 1956	3.7
California	Asparagus	Apr. 1957	1.8
	Beans, lima	May 1957	4.6
	Beans, lima	Sept. 1955	10.0
	Beans, lima	Sept. 1956	4.3
	Broccoli	Apr. 1957	4.0
	Brussels sprouts	Oct. 1956	12.0
	Brussels sprouts	Sept. 1956	4.3
	Brussels sprouts	Dec. 1956	2.5
	Brussels sprouts	Nov. 1956	1.1
	Cauliflower	Oct. 1956	28.5
	Cauliflower	Apr. 1957	22.5
	Spinach	Mar. 1957	13.9
	Spinach	Mar. 1957	9.1
	Spinach	Mar. 1957	9.5
New York State	Wheat	1956	22.8
Washington	Wheat	1955-1956	9.1
Michigan	Bran	Summer 1957	8.6
Illinois	Flour	July 1956	6.7
Unknown	Rice	1956	4.0
	Wheat	1956	37.5
	Oatmeal	1956	5.7

Table 35 — CHEESE SAMPLES ANALYZED AT THE UNIVERSITY OF CHICAGO

Sample No.	Date of manufacture	Type	Strontium units	Ca in Ash, %
United States				
CL 18	July 1953	Wisconsin Swiss	1.16 ± 0.05	0.93
CL 19	July 1953	Wisconsin Munster	2.07 ± 0.07	0.56
CL 175	July 1953	Wisconsin Munster	1.53 ± 0.03	--
CL 198-P	Mar. 1954	Wisconsin Romano	0.20 ± 0.01	0.59
CL 199	Jan. 1954	Wisconsin Sharp Cheddar	0.36 ± 0.02	0.38
CL 224	Apr. 1954	Wisconsin Swiss	1.36 ± 0.05	0.50
CL 225	May 1954	Wisconsin Munster	1.63 ± 0.06	0.31
CL 291	Aug. 1954	Wisconsin Swiss	1.51 ± 0.09	--
CL 293	Sept. 1954	Wisconsin Munster	2.24 ± 0.09	0.22
CL 335	Dec. 1954	Wisconsin Munster	1.66 ± 0.05	0.39
CL 337-P	Nov. 1954	Wisconsin Swiss	3.35 ± 0.10	0.52
CL 564-P	Jan. 1955	Domestic Swiss	2.98 ± 0.17	0.51
CL 565-P	Mar. 1955	Wisconsin Munster	2.02 ± 0.09	0.41
CL 707-P	Apr. 1955	Domestic Swiss	10.4 ± 0.4	0.75
CL 7-9-P	July 1955	Wisconsin Munster	2.41 ± 0.06	--
CL 836	Oct. 1955	Domestic Munster	6.7 ± 0.3	0.22
CL 838	Sept. 1955	Domestic Swiss	6.8 ± 0.2	0.90
CL 1036-P	Jan. 1956	Domestic Munster	3.37 ± 0.21	0.08
CL 1038-P	Dec. 1955	Domestic Swiss	4.70 ± 0.28	0.15
Foreign (Northern Hemisphere)				
CL 120	Spring 1953	Danish Blue	0.99 ± 0.02	0.41
CL 200	Fall 1954	Danish Blue	0.424 ± 0.017	0.44
CL 227	Feb. 1954	Danish Blue	0.38 ± 0.03	0.20
CL 294-P	Apr. 1954	Danish Blue	0.65 ± 0.05	0.19
CL 334	Sept. 1954	Danish Blue	1.81 ± 0.05	0.12
CL 567-P	Sept. 1954	Danish Blue	0.36 ± 0.03	0.41
CL 710-P	Mar. 1955	Danish Blue	2.21 ± 0.05	--
CL 849	July 1955	Danish Blue	2.6 ± 0.2	0.16
CL 1035-P	Fall—Winter 1955	Danish Blue	11.0 ± 0.7	0.06
CL 121	Spring 1953	Imported Dutch Edam	1.10 ± 0.02	0.80
CL 20	Spring 1953	Imported Swiss	1.25 ± 0.15	1.12
CL 119	Spring 1953	Imported Swiss	2.70 ± 0.05	0.84
CL 226	Dec. 1953	Imported Swiss	1.13 ± 0.05	0.50
CL 292	Jan. 1954	Imported Swiss	1.54 ± 0.04	0.23
CL 336	June 1954	Imported Swiss	1.34 ± 0.05	0.75
CL 566-P	Sept. 1954	Imported Swiss	5.1 ± 0.3	0.36
CL 708-P	Feb. 1955	Imported Swiss	2.27 ± 0.13	0.74
CL 839	May 1955	Imported Swiss	9.33 ± 0.24	0.75
CL 1037-P	June 1955	Imported Swiss	1.06 ± 0.05	0.20
CL 174	Early 1953	Praia da Vitoria	2.69 ± 0.06	--
CL 58	Summer 1953	Japanese Meiji	0.110 ± 0.005	0.72
CL 59	Summer 1953	Japanese Hokkaido	0.136 ± 0.004	0.94
Foreign (Southern Hemisphere)				
CL 197	Jan. 1954	African, Reivilo	0.20 ± 0.05	0.96
CL 262	Feb. 1954	Sbrinz, Buenos Aires	0.31 ± 0.03	0.44
CL 263	Feb. 1954	Huallanca, Cajamarca	0.39 ± 0.03	0.44
CL 669-P		Cheddar, Perth	1.26 ± 0.13	0.84

Table 36—CHEESE SAMPLES ANALYZED AT THE LAMONT GEOLOGICAL OBSERVATORY

Sample No.	Date of manufacture	Location	Sr ⁹⁰ /g Ca, $\mu\mu\text{c}$
North America			
C-4	July 1954	Madison, Wisconsin	1.21 ± 0.14
C-13	Aug. 20, 1953	Manhattan, Montana	0.68 ± 0.10
C-12	Oct. 31, 1954	Manhattan, Montana	0.50 ± 0.02
C-14	Nov. 1, 1953	Manhattan, Montana	0.75 ± 0.03
Europe			
C-1	Early 1953	Praia da Vitoria, Azores	2.85 ± 0.10
C-15	May 18, 1953	Vale de Cambra, N. Portugal	1.10 ± 0.05
C-17	Feb. 1954	Gilbard, S. Italy	0.13 ± 0.02
C-3	Early 1953	Oslo, Norway	1.03 ± 0.10
C-20	Mar. 1954	Trondheim, Norway	0.93 ± 0.06
C-18	July 1954	Olsborg, Norway	2.00 ± 0.37
C-26	Mar. 1952	Gouda, Holland	0.95 ± 0.06
C-25	May 1953	Bremen, Germany	1.99 ± 0.02
Africa			
C-5	Jan. 31, 1954	Ermelo (Transvaal), Africa	0.15 ± 0.03
C-8	Early 1954	Usimbura, Ruanda Urundi	0.82 ± 0.10
C-10	Early 1954	Casablanca	0.77 ± 0.10
C-6	Feb. 11, 1954	Zastron	0.97 ± 0.05
C-11	Early 1954	Johannesburg	0.61 ± 0.07
C-7	Jan. 25, 1954	Reivilo	0.23 ± 0.06
Asia			
C-9	Early 1954	Allahabad U.P., India	0.31 ± 0.05

Table 37—CHEESE SAMPLES ANALYZED FOR Sr⁹⁰ AT HASL

Sampling date	Location	Ca in Ash, %	Sr ⁹⁰ /g Ca, $\mu\mu\text{c}$
Apr. 1957	Arnhem, Netherlands	14.7	5.04 ± 0.76
May 1957	Arnhem, Netherlands		4.00 ± 0.14
1954	Turkey	20.0	1.01 ± 0.20
1954	Ruanda, Africa	17.3	0.95 ± 0.18

Table 38—DIET SAMPLING SURVEYS CONDUCTED OUTSIDE THE UNITED STATES

1. PHILLIPINE ISLANDS (J. A. Scharffenberg, M. D., Interdepartmental Committee on Nutrition for National Defense)

Food (Samples pooled and remilked)				
Collection dates, 1957	Origin	Ca in Ash, %	Dis/min/s	Sr ⁹⁰ /g Ca, $\mu\mu\text{c}$
2/12-2/14	Ft. Wm. McKinley	7.1	≤ 0.4	≤ 3
2/19-2/20	Nichols Air Base	8.2	≤ 0.4	≤ 3
2/25-2/26	2nd ECB, Nueva Ecija	5.4	≤ 0.4	≤ 4
2/28	Ordnance Maintenance Co., Camp Ord. Tarlac	9.7	≤ 0.6	≤ 12
3/4-3/5	82nd P. C. Co., Jolo	5.4	≤ 0.4	≤ 5
3/4-3/5	84th P. C. Co., Jolo	8.3	≤ 0.7	≤ 8
3/9, 3/11, 3/12	Ordnance Co. III MA, Cebu City	6.4	≤ 0.4	≤ 4
3/20, 3/21	Signal Service Bn. Diliman QC	6.6	≤ 0.4	≤ 5
3/20, 3/21	Signal Service Bn. Diliman QC	4.8	0.8 ± 0.6	11 ± 8
3/25, 3/26	Medical Detachment Q.C., V. Luna Gen.	6.3	≤ 0.8	≤ 8
3/25, 3/26	Medical Detachment Q.C., V. Luna Gen.	4.8	≤ 0.5	≤ 6
			≤ 0.6	

Urine (Samples, pooled and remilked)

Area	No. of composited specimens	Total volume, liters	Dis/min/s	Sr ⁹⁰ , dis/min/liter
Ft. McKinley, Manila, V. Luna Hospital, Constabrilaz HQ.	70	2.1	≤ 0.5	≤ 0.3
Laur, Cabanatuan, Munez, Tarlac, Pampanga (C. Luzon)	104	1.86	≤ 0.6	≤ 0.4
Jolo, Cagazan de Oro, Cebu City, Bacold, Tadoban	130	1.7	≤ 0.6	≤ 0.4
Nichol's Field, Cavite Naval Base, Camp Diliman, Laguna Dinalupihan	120	1.53	≤ 0.5	≤ 0.4
			3.4 ± 1.0	0.47 ± 0.14

2. LIBYA (Arnold E. Schaefer, Executive Director, Interdepartmental Committee of Nutrition for National Defense)

Food (Composition of the ration consumed by the Libyan armed forces and provincial police)

Collection date, 1957	Area	Man's daily intake, %	Total wet weight, g	Total Ca, g	Dis/min/s
7/3	Tripoli, Tripolitania	20	781	≤ 0.10	1.30 ± 0.62
	Zaria, Tripolitania	20 (of two man-days rations)	648	≤ 0.10	6.52 ± 0.48
			513	≤ 0.15	4.50 ± 0.44
7/22	Bengazi, Cyrenaica	20	662	≤ 0.10	3.00 ± 0.43
7/24	Bengazi, Cyrenaica	20	664	≤ 0.10	1.09 ± 0.41
	Sussa, Cyrenaica	20	788	≤ 0.10	1.46 ± 0.63
8/9	Sebha, Fezzan*	20	820	≤ 0.10	2.15 ± 0.33

*Fezzan samples obtained from troops ~600-700 miles south of the Mediterranean. The remaining samples represent a fairly narrow band of area along the Mediterranean.

Table 38 (Continued)

Urine (Samples below represent over-all composite of 150 men)

Area	Total volume, ml	Sr ⁹⁰ , dis/min/s	Sr ⁹⁰ , dis/min/liter
Tripoli, Tripolitania	1010	≤0.28	≤0.27
Tripoli, Tripolitania	1005	≤0.44	≤0.44
Sussa, Cyrenaica	1010	≤0.39	≤0.38
Sebha, Fezzan*	956	0.37 ± 0.28	0.38 ± 0.29
Sebha, Fezzan*	940	≤0.33	≤0.35
Bengazi, Cyrenaica	1000	≤0.44	≤0.44

3. TURKEY

Type	Collection date, 1957	Area	Food		Total Ca, g	Sr ⁹⁰ , dis/min/s	Sr ⁹⁰ /g Ca, μμc
			Dry, g	Ash, g			
Wheat	6-10	Ankara	57.93	1.91	0.205	≤0.4	≤0.9
Bulgur*	6-6	Ankara	96.18	1.47	0.084	1.7 ± 0.4	9.2 ± 2.0
Nohut	6-10	Ankara	65.42	0.57	0.071	0.7 ± 0.3	4.5 ± 1.9
Navy beans	6-10	Ankara	129.17	5.88	0.371	≤0.4	≤0.5
Soft white cheese	6-6	Ankara		9.72	0.645	5.0 ± 0.8	3.5 ± 0.6
Yogurt	6-12	Ankara		3.15	0.628	1.8 ± 0.6	1.3 ± 0.4
†	4-18	Conkaya		10.4	0.146	≤0.4	≤1.2
‡	4-24	Iskenderun		24.7	0.132	≤0.6	≤2.5
§	5-30	Erzurum		12.5	0.112	1.0 ± 0.4	4.1 ± 1.5

Urine (Composited samples)

Total volume, ml	Sr ⁹⁰ , dis/min/s	Sr ⁹⁰ , dis/min/liter
340	≤1.5	≤4.5
490	≤1.3	≤3.0
280	≤1.5	≤5.5
Samples, pooled and remilked	4.1 ± 1.4	3.7 ± 1.3

*Representative believes this bulgur to be made from U. S. wheat, although made in Ankara.

†Four-day food composite: 2 days, 209 g of food (5% of 184 g H₂O intake) 10.5 g oxalic acid.

‡Food is equal to 5% of the 5.652 kg food consumed per man in 3 days (283.0 g of food + 349.0 g of added water. 14.2 g oxalic acid.

§2.5% man intake: 164.9 g food + 192.8 g H₂O - 8.3 g oxalic acid.

4. TAIWAN (Samples collected in August 1957)

Type	Ca in Ash, %	Sr ⁹⁰ , μμc/g Ca
Colza (small)	8.17	8.16 ± 0.34
Sweet potato leaves	4.37	20.3 ± 0.4
Green peppers	1.85	≤2.14
Squash (old)	0.64	≤2.82
Fresh mustard leaves	7.39	14.3 ± 0.4
Cabbage (small)	10.0	60.3 ± 0.5
Cowpea Vigea Sinesis	5.35	7.84 ± 0.46
Chinese lettuce leaves	4.95	23.3 ± 0.8
Youn Tasi (water convoloulus)	7.53	23.4 ± 0.7

Table 38 (Continued)

5. ARGENTINA (Samples collected in November 1957)

Type	Area	Ca in Ash, %	Sr ⁹⁰ , μμc/g Ca
Dried whole milk	P. Buenos Aires Z. Magdalena	16.4	1.66 ± 0.27
Dried whole milk	P. Buenos Aires Z. Chivilcoy	16.6	1.56 ± 0.26
Dried whole milk	P. Cordoba Z. Villa Nueva	16.2	1.36 ± 0.18
Dehydrated potatoes	P. Mendoza Z. Tupungato	0.21	12.2 ± 3.0
Dehydrated potatoes	P. Tecuman Z. Rio Colorado	0.44	6.8 ± 1.2
Wheat	Z. 2 Norte y 2 Sur	0.52	1.42 ± 0.67
Wheat	Z. 1, y 5 Norte	3.57	<0.68
Wheat	Z. 3	3.81	12.6 ± 0.4
Wheat	Z. 4, y 5 Sur	1.89	17.5 ± 0.8

6. CHILE (Samples collected in November 1957)

Type	Area	Ca in Ash, %	Sr ⁹⁰ , μμc/g Ca
Potatoes	Coquimbo	1.52	≤0.47
Noodle flour	Ovalle	1.87	55.2 ± 0.9
Noodle flour	Ovalle		2.43 ± 0.12
Powdered Milk	Santiago	14.4	2.95 ± 0.08
Dehydrated green vogs.	Santiago	5.56	6.10 ± 0.69
Fish flour	Santiago	2.75	≤0.042

7. PERU

Type	Sampling date, 1957	Area	Ca in Ash, %	Sr ⁹⁰ , μμc/g Ca
Rice (polished)	11-11	Lima	6.69	0.31
Beans (dried)	11-11	Lima	2.22	0.36
Sweet potatoes	11-11	Lima	4.16	1.60 ± 0.20
10 Guanay birds (including feathers)	11-11	Lima	25.6	0.04
Beans	11-3	Puira	1.96	2.54 ± 0.75
Dried mushrooms	10-20	Huancayo-Tarma	7.66	1.50 ± 0.29
Barley grain	10-20	Huancayo-Tarma	1.74	2.47 ± 0.52
Wheat	10-20	Huancayo-Tarma	2.98	3.40 ± 0.28
Corn (shelled)	10-20	Huancayo-Tarma	3.63	3.08 ± 0.63
Barley	10-15	Cajamarca	11.22	0.68
Wheat	10-15	Cajamarca	8.01	0.18
Beans (broad)	10-15	Cajamarca	5.68	2.13 ± 0.26
Millet	10-3	Puno	2.52	7.74 ± 0.61
Barley	10-3	Puno	1.32	0.87
Wheat	10-3	Puno	3.24	4.52 ± 0.57
Beans (broad)	10-3	Puno		
Rice	10-30	Lqitos	No Ca determined	0.20 ± 0.04 dis/min Sr ⁹⁰ /g Ash
Beans	10-30	Lqitos	2.56	1.58 ± 0.28
Manihot			2.54	1.22 ± 0.38

Table 39—MISCELLANEOUS VEGETATION, 1956 TO 1957

Location	Sampling date	Type	Ca in ash, %	Sr ⁹⁰ /g Ca, μc
Adelaide, Australia	5/7/56	Alfalfa	19.1	1.5 ± 0.5
Antofogasta, Chile	Feb. 1956	Cactus	15.8	0.6 ± 0.2
Nagasaki, Japan	Spring 1957	Bamboo shoots	0.85	11 ± 8
Hanover, N. H.	July 1956	Hay	4.2	69 ± 4
Hanover, N. H.	July 1956	Hay	4.0	104 ± 5
Hanover, N. H.	6/28/57	Hay	7.8	80 ± 3
Hanover, N. H.	6/28/57	Hay	8.0	75 ± 4
Hanover, N. H.	8/23/57	Hay	8.2	88 ± 3
Hanover, N. H.	8/23/57	Hay	8.2	105 ± 5
Hanover, N. H.	8/29/57	Elm leaves	11.8	13 ± 4

Table 40—STRONTIUM 90 IN HUMAN URINE

Sample type	HASL personnel		New York Naval Shipyard Employees (Individual samples collected August 1956).	
	Collection period, 1956	Sr ⁹⁰ , dis/min/liter	Sr ⁹⁰ , dis/min/liter	
Pooled	March	1.6 ± 0.4	1.3 ± 0.2	1.1 ± 0.3
			< 0.24	
Pooled	June	1.4 ± 0.2	1.2 ± 0.2	2.3 ± 0.3
Pooled	June	1.9 ± 0.2	1.1 ± 0.3	< 0.20
Pooled	June	1.0 ± 0.2	1.2 ± 0.5	
Individual	September	0.6 ± 0.2	0.95 ± 0.28	0.82 ± 0.25
Individual	September	1.0 ± 0.2	0.92 ± 0.28	
Pooled	September	1.3 ± 0.2		

Table 41—MISCELLANEOUS ANIMAL BONE, HASL

Location	Sampling date, 1956	Type	Sr ⁹⁰ /g Ca, $\mu\mu\text{c}$
Near Adelaide, Australia	5/10	Sheep (yearling)	2.40 ± 0.12
Manila, Phillipine Islands	7/9	Sheep (yearling)	4.3 ± 0.2
Hiroshima, Japan	Spring	Goat	6.8 ± 1.2
Nagasaki, Japan	Spring	Goat	5.0 ± 0.7
Timaru, New Zealand	Spring	Sheep	5.0 ± 0.6
New Zealand	Spring	Sheep	13 ± 1
Punta Arenas, Chile	1/23	Sheep	7.3 ± 1.0
Froya, Norway	September	Sheep	32.4 ± 0.13
Orlandet, Norway	September	Sheep	11.6 ± 0.1
Stjordal, Norway	September	Sheep	26.6 ± 0.2
Oslo, Norway	September	Sheep	7.46 ± 0.05
Ringsaker, Norway	September	Sheep	16.1 ± 0.1
Lesja, Norway	September	Sheep	6.37 ± 0.05
Kirkenær, Norway	September	Sheep	14.5 ± 0.1
Setesdal, Norway	October	Sheep	17.9 ± 0.1
Kvefjord, Norway	September	Sheep	10.7 ± 0.1
Kvefjord, Norway	September	Sheep	9.16 ± 0.09
Kvefjord, Norway	September	Sheep	11.1 ± 0.1
Kvefjord, Norway	September	Sheep	7.33 ± 0.1
Fiska, Norway	September	Sheep	34.1 ± 0.4
St. John's, Newfoundland	October	Sheep	64 ± 3
Palmer, Alaska	11/13	Calf (yearling)	4.4 ± 0.2
Alberta, Canada	August		26.2 ± 0.1
Agassiz, B. C., Canada	1/28	Sheep (yearling)	31.6 ± 1.5
Eagle, Alaska	10/5	Caribou (female)	50 ± 2
East Fork, Little Delta, Alaska	12/6	Caribou (male)	112 ± 4

Table 42—ANIMAL BONE ANALYZED AT THE UNIVERSITY OF CHICAGO

Sample No.	Date	Animal	Location	Sr ⁹⁰ , $\mu\mu\text{c/g Ca}$
United States				
CL 211	Jan. 1952	Steer	New Hampshire	0.44 ± 0.04
CL 212	Jan. 1952	Steer	New Hampshire	0.33 ± 0.02
CL 327	Spring 1953	Animal bone	Albany, N. Y.	3.26 ± 0.10
CL 104	Nov. 1953	Calf leg bone	Easton, N. Y.	3.71 ± 0.06
CL 105	Nov. 1953	Calf leg bone	Easton, N. Y.	3.76 ± 0.10
CL 326	Spring 1953	Calf bone	Tifton, Ga.	3.28 ± 0.12
CL 202	April 1954	Calf leg bone	Green Bay, Wisc.	0.71 ± 0.03
CL 176	Aug. 1953	Calf bone	Lewiston, Mont.	1.95 ± 0.04
CL 421	Dec. 1954	Lamb bone	Logan, Utah	2.51 ± 0.10
CL 422	Dec. 1954	Lamb bone	Logan, Utah	2.46 ± 0.09
CL 423	Dec. 1954	Lamb bone	Logan, Utah	2.76 ± 0.09
CL 424	Jan. 1955	Lamb bone	Logan, Utah	2.55 ± 0.08
CL 425	Jan. 1955	Lamb bone	Logan, Utah	2.62 ± 0.08
CL 426	Jan. 1955	Lamb bone	Logan, Utah	2.57 ± 0.07

Table 42 (Continued)

Sample No.	Date	Animal	Location	Sr ⁹⁰ , $\mu\text{C/g Ca}$
CL 427	Jan. 1955	Lamb bone	Logan, Utah	2.42 \pm 0.11
CL 428	Jan. 1955	Lamb bone	Logan, Utah	2.63 \pm 0.07
CL 813-P	Sept. 1955	Leg bone of Holstein-Angus	McHenry County, Ill.	0.51 \pm 0.03
CL 1012-P	Nov. 1955	Steer leg bones	Winnebago County, Ill.	2.09 \pm 0.11
CL 1011-P	Jan. 1956	Steer leg bones	Rock County, Wisc.	5.50 \pm 0.27
CL 841	Sept. 1955	Lamb bone	Cornell, N. Y.	4.45 \pm 0.34
CL 842	Sept. 1955	Lamb bone	Cornell, N. Y.	5.14 \pm 0.23
CL 843-P	Sept. 1955	Lamb bone	Cornell, N. Y.	6.98 \pm 0.34
CL 844-P	Sept. 1955	Lamb bone	Cornell, N. Y.	4.45 \pm 0.24
CL 972	Oct. 1955	Calf bone	Tifton, Ga.	12.9 \pm 0.6
CL 973	Oct. 1955	Calf bone	Tifton, Ga.	10.3 \pm 0.3
CL 974-P	Oct. 1955	Calf bone	Tifton, Ga.	12.7 \pm 0.7
CL 975-P	Oct. 1955	Calf bone	Tifton, Ga.	11.4 \pm 0.6
Foreign				
CL 180	Mar. 1954	Sheep	West coast of Norway	7.4 \pm 0.3
CL 181	Mar. 1954	Sheep	West coast of Norway	4.1 \pm 0.4
CL 182	Mar. 1954	Sheep	West coast of Norway	3.45 \pm 0.08
CL 329	Aug. 1954	Sheep	Hammerfest, Norway	1.97 \pm 0.09
CL 218	Apr. 1954	Sheep	E. Suffolk, England	1.97 \pm 0.05
CL 219	Apr. 1954	Sheep	E. Suffolk, England	1.82 \pm 0.07
CL 220	Apr. 1954	Sheep	E. Suffolk, England	1.15 \pm 0.03
CL 622	Feb. 1955	Sheep	Suffolk, England	31.4 \pm 0.6
CL 623	Feb. 1955	Sheep	Suffolk, England	13.1 \pm 0.2
CL 215	Apr. 1954	Sheep	Brecon, Wales	1.54 \pm 0.06
CL 216	Apr. 1954	Sheep	Montgomery, Wales	7.74 \pm 0.21
CL 217	Apr. 1954	Sheep	Cardigan, Wales	18.8 \pm 0.3
CL 624	Spring 1955	Sheep	Breconshire, Wales	5.2 \pm 0.3
CL 625	Spring 1955	Sheep	Cwmystwyth, Wales	60.6 \pm 1.2
CL 626	Spring 1955	Sheep	Lake Vyrnwy, Wales	18.3 \pm 0.4
CL 305	Aug. 1954	Lamb	Normandie, France	2.85 \pm 0.10
CL 464	Feb. 1955	Sheep	Paris, France	3.4 \pm 0.4
CL 183	Mar. 1954	Merino sheep	Rome, Italy	3.9 \pm 0.2
CL 184	Mar. 1954	Merino sheep	Rome, Italy	3.2 \pm 0.3
CL 185	Mar. 1954	Merino sheep	Rome, Italy	2.92 \pm 0.08
CL 456	Feb. 1955	Sheep	Italy	2.3 \pm 0.2
CL 457-P	Feb. 1955	Sheep	Italy	4.89 \pm 0.29
CL 186	Mar. 1954	Kirvircik sheep	Turkey	4.9 \pm 0.3
CL 187	Mar. 1954	Kirvircik sheep	Turkey	4.01 \pm 0.08
CL 188	Mar. 1954	Kirvircik sheep	Turkey	2.77 \pm 0.08
CL 194	Feb. 1954	Sheep	Damascus, Syria	0.9 \pm 0.1
CL 195	Feb. 1954	Sheep	Damascus, Syria	\leq 0.62
CL 189	Feb. 1954	Sheep	Beka Valley, Lebanon	0.40 \pm 0.06
CL 190	Feb. 1954	Sheep	Beka Valley, Lebanon	1.0 \pm 0.1
CL 191	Feb. 1954	Sheep	Boghari, Algeria	2.1 \pm 0.1
CL 192	Feb. 1954	Sheep	Boghari, Algeria	0.61 \pm 0.01
CL 1130-P	Early 1956	Lamb bones	Huancayo, Peru	7.48 \pm 0.44

Table 43—ANIMAL BONE SAMPLES ANALYZED AT LAMONT
GEOLOGICAL OBSERVATORY

Sample No.	Sampling date	Type	Location	Sr ⁹⁰ , μc/g Ca
North America				
B-2		Calf	Madison, Wisc.	1.16 ± 0.14
B-7		Animal	Albany, N. Y.	2.23 ± 0.14
B-84	Spring 1953	Animal	Tifton, Ga.	3.97 ± 0.50
B-85	Spring 1953	Animal	Albany, N. Y.	4.24 ± 0.28
B-3	August 1953*	Calf	Lewiston, Mont.	1.44 ± 0.08
B-5a	November 1953*	Calf	Easton, N. Y.	1.44 ± 0.08
Europe				
B-17	August 1954*	Calf	Oslo, Norway	0.17 ± 0.02
B-18	August 1954*	Calf	Rocheftort, France	0.54 ± 0.08
B-19	August 1954*	Sheep	Normandie, France	2.98 ± 0.08
B-20	August 1954*	Pig	Bremen, Germany	0.26 ± 0.04
B-21	August 1954*	Calf	Bremen, Germany	0.39 ± 0.04
B-22	August 1954*	Cow	Bremen, Germany	0.70 ± 0.06
B-23	August 1954*	Calf	Bordeaux, France	0.63 ± 0.10
B-47	August 1954*	Sheep	Hammerfest, Norway	2.65 ± 0.04
B-48	August 1954*	Calf	Hammerfest, Norway	0.83 ± 0.04
B-70	August 1954*	Polar bear skull	Spitsbergen Island	0.10 ± 0.02

*The date given is the date the sample was received.

Table 44—AVERAGE Sr⁹⁰ CONTENT IN MAN
(All values are given in micromicrocuries of strontium per gram of calcium, normalized to the whole skeleton. The figures in parentheses give the number of samples in the category.)

Location	Age at death (years)								20-80 (average)
	0-4	5-9	10-19	20-29	30-39	40-49	50-59	60-80	
July 1, 1955-June 30, 1956									
North									
America	0.56(10)	0.44(4)	0.20(13)	0.09(34)	0.07(38)	0.06(14)	0.04(17)	0.07(34)	0.070(137)
South									
America	0.33(12)	0.19(16)	0.14(26)	0.07(48)	0.06(58)	0.08(45)	0.07(18)	0.11(15)	0.073(184)
Europe	0.42(30)	0.27(19)	0.23(46)	0.06(70)	0.10(59)	0.06(8)	0.16(1)	0.09(3)	0.078(140)
Asia		0.10(2)	0.20(9)	0.06(35)	0.07(32)	0.11(11)	0.13(13)	0.20(4)	0.085(95)
Entire world	0.43(52)	0.25(41)	0.20(94)	0.068(187)	0.076(187)	0.079(78)	0.077(49)	0.091(56)	0.076(556)
World average 1955-56 = 0.15.									
July 1, 1956-June 30, 1957									
North									
America	0.67(30)	0.69(17)	0.38(15)	0.07(14)	0.06(9)	0.08(16)	0.05(5)	0.07(18)	0.070(62)
South									
America	0.16(3)	0.20(1)	0.19(5)	0.03(5)	0.02(2)	0.03(2)	0.06(3)	0.01(1)	0.034(13)
Europe	0.65(2)	0.34(4)	0.34(9)	0.06(20)	0.07(4)	0.04(6)	0.06(1)	0.08(2)	0.059(33)
Africa			0.06(2)	0.03(2)	0.03(3)	0.04(4)			0.035(9)
Asia	0.93(1)	0.12(2)	0.32(2)	0.06(8)	0.04(6)	0.12(8)	0.06(5)	0.05(5)	0.070(32)
Australia	0.75(3)	0.60(2)			0.03(3)	0.03(4)	0.03(3)		0.030(10)
Entire world	0.64(39)	0.57(26)	0.30(33)	0.059(49)	0.047(27)	0.070(40)	0.052(17)	0.065(26)	0.060(159)
World average 1956-57 = 0.20.									

Table 45—Sr⁹⁰ IN INFANT BONE ANALYZED AT THE UNIVERSITY OF CHICAGO
(Less than 30 days old)

Time interval	No. of individual samples	No. of composite samples	No. of individual samples in composite	Weighted mean, Sr ⁹⁰ /g Ca, μμc	Total Sr ⁹⁰ , μμc/g Ca		
					Total weighted mean, Sr ⁹⁰ /g Ca, μμc	Low High	
7/26/53-1/25/54	64	4	4, 30, 10, 5	0.152	0.115	0.043	0.4
				0.067		0.05	0.182
1/26/54-7/25/54		9	9, 10, 10, 10, 10, 4, 4, 3, 4	0.101	0.101	0.043	0.4
						0.060	0.160
7/26/54-9/4/54		1	10	0.160	0.160	0.060	0.160
						0.160	0.160

Table 46—Sr⁹⁰ IN MISCELLANEOUS INFANT BONE ANALYZED AT THE UNIVERSITY OF CHICAGO

Time interval	No. of individual samples	No. of composite samples	No. of individual samples in composite	Weighted mean, Sr ⁹⁰ /g Ca, μμc	Range, Sr ⁹⁰ /g Ca, μμc		
					Low	High	
New England							
9/15/53-9/28/53		1	4	0.31 ± 0.02			
3/8/55-4/8/55	2			0.40	0.35	0.45	
Utah							
3/8/54-4/4/54	2			0.221	0.19	0.252	
California							
10/30/54-11/18/54	4			0.161	0.078	0.38	
Japan							
3/5/54-8/7/54	6			0.149	0.082	0.30	
India							
12/24/53-1/3/54	3			0.043	0.04	0.05	
Chile							
7/20/55-8/18/55	11			0.449	0.049	1.2	
Lima, Peru							
7/4/55-9/10/55	9			0.694	0.2	2.16	

Table 47—Sr⁹⁰ IN HUMAN TEETH

	Ca in ash, %	Sr ⁹⁰ /g Ca, $\mu\mu\text{c}$	
Specimens Analyzed at HASL (Calcified 3–5 years ago, collected by Dr. L. Makta, New York)			
	29.5	0.79 ± 0.12	
	22.3	0.34 ± 0.10	
	27.4	0.48 ± 0.10	
Reference No.	Description	Ca in ash, %	Sr ⁹⁰ /g Ca, $\mu\mu\text{c}$
Specimens Analyzed at the University of Chicago (Collected during the summer of 1954 and furnished by Dr. S. Warren, Boston, Mass.)			
Group I	Primary dentition both sound and carious	37.8	0.038 ± 0.010
Group II	Both sound and carious teeth from children under 15 years	38.0	≤0.12
Group III	Carious teeth from children under 15 years	36.8	≤0.046
Group IV	Both sound and carious teeth from persons over 15 years	36.9	≤0.046
Group V	Carious teeth from persons over 15 years	36.8	≤0.006
Specimens from England (Furnished by Dr. S. Warren, Boston, Mass.)			
CL-159	Adult ages 18 to 35 years, London, Apr. and May 1950	35.6	0.014 ± 0.010
CL-400	Deciduous, Bristol, Oct. 1954 to Jan. 1955	37.9	≤0.10
CL-594	Deciduous, Bristol, Jan. to Apr. 1955	38.0	≤0.012
CL-665-P	Permanent teeth from persons over 15 years, Bristol, Jan. to Apr. 1955	38.7	0.026 ± 0.011

Table 48a—WHOLE-BODY Cs¹³⁷ CONTROLS, 1956
(Measured by the Los Alamos Scientific Laboratory)

Coding for 1956 Human Controls

Repeated measurements on individuals are tabulated by subject. The columns are:

1. Serial number
2. Subject weight in pounds
3. Subject age
4. K⁴⁰ gamma emission rate
5. K⁴⁰ specific activity in gamma rays per second per pound
6. Cs/K gamma ratio
7. Date of measurement

Serial No.	Weight, lb	Age	K ⁴⁰ , dis/sec	K ⁴⁰ /lb	Cs/K	Date	Serial No.	Weight, lb	Age	K ⁴⁰ , dis/sec	K ⁴⁰ /lb	Cs/K	Date
396	158	30	340	2.15	0.347	4/20	413	132	31	304	2.30	0.455	4/26
412	162	30	339	2.09	0.303	4/26	482	130	31	320	2.46	0.439	5/11
478	159	30	377	2.37	0.330	5/11	491	131	31	316	2.41	0.850	5/14
488	157	30	346	2.21	0.442	5/14	498	130	31	274	2.11	0.415	5/16
497	157	30	321	2.04	0.447	5/16	527	130	31	299	2.30	0.324	5/18
525	157	30	342	2.18	0.464	5/18	564	132	31	403	2.29	0.430	5/22
557	158	30	429	2.08	0.459	5/22	580	132	31	292	2.21	0.659	5/23
578	158	30	423	2.04	0.478	5/23	598	131	31	312	2.38	0.618	5/24
594	157	30	354	2.25	0.356	5/24	605	132	31	296	2.24	0.438	5/25
602	158	30	339	2.14	0.389	5/25	619	132	31	311	2.35	0.356	5/28
616	159	30	337	2.12	0.322	5/28	627	131	31	323	2.46	0.383	5/29
628	158	30	350	2.21	0.431	5/29	642	131	31	310	2.37	0.395	5/31
640	159	30	347	2.18	0.404	5/31	646	131	31	308	2.35	0.463	6/1
644	158	30	344	2.18	0.377	6/1	661	132	31	292	2.21	0.421	6/5
657	158	30	336	2.12	0.556	6/4	675	132	31	293	2.22	0.566	6/7
660	158	30	332	2.10	0.423	6/5	690	129	31	296	2.29	0.347	6/12
669	158	30	346	2.19	0.488	6/6	697	128	31	288	2.25	0.692	6/12
673	158	30	362	2.29	0.328	6/7	705	128	31	315	2.46	0.394	6/13
678	158	30	360	2.28	0.533	6/8	719	128	31	303	2.37	0.797	6/14
686	157	30	341	2.17	0.463	6/11	747	131	31	291	2.22	0.376	6/18
696	159	30	330	2.08	0.636	6/12	753	131	31	309	2.36	0.500	6/19
707	158	30	362	2.23	0.488	6/13	787	131	31	305	2.33	0.695	6/26
710	159	30	357	2.24	0.402	6/14	813	131	31	308	2.34	0.450	7/2
728	158	30	348	2.20	0.443	6/15	831	131	31	301	2.28	0.514	7/5
757	159	30	332	2.71	0.327	6/20	861	132	31	343	2.60	0.636	7/11
760	160	30	344	2.15	0.407	6/21	871	130	31	303	2.33	0.565	7/12
766	159	30	366	2.30	0.315	6/22	884	130	31	312	2.39	0.477	7/13
789	159	30	364	2.29	0.305	6/26	902	130	31	323	2.47	0.386	7/16
807	159	30	362	2.27	0.338	7/2	911	130	31	284	2.18	0.450	7/17
829	161	30	383	2.37	0.337	7/5	980	130	31	308	2.37	0.537	7/24
860	158	30	384	2.43	0.462	7/11	1033	130	31	283	2.18	0.386	7/27
869	158	30	376	2.37	0.540	7/12	1051	131	31	296	2.26	0.545	7/31
880	159	30	367	2.30	0.440	7/13	1085	132	31	304	2.30	0.472	8/3
901	159	30	311	2.59	0.478	7/16	1156	130	31	284	2.18	0.587	8/16
913	158	30	367	2.32	0.378	7/17	1172	131	31	313	2.39	0.288	8/21
982	160	30	343	2.14	0.530	7/24	1195	130	31	293	2.25	0.483	8/27
1000	160	30	331	2.07	0.400	7/25	1202	131	31	288	2.19	0.556	8/28
1029	158	30	355	2.24	0.443	7/27	1230	131	31	290	2.21	0.568	9/5
1040	160	30	367	2.29	0.396	7/30	1235	134	31	298	2.22	0.617	9/10
1068	160	30	348	2.17	0.463	8/1	1251	131	31	302	2.29	0.526	9/17
1087	160	30	390	2.43	0.265	8/3	1266	133	31	311	2.33	0.533	9/24
1116	159	30	356	2.24	0.612	8/7	1292	131	31	292	2.23	0.164	10/9
1139	159	30	344	2.16	0.217	8/13	1329	131	31	303	2.31	0.462	10/18
1155	159	30	331	2.07	0.486	8/16	1349	130	31	302	2.32	0.442	10/23
1179	160	30	335	2.09	0.442	8/21	1380	126	31	283	2.24	0.450	10/30
1199	158	30	352	2.22	0.599	8/28	1389	126	31	292	2.32	0.406	11/8
1225	158	30	358	2.27	0.440	9/5	1396	128	31	297	2.32	0.357	11/15
1242	158	30	339	2.15	0.373	9/11	1413	129	31	317	2.46	0.370	11/28
1254	159	30	379	2.38	0.452	9/18	1416	129	31	317	2.46	0.451	11/29
1268	156	30	336	2.15	0.576	9/26	305	166	31	420	2.53	0.230	4/3
1277	159	30	323	2.03	0.586	10/2	307	166	31	428	2.57	0.386	4/4
1291	158	30	347	2.19	0.401	10/9	309	166	31	427	2.57	0.292	4/5
1314	159	30	347	2.18	0.495	10/15	314	166	31	421	2.53	0.476	4/6
1353	158	30	351	2.22	0.474	10/23	440	168	31	392	2.33	0.460	5/5
1377	159	30	340	2.13	0.408	10/30	457	168	31	450	2.68	0.279	5/8
1398	158	30	343	2.17	0.458	11/15	461	168	31	437	2.60	0.349	5/9
1403	158	30	364	2.30	0.347	11/20	465	168	31	422	2.51	0.348	5/10
1409	159	30	375	2.36	0.382	11/27	495	167	31	453	2.71	0.240	5/14
1417	158	30	364	2.30	0.480	11/29	503	168	31	420	2.50	0.377	5/16
1430	158	30	342	2.17	0.287	12/6	519	168	31	446	2.65	0.327	5/17
312	133	31	302	2.27	0.484	4/6	533	167	31	417	2.50	0.364	5/18
395	130	31	288	2.21	0.428	4/20	563	156	31	402	2.42	0.296	5/22

Table 48a (Continued)

Serial No.	Weight, lb	Age	K ⁴⁰ , dis/sec	K ⁴⁰ /lb	Cs/K	Date	Serial No.	Weight, lb	Age	K ⁴⁰ , dis/sec	K ⁴⁰ /lb	Cs/K	Date
591	167	31	410	2.45	0.362	5/23	1009	154	32	463	3.01	0.331	7/25
608	168	31	422	2.51	0.300	5/25	1024	154	32	453	2.94	0.343	7/26
618	168	31	428	2.55	0.354	5/28	1052	154	32	471	3.06	0.308	7/31
632	168	31	418	2.48	0.313	5/29	1152	154	32	475	3.08	0.346	8/16
638	169	31	421	2.49	0.323	5/31	1174	154	32	400	2.60	0.499	8/21
663	168	31	434	2.58	0.399	6/5	1231	154	32	490	3.18	0.431	9/5
692	168	31	436	2.59	0.470	6/11	1245	154	32	479	3.11	0.379	9/12
706	168	31	432	2.57	0.433	6/13	1262	154	32	443	2.87	0.432	9/21
718	167	31	424	2.53	0.524	6/14	1270	154	32	464	3.01	0.358	9/27
723	168	31	427	2.54	0.454	6/15	1276	154	32	467	3.03	0.341	10/2
733	168	31	452	2.69	0.375	6/15	1309	154	32	472	3.06	0.479	10/12
738	169	31	436	2.58	0.418	6/18	1313	154	32	467	3.03	0.220	10/15
759	169	31	430	2.54	0.381	6/20	1365	151	32	494	3.27	0.408	10/25
762	169	31	432	2.56	0.367	6/21	1387	152	32	407	3.34	0.323	11/6
768	168	31	413	2.46	0.321	6/22	1416	150	32	486	3.24	0.338	11/29
804	168	31	422	2.51	0.307	6/29	1433	151	32	475	3.14	0.312	12/6
812	169	31	429	2.54	0.441	7/2	504	179	34	459	2.56	0.478	5/16
826	167	31	422	2.52	0.458	7/5	513	176	34	475	2.70	0.427	5/17
848	168	31	436	2.60	0.514	7/9	526	177	34	457	2.58	0.411	5/18
887	167	31	370	2.81	0.706	7/13	554	179	34	475	2.65	0.423	5/21
904	166	31	350	2.71	0.419	7/16	560	179	34	464	2.59	0.352	5/22
974	168	31	346	2.65	0.378	7/23	583	178	34	443	2.49	0.450	5/23
985	169	31	335	2.57	0.492	7/24	595	178	34	450	2.53	0.340	5/24
1054	168	31	317	2.48	0.518	7/31	603	179	34	460	2.57	0.410	5/25
1076	168	31	341	2.62	0.278	8/3	622	178	34	454	2.55	0.246	5/28
1098	168	31	345	2.65	0.301	8/7	631	177	34	460	2.60	0.319	5/29
1143	169	31	334	2.56	0.336	8/13	639	176	34	449	2.55	0.323	5/31
1157	169	31	334	2.57	0.405	8/16	689	181	34	456	2.52	0.380	6/11
1175	169	31	331	2.55	0.407	8/21	702	182	34	466	2.56	0.407	6/12
1193	168	31	429	2.65	0.404	8/27	720	180	34	484	2.69	0.485	6/14
1203	167	31	430	2.57	0.443	8/28	734	179	34	463	2.58	0.452	6/15
1215	168	31	432	2.57	0.282	8/31	745	181	34	454	2.51	0.413	6/18
1228	168	31	426	2.53	0.514	9/5	749	179	34	447	2.50	0.410	6/19
1243	168	31	446	2.65	0.433	9/11	778	178	34	433	2.43	0.429	6/25
1265	169	31	441	2.61	0.400	9/24	786	178	34	462	2.59	0.413	6/26
1275	168	31	416	2.48	0.467	10/1	830	178	34	446	2.50	0.484	7/5
1293	168	31	416	2.47	0.349	10/9	859	178	34	478	2.69	0.411	7/11
1319	168	31	417	2.48	0.468	10/17	867	179	34	466	2.60	0.546	7/12
1360	167	31	406	2.43	0.489	10/24	882	179	34	493	2.75	0.553	7/13
1388	166	31	427	2.57	0.358	11/6	895	177	34	475	2.68	0.402	7/16
1411	167	31	462	2.77	0.353	11/28	934	179	34	466	2.60	0.492	7/18
1415	167	31	440	2.63	0.446	11/29	983	179	34	446	2.49	0.491	7/24
1420	167	31	437	2.62	0.335	11/30	1006	179	34	468	2.61	0.481	7/25
1424	167	31	448	2.68	0.291	11/30	1023	179	34	448	2.50	0.402	7/26
1428	167	31	433	2.59	0.375	12/3	1030	179	34	428	2.39	0.497	7/27
1432	166	31	416	2.50	0.335	12/6	1232	179	34	461	2.57	0.585	9/5
308	155	32	468	3.02	0.347	4/5	1249	178	34	440	2.47	0.522	9/13
313	153	32	452	2.95	0.479	4/6	1278	182	34	460	2.52	0.320	10/3
406	154	32	479	3.11	0.314	4/21	1383	182	34	479	2.63	0.436	11/1
414	154	32	479	3.11	0.313	4/26	1410	183	34	448	2.45	0.431	11/27
423	154	32	503	3.26	0.216	5/2	415	149	35	406	2.72	0.404	4/26
430	154	32	400	2.59	0.476	5/3	420	148	35	441	2.98	0.379	5/2
438	154	32	472	3.06	0.355	5/4	429	146	35	423	2.89	0.583	5/3
458	154	32	483	3.13	0.270	4/8	437	146	35	404	2.77	0.619	5/4
469	154	32	491	3.18	0.350	5/11	441	147	35	416	2.83	0.489	5/7
492	154	32	496	3.23	0.309	5/14	459	145	35	396	2.73	0.448	5/8
566	154	32	477	3.09	0.321	5/22	460	144	35	404	2.80	0.516	5/9
581	154	32	481	3.12	0.332	5/23	466	144	35	410	2.85	0.596	5/10
597	154	32	483	3.13	0.331	5/24	470	144	35	447	3.10	0.338	5/11
604	154	32	474	3.08	0.363	5/25	493	146	35	414	2.83	0.491	5/14
621	154	32	481	3.12	0.220	5/28	502	144	35	389	2.70	0.622	5/16
633	154	32	486	3.16	0.334	5/29	516	145	35	364	2.51	0.618	5/17
691	154	32	464	3.01	0.401	6/11	532	145	35	427	2.94	0.502	5/18
735	154	32	525	3.40	0.402	6/18	546	145	35	415	2.80	0.569	5/19
744	154	32	471	3.05	0.375	6/18	553	145	35	489	2.68	0.602	5/21
752	154	32	493	3.20	0.130	6/19	562	145	35	497	2.73	0.646	5/22
764	154	32	481	3.12	0.390	6/21	577	146	35	412	2.82	0.630	5/23
767	154	32	454	2.95	0.361	6/22	600	147	35	394	2.65	0.636	5/24
811	154	32	490	3.18	0.390	7/2	611	146	35	404	2.77	0.663	5/25
827	154	32	470	3.05	0.378	7/5	623	147	35	398	2.71	0.435	5/28
844	154	32	490	3.18	0.518	7/9	626	147	35	410	2.70	0.607	5/29
963	153	32	476	3.76	0.153	7/16	656	147	35	403	2.74	0.470	6/4
933	154	32	477	3.10	0.412	7/18	687	149	35	411	2.76	0.571	6/11
981	154	32	494	3.20	0.445	7/24	699	147	35	396	2.69	0.675	6/12

Table 48a (Continued)

Serial No.	Weight, lb	Age	K ⁴⁰ , dis/sec	K ⁴⁰ /lb	Cs/K	Date	Serial No.	Weight, lb	Age	K ⁴⁰ , dis/sec	K ⁴⁰ /lb	Cs/K	Date
703	146	35	418	2.86	0.579	6/13	1178	212	40	511	2.41	0.401	8/21
717	147	35	420	2.86	0.588	6/14	1198	214	40	526	2.46	0.476	8/28
722	147	35	398	2.70	0.625	6/15	1248	213	40	527	2.47	0.371	9/13
731	149	35	402	2.70	0.530	6/15	1261	216	40	509	2.36	0.480	9/20
737	149	35	411	2.76	0.558	6/18	1279	218	40	523	2.39	0.353	10/3
750	148	35	401	2.71	0.593	6/19	1400	221	40	518	2.34	0.436	11/15
785	146	35	415	2.84	0.557	6/26	422	144	41	382	2.65	0.271	5/2
794	145	35	370	2.55	0.583	6/27	425	144	41	271	2.58	0.226	5/3
803	147	35	402	2.72	0.532	6/29	433	142	41	366	2.58	0.279	5/4
806	145	35	409	2.81	0.581	7/2	453	143	41	391	2.73	0.421	5/7
825	144	35	411	2.85	0.659	7/5	456	144	41	381	2.64	0.320	5/8
836	145	35	403	2.76	0.686	7/6	463	143	41	362	2.53	0.504	5/10
842	145	35	409	2.82	0.278	7/9	468	143	41	391	2.74	0.342	5/11
855	144	35	387	3.38	0.734	7/10	490	143	41	379	2.65	0.291	5/14
870	145	35	403	3.47	0.639	7/12	500	143	41	364	2.55	0.337	5/16
878	144	35	454	3.15	0.881	7/13	512	143	41	395	2.76	0.360	5/17
891	143	35	396	2.77	0.518	7/16	524	143	41	397	2.77	0.241	5/18
912	143	35	428	2.99	0.651	7/17	559	143	41	464	2.54	0.339	5/22
972	142	35	402	2.82	0.652	7/23	579	142	41	358	2.52	0.419	5/23
978	141	35	432	3.06	0.792	7/24	592	142	41	366	2.57	0.313	5/24
1017	143	35	424	2.97	0.649	7/26	606	141	41	363	2.57	0.346	5/25
1041	141	35	421	2.98	0.576	7/30	617	141	41	369	2.62	0.369	5/28
1075	143	35	415	2.90	0.572	8/3	810	144	41	369	2.56	0.361	7/2
1090	142	35	419	2.95	0.578	8/6	823	142	41	366	2.57	0.384	7/5
1142	142	35	392	2.76	0.581	8/13	858	142	41	398	2.79	0.567	7/11
1173	140	35	395	2.82	0.561	8/21	885	144	41	404	2.81	0.587	7/13
1192	139	35	380	2.73	0.523	8/27	894	142	41	384	2.70	0.434	7/16
1226	143	35	399	2.79	0.593	9/5	931	143	41	369	2.58	0.409	7/18
1241	142	35	394	2.77	0.545	9/11	979	142	41	376	2.65	0.385	7/24
1255	141	35	393	2.78	0.810	9/18	1015	142	41	385	2.71	0.346	7/26
1267	141	35	390	2.77	0.680	9/24	1028	141	41	383	2.71	0.637	7/27
1295	142	35	403	2.83	0.461	10/11	1042	142	41	368	2.59	0.497	7/30
1318	143	35	390	2.71	0.480	10/17	1153	141	41	388	2.75	0.467	8/16
1330	143	35	391	2.73	0.653	10/18	1177	142	41	379	2.66	0.325	8/21
1381	144	35	414	2.87	0.577	11/1	1200	140	41	358	2.55	0.570	8/28
1404	144	35	385	2.67	0.629	11/20	1213	141	41	358	2.54	0.308	8/31
1408	146	35	433	2.96	0.479	11/27	1227	141	41	375	2.66	0.848	9/5
1412	144	35	418	2.90	0.401	11/28	1258	140	41	384	2.73	0.275	9/20
1414	144	35	385	2.67	0.649	11/28	1271	141	41	362	2.57	0.289	9/27
1425	144	35	441	3.06	0.491	12/3	1285	141	41	354	2.51	0.237	10/5
1426	144	35	380	3.33	0.521	12/3	1296	142	41	368	2.59	0.561	10/11
1427	144	35	415	2.88	0.393	12/3	1332	142	41	357	2.51	0.465	10/19
1434	142	35	388	2.73	0.572	12/6	1370	142	41	387	2.72	0.375	10/26
419	211	40	657	3.11	0.174	5/2	1379	142	41	348	2.45	0.701	10/30
477	220	40	642	2.91	0.730	5/11	1401	138	41	353	2.56	0.312	11/15
496	213	40	607	2.85	0.285	5/14	1435	141	41	363	2.57	0.413	12/6
499	213	40	523	2.45	0.387	5/16	424	127	45	378	2.98	0.446	5/2
517	213	40	593	2.78	0.226	5/17	494	124	45	405	3.26	0.403	5/14
531	213	40	536	2.51	0.375	5/18	505	127	45	374	2.95	0.550	5/16
561	212	40	439	2.54	0.357	5/22	515	127	45	395	3.11	0.463	5/17
576	210	40	516	2.46	0.377	5/23	528	127	45	381	3.00	0.525	5/18
596	212	40	516	2.43	0.373	5/24	565	127	45	397	3.12	0.480	5/22
607	212	40	522	2.46	0.365	5/25	584	126	45	371	2.95	0.478	5/23
615	211	40	538	2.55	0.415	5/28	599	125	45	391	3.12	0.398	5/24
629	210	40	528	2.51	0.323	5/29	609	125	45	365	2.92	0.423	5/25
641	211	40	549	2.60	0.396	5/31	620	125	45	381	3.04	0.327	5/28
667	213	40	527	2.47	0.405	6/5	634	125	45	378	3.02	0.502	5/29
671	212	40	555	2.62	0.351	6/6	659	125	45	360	2.88	0.498	6/4
674	212	40	557	2.63	0.350	6/7	662	125	45	369	2.95	0.474	6/5
688	215	40	531	2.47	0.415	6/11	668	125	45	383	3.06	0.508	6/6
700	213	40	518	2.43	0.397	6/12	694	125	45	384	3.07	0.593	6/11
727	213	40	531	2.49	0.362	6/15	701	125	45	390	3.12	0.555	6/12
758	217	40	509	2.34	0.420	6/20	755	125	45	376	3.00	0.423	6/19
784	210	40	546	2.60	0.457	6/25	816	127	45	376	2.96	0.432	7/2
793	209	40	553	2.65	0.377	6/26	832	125	45	370	2.96	0.585	7/5
814	208	40	543	2.61	0.227	7/2	853	126	45	412	3.27	0.646	7/11
828	209	40	525	2.51	0.372	7/5	886	127	45	390	3.07	0.846	7/13
879	208	40	652	3.13	0.636	7/13	899	126	45	376	2.98	0.448	7/16
893	208	40	547	2.63	0.210	7/16	918	126	45	396	3.14	0.531	7/17
986	209	40	533	2.55	0.372	7/24	932	129	45	404	2.35	0.367	7/18
1013	211	40	558	2.64	0.216	7/26	984	126	45	374	2.97	0.470	7/24
1039	212	40	523	2.46	0.352	7/30	1005	127	45	378	2.97	0.470	7/25
1159	212	40	509	2.40	0.287	8/16	1022	127	45	382	3.01	0.417	7/26

Table 48a (Continued)

Serial No.	Weight, lb	Age	K^{40} , dis/sec	K^{40} /lb	Cs/K	Date	Serial No.	Weight, lb	Age	K^{40} , dis/sec	K^{40} /lb	Cs/K	Date
1045	126	45	361	2.87	0.576	7/30	746	146	30	365	2.50	0.372	6/18
1141	127	45	373	2.93	0.607	8/13	751	147	30	394	2.68	0.317	6/19
1180	127	45	379	2.99	0.474	8/21	756	147	30	380	2.58	0.266	6/20
1218	126	45	384	3.03	0.409	8/31	761	148	30	378	2.55	0.427	6/21
1239	125	45	370	2.96	0.399	9/10	769	148	30	381	2.57	0.311	6/22
1263	126	45	369	2.93	0.448	9/21	779	146	30	374	2.56	0.319	6/25
1294	127	45	374	2.94	0.495	10/9	788	148	30	368	2.48	0.328	6/26
1321	127	45	369	2.91	0.514	10/17	809	147	30	379	2.57	0.385	7/2
1392	125	45	383	3.06	0.826	11/9	824	147	30	369	2.50	0.357	7/5
1437	127	45	416	2.49	0.711	12/6	843	149	30	380	2.55	0.490	7/9
421	145	30	359	2.48	0.314	5/2	881	146	30	391	2.67	0.452	7/13
427	148	30	251	2.37	0.397	5/3	1001	148	30	381	2.57	0.394	7/25
434	148	30	361	2.44	0.322	5/4	1014	148	30	367	2.48	0.446	7/26
452	147	30	380	2.58	0.461	5/7	1027	147	30	379	2.58	0.398	7/27
455	148	30	382	2.58	0.304	5/8	1043	147	30	369	2.50	0.442	7/30
464	147	30	363	2.47	0.479	5/10	1077	149	30	383	2.57	0.446	8/3
467	147	30	373	2.54	0.304	6/11	1117	147	30	367	2.49	0.324	8/7
489	149	30	384	2.57	0.294	5/14	1160	148	30	361	2.43	0.428	8/16
501	148	30	355	2.40	0.326	5/16	1176	149	30	334	2.23	0.353	8/21
511	147	30	381	2.59	0.303	5/17	1201	149	30	386	2.59	0.450	8/28
558	150	30	458	2.38	0.335	5/22	1214	147	30	366	2.48	0.151	8/31
582	149	30	367	2.46	0.383	5/23	1229	147	30	387	2.62	0.257	9/5
593	147	30	361	2.45	0.383	5/24	1244	149	30	363	2.44	0.420	9/12
601	148	30	357	2.41	0.445	5/25	1260	149	30	384	2.58	0.458	9/20
614	150	30	380	2.53	0.410	5/28	1284	147	30	360	2.45	0.445	10/4
643	148	30	369	2.49	0.308	6/1	1297	143	30	382	2.66	0.287	10/12
693	148	30	383	2.59	0.453	6/11	1320	145	30	349	2.41	0.458	10/17
695	146	30	372	2.54	0.477	6/12	1382	143	30	362	2.53	0.305	11/1
704	146	30	379	2.60	0.409	6/13	1390	142	30	334	2.35	0.428	11/8
732	147	30	393	2.68	0.324	6/15	1402	143	30	359	2.51	0.398	11/15
							1436	148	30	358	2.42	0.332	12/4

Table 48b—WHOLE-BODY Cs¹³⁷ DETERMINATIONS, 1956
(Measured at the Los Alamos Scientific Laboratory)

Coding for 1956 General Whole Body Measurements

Single measurements on individuals, listed in chronological order of measurement, are given. The columns are:

1. Serial number
2. Sex
3. Subject weight in pounds
4. Age of subject
5. Home state of subject
6. K⁴⁰ activity in gamma emissions per second
7. K⁴⁰ specific activity in gamma rays per second per pound
8. Cs/K gamma ratio
9. Date of measurement

Serial No.	Sex	Weight, lb	Age	State	K ⁴⁰ , dis/sec	K ⁴⁰ /lb	Cs/K	Date
217	M	162	24	N. Mex.	611	3.77	0.397	3/6
218	M	176	27	USAF	510	2.90	0.332	3/6
219	M	168	34	N. Mex.	477	2.84	0.378	3/6
220	M	174	34	N. Mex.	567	3.26	0.164	3/6
221	M	159	31	N. Mex.	436	2.74	0.359	3/7
222	M	199	33	N. Mex.	496	2.49	0.166	3/7
234	M	177	32	N. Mex.	451	2.55	0.607	3/12
242	M	156	36	Utah	446	2.86	0.485	3/12
248	M	177	38	N. Mex.	464	2.62	0.302	3/13
249	F	116	34	N. Mex.	283	2.44	0.235	3/14
252	F	115	43	N. Mex.	273	2.38	0.499	3/14
253	F	144	31	N. Mex.	337	2.34	0.371	3/14
254	F	071	10	N. Mex.	207	2.92	0.523	3/14
256	M	145	38	Ark.	443	3.06	0.757	3/15
257	M	145	36	Ark.	434	2.99	0.505	3/15
258	M	182	50	N. Mex.	455	2.50	0.323	3/15
263	M	157	49	N. Mex.	365	2.33	0.439	3/16
264	M	054	06	N. Mex.	138	2.57	0.520	3/17
267	F	108	47	N. Mex.	289	2.67	0.231	3/19
268	M	123	14	N. Mex.	381	3.09	0.205	3/19
276	M	161	37	N. Mex.	430	2.67	0.348	3/21
289	M	190	34	Va.	436	2.29	0.374	3/26
290	M	172	29	Va.	523	3.04	0.494	3/26
291	M	139	30	Va.	473	3.40	0.584	3/26
297	M	152	30	Ark.	459	3.02	0.370	3/27
298	M	192	28	Ark.	415	2.16	0.421	3/27
302	F	109	28	N. Mex.	274	2.51	0.428	4/2
303	M	126	29	Texas	352	2.79	0.280	4/3
315	M	177	39	Ind.	460	2.60	0.579	4/6
316	M	149	39	N. Mex.	401	2.69	0.488	4/6
317	M	180	36	N. Mex.	458	2.54	0.269	4/6
398	M	139	35	Va.	432	3.11	0.471	4/21
399	M	176	28	Va.	565	3.21	0.528	4/21
400	M	041	05	N. Mex.	120	2.96	0.606	4/21
401	M	070	10	N. Mex.	253	3.61	0.445	4/21
407	M	077	08	N. Mex.	178	2.33	0.413	4/22
408	M	056	08	N. Mex.	155	2.77	0.406	4/22
409	F	144	31	N. Mex.	302	2.10	0.358	4/23
431	M	205	33	Va.	548	2.67	0.345	5/4
436	F	108	28	N. Mex.	216	2.00	0.779	5/4

Table 48b (Continued)

Serial No.	Sex	Weight, lb	Age	State	K^{40} , dis/sec	K^{40} /lb	Cs/K	Date
439	M	166	36	N. Mex.	487	2.93	0.306	5/5
506	F	153	27	N. Mex.	397	2.60	0.328	5/16
522	M	168	36	Ark.	422	2.51	0.518	5/17
523	M	159	30	Ark.	494	3.11	0.529	5/17
534	F	137	25	N. Mex.	280	2.04	0.373	5/19
535	F	151	31	N. Mex.	319	2.11	0.456	5/19
536	F	123	37	N. Mex.	328	2.67	0.281	5/19
537	F	138	36	N. Mex.	240	1.74	0.599	5/19
538	F	132	48	N. Mex.	218	1.65	0.244	5/19
539	F	131	45	N. Mex.	258	1.97	0.510	5/19
540	F	113	50	Colo.	231	2.05	0.736	5/19
541	F	164	53	Colo.	330	2.01	0.637	5/19
542	F	103	23	N. Mex.	257	2.49	0.507	5/19
543	F	116	45	N. Mex.	221	1.90	0.253	5/19
545	F	152	48	N. Mex.	279	1.83	0.449	5/19
555	M	130	29	Ark.	421	3.24	0.523	5/21
556	M	168	31	Ark.	433	2.58	0.395	5/21
570	M	164	34	Va.	376	2.29	0.555	5/22
571	M	139	37	Va.	424	3.05	0.539	5/22
573	M	164	32	Va.	431	2.63	0.547	5/22
574	M	177	32	Va.	453	2.56	0.435	5/22
575	M	185	32	Va.	476	2.57	0.597	5/22
613	F	115	40	N. Mex.	266	2.31	0.660	5/25
652	F	126	31	N. Mex.	268	2.12	0.451	6/1
655	M	540	06	N. Mex.	100	1.87	0.351	6/3
664	M	169	38	N. Mex.	389	2.30	0.438	6/5
665	M	188	33	Ark.	442	2.35	0.573	6/5
666	M	210	31	Ark.	578	2.75	0.499	6/5
670	M	177	31	N. Mex.	456	2.57	0.784	6/6
679	M	192	31	N. Mex.	669	3.48	0.392	6/8
680	F	126	25	N. Mex.	349	2.77	0.413	6/8
681	F	105	24	N. Mex.	245	2.33	0.659	6/8
709	M	170		N. Mex.	321	1.88	0.501	6/13
725	M	137	35	N. Mex.	429	3.13	0.976	6/15
739	M	167	27	USAF	477	3.40	0.712	6/18
740	M	172	32	USAF	467	2.72	0.558	6/18
741	M	135	28	USAF	367	2.71	0.491	6/18
742	M	130	30	USAF	425	3.27	0.552	6/18
743	M	185	30	USAF	499	2.69	0.443	6/18
748	M	139	50	N. Mex.	387	2.78	0.373	6/18
754	F	094	36	N. Mex.	205	2.18	0.302	6/19
763	M	164	22	Colo.	443	2.70	0.231	6/21
770	F	107	28	N. Mex.	257	2.40	0.497	6/22
771	M	186	43	Ohio	468	2.51	0.479	6/22
774	F	117	30	N. Mex.	258	2.21	0.365	6/22
775	F	141	50	Ill.	287	2.03	0.450	6/22
777	M	162	29	USAF	456	2.81	0.742	6/25
780	M	155	31	USAF	487	3.14	0.244	6/25
782	M	155	27	USAF	438	2.82	0.452	6/25
783	M	174	27	USAF	520	2.98	0.596	6/25
791	F	121	14	Tenn.	288	2.38	0.394	6/26
792	F	089	12	Ohio	242	2.72	0.374	6/26
795	M	128	21	Pa.	359	2.80	0.657	6/27
796	M	163	29	Mich.	456	2.80	0.554	6/27

Table 48b (Continued)

Serial No.	Sex	Weight, lb	Age	State	K ⁴⁰ , dis/sec	K ⁴⁰ /lb	Cs/K	Date
797	M	070	11	Colo.	207	2.96	0.503	6/28
798	F	108	28	N. Mex.	228	2.10	0.442	6/28
808	M	178	40	Calif.	536	3.00	0.149	7/2
817	M	200	56	Tenn.	428	2.14	0.447	7/2
818	M	036	03	N. Mex.	097	2.75	0.512	7/2
819	F	041	05	Calif.	114	2.77	0.923	7/2
820	F	047	06	Calif.	149	3.20	0.438	7/2
821	F	081	07	Calif.	210	2.59	0.381	7/2
822	F	176	31	Calif.	381	2.16	0.353	7/2
835	F	111	21	Ill.	273	2.46	0.557	7/6
837	M	181	25	USAF	640	3.53	0.422	7/9
838	M	204	33	USAF	522	2.56	0.564	7/9
839	M	163	30	USAF	486	2.98	0.350	7/9
840	M	156	30	USAF	479	3.07	0.575	7/9
841	M	145	31	USAF	434	2.98	0.620	7/9
846	M	144	30	N. Mex.	457	3.16	0.627	7/9
850	M	175	30	N. Mex.	580	3.31	0.686	7/10
851	F	132	16	N. Y.	347	2.63	0.844	7/10
852	F	101	35	N. Mex.	343	3.38	0.620	7/10
853	M	215	42	Calif.	605	2.81	0.225	7/10
854	M	210	34	Ill.	450	2.14	0.510	7/10
856	M	164	50	N. Mex.	521	3.18	0.806	7/11
864	M	164	39	USAF	434	2.65	0.594	7/12
865	M	175	38	USAF	578	3.30	0.327	7/12
888	M	165	40	Kans.	450	2.72	0.650	7/13
890	F	141	57	N. J.	315	2.24	0.775	7/13
898	F	134	32	N. Mex.	288	2.14	0.456	7/16
900	M	124	22	N. Mex.	388	3.12	0.353	7/16
914	M	181	35	Calif.	470	2.59	0.253	7/17
915	M	134	14	Ala.	424	3.16	0.526	7/17
916	M	081	12	N. Mex.	269	3.33	0.792	7/17
917	M	190	27	N. Mex.	482	2.53	0.508	7/17
919	M	179	24	N. Mex.	505	2.82	0.580	7/17
921	M	140	44	Iowa	409	2.91	0.369	7/18
922	M	188	43	Iowa	480	2.55	0.538	7/18
923	M	230	40	Ill.	551	2.39	0.367	7/18
924	M	192	32	Iowa	487	2.54	0.468	7/18
925	M	172	43	N. Mex.	405	2.35	0.493	7/18
927	M	100	11	Ill.	259	2.59	0.455	7/18
928	F	117	45	Ill.	266	2.27	0.305	7/18
929	F	151	46	Ohio	281	1.86	0.767	7/18
936	M	120	16	Ill.	383	3.18	0.482	7/18
937	F	180	52	N. Mex.	336	1.87	0.597	7/18
943	F	120	33	Ariz.	286	2.38	0.622	7/19
944	F	134	26	N. Mex.	291	2.17	0.782	7/19
945	F	113	52	Idaho	251	2.22	0.478	7/19
946	M	200	64	Idaho	465	2.32	0.462	7/19
947	F	114	26	N. Mex.	256	2.25	0.521	7/19
948	F	155	25	N. Mex.	336	2.17	0.606	7/19
949	F	143	29	N. Mex.	314	2.19	0.570	7/19
950	F	135	60	Mass.	229	1.69	0.559	7/19
951	F	150	61	Ohio	270	1.79	0.522	7/19
952	F	135	65	Ohio	251	1.85	0.485	7/19
953	F	172	63	Mo.	298	1.73	0.556	7/19

Table 48b (Continued)

Serial No.	Sex	Weight, lb	Age	State	K ⁴⁰ , dis/sec	K ⁴⁰ /lb	Cs/K	Date
954	F	166	24	Ohio	355	2.13	0.793	7/19
955	M	203	27	Ohio	475	2.34	0.842	7/19
957	F	121	41	N. Y.	222	1.83	0.767	7/20
958	F	113	44	D. C.	233	2.06	0.741	7/20
959	F	139	26	N. Mex.	299	2.15	0.804	7/20
960	M	166	25	N. Mex.	434	2.60	0.500	7/20
961	M	219	21	N. Mex.	554	2.53	0.474	7/20
962	F	120	20	Colo.	262	2.18	0.571	7/20
963	F	090	22	Texas	226	2.51	0.745	7/20
964	F	137	19	Ill.	270	1.97	0.802	7/20
966	M	080	09	N. Mex.	218	2.73	0.200	7/21
967	M	054	07	N. Mex.	181	3.36	0.137	7/21
968	M	104	27	Ill.	261	2.51	0.691	7/21
969	M	061	08	Ill.	204	3.34	0.997	7/21
970	M	034	03	N. Mex.	139	4.10	0.946	7/22
971	F	118	30	N. Mex.	312	2.64	0.843	7/22
973	M	177	20	Mass.	566	3.19	0.790	7/23
975	M	165	48	Calif.	453	2.75	0.380	7/23
976	F	112	12	Calif.	278	2.48	0.793	7/23
977	M	145	18	Texas	433	2.99	0.583	7/23
987	M	080	09	N. Mex.	196	2.45	0.608	7/24
988	F	117	30	N. Mex.	282	2.41	0.494	7/24
989	M	054	07	N. Mex.	161	2.99	0.753	7/24
990	M	060	08	Ill.	165	2.76	0.774	7/24
991	F	105	27	Ill.	249	2.37	0.542	7/24
992	M	121		Ill.	401	3.31	0.365	7/24
993	F	132	60	Ill.	246	1.86	0.516	7/24
994	F	127	64	Oreg.	245	1.93	0.784	7/24
995	F	159	38	Texas	256	1.61	0.276	7/24
996	M	155	60	Oreg.	356	2.30	0.758	7/24
997	M	151	66	Ill.	327	2.17	0.584	7/24
998	M	191	32	N. Mex.	484	2.53	0.333	7/24
999	M	178	45	N. Mex.	491	2.76	0.400	7/24
1002	M	096	10	N. Mex.	226	2.35	0.802	7/25
1007	M	160	80	Iowa	313	1.95	0.503	7/25
1008	M	045	07	N. Mex.	181	4.02	0.740	7/25
1010	F	115	37	Ill.	272	2.37	0.769	7/25
1016	F	135	32	N. Mex.	348	2.57	0.598	7/26
1018	M	188	37	Wash.	543	2.88	0.307	7/26
1019	M	149	24	N. Mex.	518	3.47	0.362	7/26
1020	M	114	15	N. Mex.	342	3.00	0.517	7/26
1021	M	139	14	N. Mex.	412	2.96	0.570	7/26
1025	F	160	17	Ala.	354	2.21	0.583	7/26
1026	M	195	34	N. Mex.	528	2.70	0.723	7/26
1031	F	123	29	N. Mex.	338	2.75	0.622	7/27
1032	F	054	09	Mont.	165	3.03	0.336	7/27
1034	M	060	07	Mont.	152	2.53	0.843	7/27
1035	F	122	35	Mont.	231	1.89	0.581	7/27
1036	F	030	03	Mont.	084	2.79	0.115	7/27
1046	F	105	42	Mo.	242	2.30	0.301	7/30
1047	F	111	16	Mo.	303	2.72	0.447	7/31
1048	F	124	17	Mo.	323	2.60	0.509	7/31
1049	M	078	11	Mo.	219	2.79	0.613	7/31
1050	F	134	62	Ohio	272	2.03	0.599	7/31

Table 48b (Continued)

Serial No.	Sex	Weight, lb	Age	State	K^{40} , dis/sec	K^{40} /lb	Cs/K	Date
1053	M	176	20	N. J.	540	3.07	0.691	7/31
1057	F	102	21	N. Mex.	240	2.36	0.316	8/1
1058	F	129	21	Oreg.	337	2.61	0.501	8/1
1059	F	134	16	Ill.	296	2.21	0.459	8/1
1060	M	145	30	N. Mex.	391	2.70	0.280	8/1
1061	M	153	65	Texas	390	2.55	0.289	8/1
1062	M	202	31	N. Mex.	501	2.48	0.510	8/1
1063	M	189	58	N. Mex.	437	2.31	0.374	8/1
1064	F	123	47	D. C.	284	2.31	0.778	8/1
1065	F	117	16	Mass.	275	2.35	0.781	8/1
1066	F	096	12	D. C.	251	2.62	0.950	8/1
1067	F	128	16	D. C.	335	2.60	0.793	8/1
1069	F	066	10	D. C.	209	3.16	0.548	8/1
1072	M	256	32	Iowa	583	2.28	0.525	8/2
1079	M	145	39	Ohio	399	2.75	0.344	8/3
1080	F	147	20	N. Mex.	287	1.95	0.621	8/3
1081	M	165	20	N. Y.	498	3.02	0.568	8/3
1083	M	065	10	N. Mex.	199	3.07	0.527	8/3
1086	M	167	46	N. Mex.	466	2.79	0.292	8/3
1088	F	123	14	N. Mex.	282	2.29	0.391	8/3
1089	F	120	47	N. Mex.	270	2.25	0.417	8/3
1091	M	186	28	N. Mex.	574	3.09	0.512	8/6
1092	M	189	31	USAF	518	2.74	0.483	8/6
1093	M	176	26	USAF	484	2.75	0.648	8/6
1094	M	185	28	USAF	447	2.41	0.377	8/6
1095	M	160	25	USAF	493	3.08	0.362	8/6
1096	M	166	28	USAF	530	3.19	0.437	8/6
1097	F	141	17	Minn.	326	2.31	0.688	8/6
1099	M	172	43	Pa.	433	2.52	0.454	8/7
1100	M	071	10	Pa.	212	2.96	0.149	8/7
1101	F	141	39	Pa.	282	2.00	0.675	8/7
1105	F	146	43	Minn.	301	2.06	0.762	8/6
1106	F	051	09	Minn.	179	3.48	0.804	8/6
1104	F	129	52	La.	273	2.62	0.729	8/7
1107	F	050	07	N. Mex.	133	2.66	0.722	8/6
1108	M	186	26	N. Mex.	608	3.27	0.810	8/6
1110	M	154	26	N. Mex.	436	2.83	0.640	8/7
1111	F	117	17	La.	329	2.81	0.419	8/7
1112	M	161	30	Ill.	435	2.70	0.476	8/7
1118	F	111	25	Ill.	283	2.55	0.457	8/8
1120	M	172	40	Colo.	489	2.84	0.277	8/8
1121	M	213	41	Colo.	551	2.58	0.444	8/8
1122	M	163	39	N. Mex.	435	2.67	0.292	8/13
1123	M	161	43	N. Mex.	436	2.71	0.238	8/13
1124	M	157	28	N. Mex.	382	2.42	0.845	8/13
1125	M	124	28	N. Mex.	283	2.27	0.528	8/13
1126	M	169	55	N. Mex.	424	2.51	0.007	8/13
1127	M	192	52	N. Mex.	433	2.24	0.387	8/13
1128	M	141	25	N. Mex.	382	2.71	0.408	8/13
1129	M	164	30	N. Mex.	407	2.48	0.519	8/13
1130	F	176	47	N. Mex.	316	1.79	0.360	8/13
1131	F	125	46	N. Mex.	207	1.66	0.398	8/13
1132	M	158	42	N. Mex.	475	3.00	0.332	8/13
1133	M	172	41	N. Mex.	417	2.41	0.499	8/13
1134	M	126	35	N. Mex.	373	2.96	0.490	8/13

Table 48b (Continued)

Serial No.	Sex	Weight, lb	Age	State	K ⁴⁰ , dis/sec	K ⁴⁰ /lb	Cs/K	Date
1135	M	166	31	N. Mex.	397	2.39	0.571	8/13
1136	M	197	33	N. Mex.	577	2.92	0.369	8/13
1137	M	205	34	N. Mex.	522	2.55	0.525	8/13
1140	M	203	24	Mo.	562	2.77	0.364	8/13
1147	M	117	16	Texas	392	3.35	0.253	8/15
1148	M	184	66	Texas	451	2.45	0.216	8/15
1150	M	187	00	D. C.	447	2.39	0.416	8/15
1151	M	136	00	D. C.	454	3.32	0.414	8/15
1158	F	146	60	Calif.	241	1.65	0.899	8/16
1161	M	189	27	N. Mex.	482	2.54	0.390	8/17
1162	F	139	47	Calif.	291	2.09	0.426	8/17
1163	F	137	50	Calif.	250	1.82	0.637	8/17
1164	M	104	13	Calif.	285	2.72	0.148	8/17
1165	M	226	55	Calif.	507	2.23	0.306	8/17
1166	M	138	41	Ill.	375	2.71	0.461	8/17
1167	M	046	07	N. Mex.	108	2.34	0.911	8/17
1168	M	122	14	N. Mex.	365	2.99	0.700	8/17
1169	M	136	37	N. Mex.	331	2.43	0.532	8/17
1184	M	182	43	Ind.	434	2.38	0.490	8/23
1185	F	060	11	N. Mex.	180	2.97	0.842	8/23
1186	F	132	40	N. Mex.	281	2.12	0.669	8/23
1187	M	137	14	N. Mex.	418	3.04	0.514	8/23
1188	M	101	12	N. Mex.	276	2.71	0.884	8/23
1189	M	169	41	Ark.	432	2.55	0.492	8/24
1190	M	154	41	Ala.	441	2.86	0.518	8/24
1191	M	169	49	Mass.	446	2.63	0.405	8/25
1194	F	129	49	Minn.	273	2.11	0.642	8/27
1196	F	159	33	Ky.	292	1.83	0.362	8/27
1197	F	122	30	Ky.	287	2.35	0.533	8/27
1204	M	163	20	USN	424	2.59	0.567	8/28
1205	M	149	24	N. Mex.	382	2.56	0.495	8/28
1206	M	197	30	Ga.	457	2.32	0.582	8/29
1207	M	174	27	N. Mex.	536	3.07	0.407	8/29
1208	M	156	36	N. Mex.	435	2.77	0.338	8/30
1209	M	149	23	Oreg.	386	2.58	0.432	8/30
1210	M	140	44	N. Mex.	363	2.59	0.566	8/30
1211	F	181	61	Kans.	347	1.91	0.309	8/30
1212	M	188	61	Kans.	438	2.33	0.381	8/30
1216	M	135	43	Okla.	411	3.03	0.342	8/31
1217	F	135	40	Okla.	285	2.10	0.362	8/31
1218	F	073	08	N. Mex.	173	2.38	0.552	9/2
1219	F	059	10	N. Mex.	173	2.95	0.197	9/2
1220	M	058	07	N. Mex.	160	2.79	0.204	9/2
1221	F	125	24	N. Mex.	303	2.42	0.419	9/3
1224	F	103	19	Mo.	261	2.52	0.242	9/4
1233	M	142	26	Iowa	394	2.78	0.510	9/6
1234	M	168	65	R. I.	388	2.31	0.941	9/7
1236	M	175	36	D. C.	451	2.58	0.440	9/10
1237	M	216	35	USAF	512	2.37	0.466	9/10
1238	M	165	34	N. Y.	458	2.77	0.566	9/10
1240	M	163	35	Mass.	445	2.73	0.708	9/10
1246	M	172	32	N. Mex.	474	2.75	0.478	9/12
1247	M	150	27	N. Mex.	419	2.79	0.339	9/12

Table 48b (Continued)

Serial No.	Sex	Weight, lb	Age	State	K ⁴⁰ , dis/sec	K ⁴⁰ /lb	Cs/K	Date
1250	M	207	46	N. Mex.	456	2.19	0.282	9/14
1252	M	164	30	USAF	425	2.59	0.561	9/17
1253	M	139	30	USAF	447	3.21	0.531	9/17
1256	M	188	41	N. Mex.	561	2.98	0.666	9/19
1257	M	213	54	N. Mex.	479	2.25	0.816	9/19
1259	M	131	31	N. Mex.	303	2.30	0.523	9/20
1264	M	118	27	Canada	251	2.13	0.632	9/21
1269	M	152	42	Ill.	391	2.57	0.336	9/27
1272	M	190	26	N. Mex.	482	2.53	0.337	10/1
1275	M	154	30	N. Mex.	370	2.40	0.385	10/1
1280	M	178	34	N. Mex.	428	2.41	0.544	10/3
1281	M	175	44	N. Mex.	461	2.62	0.673	10/3
1282	M	167	49	Ill.	406	2.42	0.851	10/3
1283	M	181	34	N. Mex.	430	2.37	0.820	10/3
1286	F	050	08	N. Mex.	162	3.29	0.706	10/6
1287	M	110	13	N. Mex.	323	2.93	0.389	10/6
1288	M	065	11	N. Mex.	231	3.55	0.537	10/6
1289	M	148	42	USAF	431	2.91	0.465	10/8
1290	M	174	35	USAF	460	2.64	0.562	10/6
1298	M	172	49	N. Y.	419	2.44	0.478	10/12
1299	M	168	47	Tenn.	385	2.28	0.482	10/12
1300	M	178	42	Mich.	462	2.60	0.298	10/12
1301	M	177	34	Tenn.	437	2.47	0.449	10/12
1302	M	180	32	Md.	449	2.49	0.381	10/12
1303	M	155	32	Pa.	351	2.26	0.318	10/12
1304	M	190	38	Ohio	484	2.54	0.451	10/12
1305	M	155	40	N. Y.	402	2.59	0.756	10/12
1306	M	158	32	Colo.	398	2.52	0.473	10/12
1307	M	182	29	Md.	474	2.60	0.660	10/12
1308	M	155	30	Texas	490	3.16	0.355	10/12
1309	M	167	28	S. C.	438	2.61	0.460	10/12
1310	M	152	35	USAF	441	2.89	0.431	10/15
1311	M	174	36	USAF	440	2.53	0.492	10/15
1312	M	166	35	Tenn.	413	2.48	0.374	10/15
1316	M	144	30	Colo.	397	2.74	0.313	10/17
1317	M	127	30	Colo.	402	3.15	0.493	10/17
1325	M	187	30	Colo.	423	2.26	0.539	10/18
1326	M	132	34	Colo.	434	3.27	0.436	10/18
1327	M	173	36	N. Mex.	548	3.17	0.608	10/18
1328	M	203	42	Colo.	597	2.94	0.448	10/18
1331	M	270	24	Colo.	503	1.86	0.359	10/18
1333	M	147	27	Colo.	398	2.70	0.409	10/19
1334	M	218	34	Colo.	527	2.41	0.240	10/19
1335	M	270	30	Colo.	527	1.95	0.336	10/19
1352	F	144	30	Colo.	298	2.07	0.108	10/23
1355	F	126	40	N. Mex.	260	2.06	0.506	10/24
1356	F	158	30	N. Mex.	365	2.31	0.227	10/24
1357	F	138	30	N. Mex.	303	2.20	0.580	10/24
1358	F	126	35	N. Mex.	281	2.23	0.488	10/24
1359	M	173	30	N. Mex.	472	2.72	0.473	10/24
1363	F	118	18	N. Mex.	292	2.48	0.420	10/24
1364	M	176	25	USN	567	3.22	0.445	10/24
1366	M	166	40	N. Mex.	412	2.48	0.409	10/25
1367	M	123	36	N. Mex.	333	2.71	0.582	10/25
1368	M	157	25	N. Mex.	474	3.02	0.394	10/25

Table 48b (Continued)

Serial No.	Sex	Weight, lb	Age	State	K^{40} , dis/sec	K^{40} /lb	Cs/K	Date
1371	M	157	37	Okla.	465	2.96	0.480	10/26
1372	M	139	28	Colo.	390	2.80	0.606	10/26
1373	F	104	29	Calif.	218	2.10	0.357	10/26
1374	F	087	33	N. Mex.	219	2.52	0.534	10/26
1375	F	064	10	N. Mex.	187	2.92	0.257	10/26
1376	M	161	65	Calif.	405	2.52	0.101	10/26
1378	M	143	41	N. Mex.	395	2.76	0.893	10/30
1384	M	189	38	Calif.	456	2.41	0.365	11/5
1385	M	150	36	Calif.	425	2.83	0.420	11/5
1386	M	160	31	Calif.	476	2.97	0.404	11/5
1393	M	206	17	N. Mex.	559	2.71	0.345	11/13
1394	M	140	17	N. Mex.	433	3.09	0.392	11/13
1395	F	143	30	N. Mex.	310	2.16	0.670	11/14
1397	M	166	35	USAF	415	2.50	0.584	11/15
1399	M	165	34	USAF	422	2.55	0.489	11/15
1406	M	180	26	Tenn.	470	2.61	0.533	11/23
1407	M	157	31	Calif.	426	2.71	0.159	11/23
1422	M	206	17	N. Mex.	578	2.80	0.433	11/29
1429	M	133	29	D. C.	361	2.71	0.473	12/6
1431	M	188	41	N. Mex.	538	2.86	0.617	12/6
1438	M	203	38	N. Mex.	619	3.05	0.629	12/6

Table 48c—WHOLE-BODY Cs¹³⁷ CONTROLS, 1957
(Measured at the Los Alamos Scientific Laboratory)

Coding for 1957 Human Controls and General Whole Body Measurements

The human control group by individuals are listed. Table 48d lists the results on single measurements of general subjects tabulated by state or country. The columns are:

1. Serial number
2. Subject code and date of measurement
3. Date of measurement.
4. K⁴⁰ specific activity in gamma rays per second per pound
5. Cs/K gamma ratio

Serial No.	Subject code	Date of measurement	Potassium γ dis/sec/lb	γ ratio Cs/K	Serial No.	Subject code	Date of measurement	Potassium γ dis/sec/lb	γ ratio Cs/K
ECA					1400150932	6160	1/25	3.121	0.3941
1400143935	5310	1/3	3.714	0.3280	1400153032	6160	2/1	3.112	0.4303
1400144135	5310	1/9	2.791	0.4675	1400155232	6160	2/7	2.896	0.3628
1400147535	5310	1/17	2.985	0.3682	1400156832	6160	2/15	3.022	0.3033
1400150135	5310	1/24	2.988	0.5487	1400160432	6160	2/28	2.921	0.4608
1400156435	5310	2/14	2.544	0.5511	1400162232	6160	3/8	2.979	0.3585
1400158435	5310	2/19	2.622	0.4841	1400165632	6160	3/15	2.901	0.4066
1400159735	5310	2/26	2.827	0.4609	1400173132	6160	4/4	2.894	0.3184
1400163335	5310	3/11	2.718	0.4188	1400174232	6160	4/12	2.905	0.4178
1400165035	5310	3/14	2.754	0.4076	1400175932	6160	4/30	3.043	0.3546
1400170635	5310	3/21	2.791	0.3683	1400177232	6160	5/16	3.019	0.4337
1400173235	5310	4/4	2.818	0.4558	1400178332	6160	5/22	2.954	0.3484
1400174935	5310	4/26	2.822	0.4636	1400181432	6160	6/14	2.985	0.3320
1400176235	5310	5/14	2.881	0.4356	1400184032	6160	6/28	3.140	0.3461
1400182735	5310	6/21	2.870	0.6805	1400186732	6160	7/5	3.075	0.3638
1400186935	5310	7/5	2.881	0.6927	1400192132	6160	8/9	3.045	0.5103
1400188535	5310	7/17	2.829	0.6053	1400195932	6160	8/15	3.035	0.4564
1400191735	5310	8/7	2.651	0.5816	1400198732	6160	8/21	3.087	0.4046
1400190835	5310	7/30	2.865	0.6236	1400191132	6160	8/1	3.185	0.4715
1400199035	5310	8/30	2.683	0.5990	1400198932	6160	8/30	2.992	0.5592
1400205537	5310	10/8	2.948	0.7359	1400200232	6160	9/5	3.053	0.4651
1400210537	5310	10/24	2.992	0.7655	1400208833	6160	10/18	3.020	0.4984
1400207937	5310	10/17	2.800	0.7510	1400210333	6160	10/24	2.915	0.5598
1400216037	5310	11/18	2.753	0.7069	1400211333	6160	11/1	2.864	0.4512
1400218037	5310	12/2	2.887	0.7133	1400214833	6160	11/15	2.880	0.4435
1400222437	5310	12/20	2.942	0.7169	1400216133	6160	11/18	2.942	0.4518
1400225737	5310	12/30	2.739	0.7713	1400218933	6160	12/4	2.979	0.5353
WDM					1400219433	6160	12/9	2.968	0.5056
1400152632	6440	1/31	3.091	0.4518	MES				
1400155032	6440	2/6	3.162	0.2775	1400212740	4520	11/7	2.462	0.5745
1400157232	6440	2/15	2.972	0.3953	1400208140	4520	10/17	2.277	0.4845
1400158232	6440	2/19	2.937	0.3605	1400210140	4520	10/24	2.149	0.7635
1400160032	6440	2/27	2.979	0.2772	1400219540	4520	12/9	2.273	0.7378
1400161732	6440	3/6	2.981	0.2885	JBS				
1400165232	6440	3/14	2.936	0.4196	1400144432	1220	1/9	3.238	0.3066
1400170032	6440	3/20	3.044	0.2145	1400146332	1220	1/14	3.143	0.3370
1400172332	6440	3/27	2.951	0.3165	1400149132	1220	1/21	3.160	0.4294
1400172632	6440	4/3	3.001	0.3318	1400151732	1220	1/28	3.243	0.3699
1400175332	6440	4/26	3.050	0.3160	1400157532	1220	2/18	3.045	0.6076
1400177332	6440	5/16	3.055	0.3206	1400159132	1220	2/25	3.260	0.3390
1400178132	6440	5/22	2.897	0.2764	1400161332	1220	3/4	2.957	0.4106
1400181032	6440	6/14	2.824	0.2794	1400163532	1220	3/11	3.009	0.2447
1400183332	6440	6/26	2.984	0.5870	1400172032	1220	3/26	3.073	0.2986
1400184532	6440	7/2	3.258	0.2277	1400173632	1220	4/4	3.019	0.2472
1400187632	6440	7/9	2.856	0.6295	1400174732	1220	4/15	3.056	0.2380
1400191932	6440	8/8	3.052	0.2491	1400175532	1220	4/26	3.340	0.2318
1400190932	6440	8/1	3.035	0.3591	1400176632	1220	5/15	3.310	0.2449
1400198232	6440	8/26	2.926	0.4751	1400177732	1220	5/20	3.118	0.2809
1400201133	6440	9/6	3.102	0.7290	1400178532	1220	5/31	3.397	0.4979
1400215033	6440	11/15	2.875	0.5586	1400178632	1220	5/31	3.149	0.3937
1400220433	6440	12/10	3.061	0.5542	1400180832	1220	6/14	3.013	0.3974
1400222533	6440	12/20	2.899	0.5704	1400183232	1220	6/26	3.157	0.3745
1400225833	6440	12/30	2.914	0.5799	1400198032	1220	8/26	3.088	0.4965
LJR					1400200334	1220	9/5	3.091	0.5548
1400146444	3190	1/14	2.964	0.3475	1400206134	1220	10/8	3.215	0.4934
1400149544	3190	1/23	3.272	0.9031	1400208234	1220	10/17	3.153	0.4631
1400152844	3190	1/31	2.897	0.3849	1400210034	1220	10/24	2.992	0.5826
1400155344	3190	2/7	2.707	0.3916	1400213234	1220	11/7	3.137	0.4477
1400157144	3190	2/15	2.901	0.3067	1400215234	1220	11/15	2.999	0.4398
WJW					1400217034	1220	11/25	3.083	0.5331
1400145432	6160	1/10	3.144	0.3785	1400218734	1220	12/4	3.210	0.4737
1400147732	6160	1/18	3.095	0.4403	1400220534	1220	12/11	3.050	0.5637
					1400222734	1220	12/20	3.143	0.4373
					1400224434	1220	12/26	3.079	0.3981

Table 48c (Continued)

Serial No.	Subject code	Date of measurement	Potassium γ dis./sec/lb	γ ratio Cs/K	Serial No.	Subject code	Date of measurement	Potassium γ dis./sec/lb	γ ratio Cs/K
		BCE							
1400147333	2350	1/16	2.415	0.5528	1400184431	1460	7/2	2.421	0.7236
1400151033	2350	1/25	2.528	0.6979	1400187831	1460	7/9	2.277	0.8443
1400153233	2350	2/1	2.549	0.4479	1400189631	1460	7/22	2.196	0.4995
1400155133	2350	2/7	2.297	0.6557	1400192231	1460	8/9	2.294	0.4912
1400157733	2350	2/18	2.407	0.5442	1400198831	1460	8/30	2.359	0.4390
1400158733	2350	2/20	2.385	0.6498	1400214932	1460	11/15	2.257	0.5828
1400160733	2350	3/1	2.547	0.5823	1400219732	1460	12/9	2.263	0.5216
1400162033	2350	3/7	2.555	0.5127	1400224132	1460	12/26	2.263	0.6505
1400165433	2350	3/14	2.474	0.5425			CFH		
1400170533	2350	3/21	2.568	0.4710	1400145843	3680	1/11	2.495	0.4023
1400172233	2350	3/27	2.485	0.7421	1400151643	3680	1/28	2.383	0.3024
1400173033	2350	4/3	2.546	0.6080	1400153543	3680	2/4	2.498	0.2324
1400174333	2350	4/12	2.471	0.6128	1400155743	3680	2/8	2.375	0.2914
1400177133	2350	5/16	2.420	0.6696	1400157443	3680	2/18	2.321	0.2026
1400178233	2350	5/22	2.456	0.5394	1400146543	3880	1/14	2.393	0.3528
1400145933	2350	1/11	2.417	0.5033	1400148943	3880	1/21	2.279	0.2564
1400182133	2350	6/17	2.658	0.6114			RLS		
1400184333	2350	7/2	2.558	0.9586	1400144031	9320	1/3	2.560	0.2953
1400187733	2350	7/9	2.530	0.7784	1400144231	9320	1/9	2.567	0.4134
1400189233	2350	7/22	3.186	0.8348	1400146631	9320	1/14	2.442	0.4483
1400196033	2350	8/15	2.547	0.8073	1400148831	9320	1/21	2.611	0.3724
1400196933	2350	8/21	2.498	0.5782	1400153931	9320	2/4	2.666	0.3836
1400190733	2350	7/30	2.496	0.6740	1400156631	9320	2/14	2.533	0.3180
1400200934	2350	9/6	2.740	0.9421	1400157831	9320	2/18	2.504	0.3640
1400206534	2350	10/9	2.453	0.7309	1400169631	9320	3/19	2.614	0.3790
1400207734	2350	10/16	2.417	0.7317	1400172131	9320	3/26	2.541	0.3335
1400209834	2350	10/24	2.311	0.7820	1400173731	9320	4/4	2.502	0.3129
1400214634	2350	11/15	2.376	0.6297	1400176331	9320	5/14	2.497	0.3388
1400219834	2350	12/9	2.512	0.7198	1400178431	9320	5/22	2.549	0.3828
1400224534	2350	12/26	2.419	0.5918	1400183831	9320	6/28	2.556	0.5819
		IVB			1400188431	9320	7/17	2.607	0.4695
1400146134	9420	1/11	2.314	0.3900	1400189031	9320	7/22	2.646	0.4487
1400146834	9420	1/14	2.112	0.3178	1400196531	9320	8/21	2.545	0.4776
1400148734	9420	1/21	2.241	0.4265	1400197931	9320	8/26	2.538	0.5132
1400152234	9420	1/30	2.428	0.6565	1400200031	9320	9/3	2.623	0.5032
1400153734	9420	2/4	2.286	0.3595	1400201332	9320	9/6	2.740	0.7613
1400157934	9420	2/18	2.090	0.3102			PSH		
1400159034	9420	2/25	2.054	0.4109	1400151134	7280	1/25	2.641	0.4533
1400161134	9420	3/4	2.008	0.5077	1400154034	7280	2/4	2.457	0.3048
1400163134	9420	3/11	1.912	0.5064	1400158634	7280	2/20	2.343	0.5316
1400169234	9420	3/19	2.067	0.6360	1400160934	7280	3/1	2.581	0.3853
1400171334	9420	3/25	2.129	0.4781	1400162534	7280	3/8	2.408	0.3899
1400176534	9420	5/14	1.991	0.4839	1400184634	7280	7/2	2.667	0.4169
1400181134	9420	6/14	2.323	0.5740	1400207435	7280	10/16	2.519	0.5773
1400183534	9420	6/26	2.766	0.7563	1400216335	7280	11/18	2.642	0.5945
1400195634	9420	8/15	2.090	0.5560			WHL		
1400190634	9420	7/30	2.035	0.4658	1400146245	6830	1/11	2.985	0.4997
1400198534	9420	8/27	2.115	0.4313	1400147145	6830	1/16	3.012	0.3368
1400200134	9420	9/5	2.393	0.6417	1400151845	6830	1/30	3.520	0.6451
1400208035	9420	10/17	2.076	0.5445	1400157345	6830	2/15	2.839	0.6111
1400211435	9420	11/1	2.082	0.5308	1400159445	6830	2/25	2.759	0.6909
1400206435	9420	10/8	2.317	0.6347	1400161645	6830	3/5	2.937	0.4373
1400213335	9420	11/7	2.112	0.4111	1400163645	6830	3/12	2.835	0.4894
1400214435	9420	11/15	1.976	0.5006	1400170845	6830	3/22	2.949	0.3635
1400216735	9420	11/25	2.208	0.6840	1400175645	6380	4/26	2.961	0.5630
1400220035	9420	12/10	2.209	0.5566	1400177445	6830	5/17	2.971	0.4430
1400224235	9420	12/26	2.085	0.5658	1400181845	6830	6/15	3.013	0.5310
		JMW			1400191845	6830	8/7	2.909	0.6676
1400149831	1460	1/24	2.409	0.2091	1400198645	6830	8/30	2.950	0.5759
1400153631	1460	2/4	2.424	0.4428	1400200546	6830	9/5	3.096	0.6214
1400156531	1460	2/14	2.310	0.3553	1400206646	6830	10/9	3.138	0.6756
1400159231	1460	2/25	2.305	0.5141	1400210646	6830	10/24	2.935	0.6022
1400160831	1460	3/1	2.373	0.4613			LJC		
1400162331	1460	3/8	2.253	0.4916	1400145536	3130	1/10	3.041	0.2985
1400165731	1460	3/15	2.283	0.4975	1400151236	3130	1/25	2.951	0.5025
1400171731	1460	3/26	2.233	0.4262	1400153136	3130	2/1	2.868	0.4050
1400175731	1460	4/30	2.380	0.5170	1400156736	3130	2/14	2.766	0.3779
1400176931	1460	5/16	2.323	0.5197	1400158936	3130	2/20	2.926	0.3148
1400178731	1460	5/31	2.664	0.6431	1400162436	3130	3/8	2.748	0.3718
1400181231	1460	6/14	2.391	0.4971					
1400182931	1460	6/21	2.460	0.4400					

Table 48c (Continued)

Serial No.	Subject code	Date of measurement	Potassium γ dis/sec/lb	γ ratio Cs/K	Serial No.	Subject code	Date of measurement	Potassium γ dis/sec/lb	γ ratio Cs/K
1400165936	3130	3/15	2.863	0.4231			PCS		
1400171936	3130	3/26	2.991	0.2756	1400145030	7320	1/10	2.311	0.3207
1400173436	3130	4/4	2.862	0.5019	1400146930	7320	1/15	2.215	0.2356
1400174436	3130	4/12	2.864	0.4659	1400152030	7320	1/30	2.515	0.5596
1400177036	3130	5/16	2.868	0.3697	1400175230	7320	4/26	2.267	0.6166
1400181536	3130	6/14	3.003	0.3731	1400177930	7320	5/22	2.118	0.4889
1400184136	3130	6/28	2.981	0.5474	1400187530	7320	7/9	2.096	0.5866
1400186836	3130	7/5	3.151	0.4712	1400188930	7320	7/22	2.253	0.4089
1400189536	3130	7/22	2.999	0.5390	1400200432	7320	9/5	2.100	0.5125
1400192036	3130	8/9	2.933	0.5261	1400205732	7320	10/8	2.418	0.4832
1400200637	3130	9/5	2.880	0.5087	1400209932	7320	10/24	2.076	0.6246
1400206037	3130	10/8	2.983	0.5958	1400218132	7320	12/2	2.238	0.5390
1400210737	3130	10/25	3.078	0.4210	1400219232	7320	12/9	2.116	0.6865
1400222137	3130	12/19	2.851	0.6405			RFA		
		OSJ			1400145227	9610	1/10	2.920	0.2678
1400144541	6210	1/9	2.616	0.3618	1400146727	9610	1/14	2.734	0.2790
1400148141	6210	1/18	2.666	0.3134	1400149027	9610	1/21	3.055	0.2703
1400152541	6210	1/31	2.628	0.2596	1400151527	9610	1/28	2.963	0.2652
1400154341	6210	2/5	2.596	0.3632	1400153827	9610	2/4	3.108	0.1780
1400160341	6210	2/28	2.410	0.4803	1400155627	9610	2/8	2.881	0.2479
1400169141	6210	3/19	2.413	0.3733	1400158027	9610	2/18	2.953	0.2970
1400173541	6210	4/4	2.421	0.3118	1400159327	9610	2/25	2.843	0.2701
1400175841	6210	4/30	2.606	0.3091	1400161227	9610	3/4	2.770	0.4308
1400184741	6210	7/2	2.943	0.7187	1400163427	9610	3/11	2.890	0.1827
1400189141	6210	7/22	2.692	0.4449	1400169527	9610	3/19	2.785	0.3058
1400191641	6210	8/7	2.433	0.3713	1400171827	9610	3/26	2.943	0.2744
1400198741	6210	8/30	2.624	0.4268	1400172927	9610	4/3	2.817	0.2848
1400199941	6210	9/3	2.709	0.4026	1400174627	9610	4/15	2.844	0.3466
1400207343	6210	10/16	2.546	0.3994	1400175027	9610	4/26	3.080	0.1715
1400219943	6210	12/9	2.521	0.4007	1400176427	9610	5/14	2.938	0.2819
1400216843	6210	11/25	2.531	0.4758	1400178027	9610	5/22	3.094	0.1758
		DCW			1400180927	9610	6/14	3.053	0.3714
1400150832	4360	1/25	2.615	0.4998	1400187427	9610	7/9	3.223	0.3208
1400152932	4360	2/1	2.436	0.5690	1400199827	9610	9/3	3.049	0.4640
1400156932	4360	2/15	2.518	0.5966	1400205827	9610	10/8	3.065	0.4212
1400158532	4360	2/20	2.403	0.6185	1400207827	9610	10/17	2.951	0.3247
1400160532	4360	3/1	2.530	0.4943	1400210227	9610	10/24	2.907	0.4713
1400169332	4360	3/19	2.476	0.4817	1400214327	9610	11/15	3.034	0.3837
1400173332	4360	4/4	2.375	0.3951	1400216627	9610	11/25	2.977	0.4511
1400175432	4360	4/26	2.463	0.4806	1400218327	9610	12/2	2.988	0.4492
1400191032	4360	8/1	2.553	0.4793	1400220327	9610	12/10	3.001	0.4981
1400189332	4360	7/22	2.535	0.5095	1400222627	9610	12/20	2.976	0.4115
1400200732	4360	9/5	2.560	0.5481			FPE		
1400208733	4360	10/18	2.355	0.5330	1400205926	6750	10/8	3.041	0.6452
1400211533	4360	11/1	2.443	0.4791	1400207226	6750	10/16	2.750	0.6039
1400212433	4360	11/7	2.463	0.4732	1400210826	6750	10/25	2.747	0.5900
1400216233	4360	11/18	2.510	0.5249	1400214726	6750	11/15	2.670	0.5616
1400218833	4360	12/4	2.564	0.5777	1400215826	6750	11/18	2.712	0.5659
1400224333	4360	12/26	2.498	0.7833	1400218426	6750	12/2	2.747	0.7188
		SBH					WHS		
1400145122	2280	1/10	2.422	0.3831	1400144930	6820	1/9	2.541	0.1431
1400151422	2280	1/25	2.416	0.2628	1400147230	6820	1/16	2.533	0.5392
1400153322	2280	2/1	2.414	0.3187	1400149630	6820	1/23	2.695	0.2506
1400155522	2280	2/8	2.469	0.2894	1400151930	6820	1/30	2.951	0.4622
1400157022	2280	2/15	2.493	0.3909	1400155430	6820	2/8	2.660	0.2447
1400158822	2280	2/20	2.480	0.2816	1400158330	6820	2/19	2.541	0.4262
1400160622	2280	3/1	2.577	0.3254	1400159530	6820	2/26	2.486	0.4509
1400162122	2280	3/7	2.356	0.3432	1400163230	6820	3/11	2.412	0.3252
1400165822	2280	3/15	2.411	0.4016	1400163930	6820	3/13	2.418	0.3999
1400170922	2280	3/22	2.281	0.3450	1400170130	6820	3/20	2.511	0.3155
1400174522	2280	4/12	2.396	0.1691	1400172430	6820	4/3	5.929	0.6034
1400176722	2280	5/15	2.536	0.2185	1400176030	6820	4/30	2.579	0.3032
1400182222	2280	6/17	2.632	0.5031	1400182030	6820	6/17	2.639	0.3903
1400183922	2280	6/28	2.829	0.5322	1400183130	6820	6/26	2.588	0.5243
1400189422	2280	7/22	2.617	0.5066	1400191430	6820	8/7	2.705	0.4694
1400196622	2280	8/21	2.581	0.3803	1400195830	6820	8/15	2.407	0.4292
1400209023	2280	10/18	2.379	0.5784	1400190530	6820	7/30	2.618	0.5529
1400210423	2280	10/24	2.539	0.5789	1400198330	6820	8/26	2.415	0.4337
1400220223	2280	12/10	2.422	0.4718					

Table 48c (Continued)

Serial No.	Subject code	Date of measurement	Potassium γ dis/sec/lb	γ ratio Cs/K	Serial No.	Subject code	Date of measurement	Potassium γ dis/sec/lb	γ ratio Cs/K
1400200831	6820	9/5	2.553	0.4110	1400163719	2230	3/12	2.018	0.2960
1400206231	6820	10/8	2.480	0.4493	1400169419	2230	3/19	1.965	0.4168
1400207131	6820	10/16	2.509	0.4382	1400171619	2230	3/26	2.138	0.2946
1400216931	6820	11/25	2.568	0.3981	1400172519	2230	4/3	2.145	0.1980
1400219631	6820	12/9	2.357	0.5718	1400175119	2230	4/26	2.072	0.3418
1400222031	6820	12/19	2.440	0.5882	1400176819	2230	5/15	1.982	0.2851
					1400177819	2230	5/20	1.960	0.2680
		MAVD			1400181319	2230	6/14	2.268	0.3479
1400210938	4154	10/25	2.930	1.1573	1400183419	2230	6/26	2.649	1.0971
1400207638	4154	10/16	2.719	1.4024	1400184219	2230	7/2	2.304	0.5495
1400214238	4154	11/15	2.776	1.1053	1400189719	2230	7/22	1.984	0.4733
1400215938	4154	11/18	2.863	1.1817	1400190419	2230	7/30	1.955	0.3804
1400218238	4154	12/2	3.108	1.0299	1400191319	2230	8/7	1.877	0.0523
1400221938	4154	12/19	2.907	1.0995	1400195719	2230	8/15	2.221	0.3607
		JER			1400196819	2230	8/21	2.132	0.2744
1400144329	1590	1/9	2.906	0.3054	1400198119	2230	8/26	2.034	0.5222
1400147429	1590	1/16	2.719	0.2805	1400201020	2230	9/6	3.174	1.0742
		BST			1400201220	2230	9/6	2.620	0.6074
1400147019	2230	1/15	2.142	0.3879	1400205620	2230	10/8	2.070	0.5975
1400149219	2230	1/22	2.196	0.2822	1400207520	2230	10/16	2.008	0.2560
1400152119	2230	1/30	2.394	0.2712	1400209720	2230	10/24	1.923	0.5106
1400154219	2230	2/5	2.241	0.3032	1400211220	2230	10/31	2.114	0.3628
1400156319	2230	2/11	2.332	0.1903	1400212220	2230	11/6	2.123	0.2930
1400157619	2230	2/18	2.174	0.3043	1400214520	2230	11/15	2.036	0.3293
1400160219	2230	2/28	2.195	0.2570	1400215720	2230	11/18	2.194	0.2896
1400181519	2230	3/5	1.958	0.3779	1400218520	2230	12/2	2.118	0.4592
					1400220120	2230	12/10	2.044	0.2957
					1400222320	2230	12/20	1.912	0.4823
					1400146019	2230	1/11	2.220	0.1972

Table 48d—WHOLE-BODY Cs¹³⁷ DETERMINATIONS, 1957
(Measured at the Los Alamos Scientific Laboratory)

Serial No.	Subject code	Date of measurement	Potassium γ dis/sec/lb	γ ratio Cs/K	Serial No.	Subject code	Date of measurement	Potassium γ dis/sec/lb	γ ratio Cs/K
		Alabama			1000203831	3636	9/23	2.436	0.4776
1000180042	1310	6/10	2.915	0.5237	1000203932	3636	9/23	3.017	0.5993
		Arizona			1000203634	3636	9/23	2.973	0.4062
1000192740	1999	8/13	2.799	0.3624	1000203434	3636	9/23	2.769	0.5497
		California			1000202934	3636	9/23	2.710	0.5773
1000147949	3130	1/18	2.032	0.3795	1000201834	3636	9/23	2.604	0.5994
1000148065	3130	1/18	1.835	0.3765	1000203335	3636	9/23	2.457	0.3478
1000152432	3130	1/30	2.988	0.4632	1000202339	3636	9/23	2.423	0.5255
1000152334	3130	1/30	3.541	0.4739	1000203140	3636	9/23	2.135	0.5706
1000162764	3130	3/8	2.786	0.2088	1000202542	3636	9/23	2.497	0.4261
1100162660	3130	3/8	1.489	0.2226	1000203045	3636	9/23	2.424	0.3883
1000174130	3130	4/12	2.745	0.4146	1000202847	3636	9/23	2.384	0.4258
1000174034	3130	4/12	2.902	0.4651	1000205429	3636	1/4	3.234	0.9110
1000180229	3130	6/11	2.982	0.4843	1000205139	3636	10/4	2.375	0.7605
1000184927	3130	7/2	3.207	0.3715	1000204943	3636	10/4	3.089	0.8133
1000188236	3130	7/17	3.123	0.5074	1100204439	3636	10/4	2.294	0.9147
1000188337	3130	7/17	2.979	0.4524	1100204642	3636	10/4	2.440	0.6481
1000193632	3130	8/13	2.568	0.3956	1100204842	3636	10/4	2.476	0.7611
1000192935	3130	8/13	2.326	0.4228	1100204744	3636	10/4	2.393	0.8160
1000194835	3130	8/13	2.703	0.4786	1000217210	3636	11/27	2.038	0.8270
1000194936	3130	8/13	2.631	0.4719	1000217141	3636	11/27	2.477	0.6625
1000195536	3130	8/14	2.507	0.3771	1100217330	3636	11/27	2.420	0.9547
1000208959	3130	10/18	2.509	0.5002			Connecticut		
1000216526	3130	11/19	2.946	0.5396	1000160128	3655	2/27	2.580	0.6609
		Colorado			1100211643	3655	11/1	2.235	0.6233
1000154947	3636	2/6	2.578	0.6440			District of Columbia		
1100181678	3636	6/15	1.857	0.3051	1000159942	4300	2/26	2.719	0.5257
1000199323	3636	9/1	2.866	0.4009	1000164226	4300	3/14	2.118	0.3777
1100199123	3636	9/1	2.463	0.7423	1000170239	4300	3/21	2.458	0.4377
1000199637	3636	9/3	2.914	0.5428	1000170345	4300	3/21	2.422	0.4430
1000203730	3636	9/23	3.064	0.5643	1000171107	4300	3/24	2.741	0.4216
					1100171026	4300	3/24	2.549	0.6070

Table 48d (Continued)

Serial No.	Subject code	Date of measurement	Potassium γ dis/sec/lb	γ ratio Cs/K	Serial No.	Subject code	Date of measurement	Potassium γ dis/sec/lb	γ ratio Cs/K
1000177541	4300	5/17	2.739	0.4010					
1000182529	4300	6/20	2.385	0.5635					
1000183746	4300	6/28	2.713	0.5607					
1000211738	4655	11/1	2.619	0.5376					
		Georgia							
1000194141	7100	8/13	2.639	0.4624					
		Illinois							
1000159632	9330	2/26	2.394	0.5516					
1100159929	9330	2/27	2.180	0.4727					
1000176131	9330	5/10	2.484	0.3481					
1000184825	9330	7/2	3.236	0.5562					
1000185821	9330	7/3	2.733	0.4976					
1000188167	9330	7/16	1.869	0.8733					
1100188061	9330	7/16	1.816	0.9876					
1000199422	9330	9/3	3.303	0.5955					
1000204352	9330	9/30	3.042	0.6382					
		Indiana							
1000186022	9540	7/3	2.837	0.7916					
		Iowa							
1000151367	9661	1/25	2.487	0.4287					
1000178830	9661	6/3	3.031	0.3318					
1000196136	9661	8/16	2.580	0.4214					
1100196406	9661	8/16	3.768	0.3992					
1100196230	9661	8/16	2.212	0.5831					
1100196363	9661	8/16	1.881	0.5486					
		Kirtland AFB							
1000163026	2162	3/11	2.731	0.2256					
1000162927	2162	3/11	2.813	0.3509					
1000179326	2162	6/5	2.987	0.5531					
1000179627	2162	6/5	2.773	1.3953					
1000179129	2162	6/5	2.424	0.6463					
1000179532	2162	6/5	2.390	0.6267					
1000179433	2162	6/5	3.163	0.5241					
1000179233	2162	6/5	2.780	0.5829					
		Kansas							
1000144611	2150	1/9	2.756	0.7552					
1000144735	2150	1/9	2.852	0.5059					
1000164132	2150	3/14	2.518	0.4906					
1000170437	2150	3/21	2.333	0.2586					
1000179737	2150	6/5	2.942	0.5660					
1000195429	2150	8/13	2.880	0.3918					
		Lovelace Clinic							
1000162732	3655	1/31	2.880	0.3092					
1000154136	3655	2/5	2.585	0.3463					
1000208329	3655	10/18	2.515	0.5994					
1000208429	3655	10/18	2.729	0.6865					
1000208530	3655	10/18	2.767	0.5315					
1000208633	3655	10/18	2.571	0.4851					
1000213127	3655	11/7	3.122	0.5744					
1000214132	3655	11/14	2.917	0.8286					
1000213832	3655	11/14	3.044	0.8791					
1000213936	3655	11/14	2.823	0.8581					
1000214039	3655	11/14	2.732	0.4948					
		Maine							
1000169817	4500	3/20	2.710	0.5820					
1000169954	4500	3/20	2.474	0.5126					
1000194355	4500	8/13	2.524	0.5604					
		Maryland							
1000182647	4400	6/20	2.273	0.7960					
1000197431	4400	8/26	2.737	0.6677					
1000197731	6428	8/26	2.711	0.6114					
		Massachusetts							
1000185222	4122	7/2	3.093	0.6224					
1000185323	4122	7/2	3.526	0.5448					
1000185423	4122	7/2	2.912	0.8686					
1000185924	4122	7/3	3.084	0.5415					
1100213535	4122	11/8	2.308	0.7591					
		Michigan							
1000150070	4938	1/24	2.439	0.7143					
1100149962	4938	1/24	1.755	0.6072					
1100161924	4938	3/7	2.440	0.1781					
		Minnesota							
1000193534	4955	8/13	2.403	0.5056					
1000194741	4955	8/13	2.557	0.4206					
		Mississippi							
1100170733	4600	3/22	1.979	0.3633					
1000203540	4600	9/23	2.526	0.3515					
1000202244	4600	9/23	2.202	0.3356					
		Nebraska							
1000186224	5520	7/3	2.096	0.1422					
1000194233	5520	8/13	2.720	0.4656					
		New Jersey							
1000180724	5100	6/14	2.880	0.6123					
1000192824	5100	8/13	3.154	0.6825					
1000194027	5100	8/13	3.271	0.4876					
1000195030	5100	8/13	3.362	0.3443					
1000199728	5100	9/3	2.554	0.6237					
		New Mexico							
1000145723	5400	1/11	2.987	0.4935					
1000145624	5400	1/11	3.022	0.4480					
1000148658	5400	1/21	2.692	0.2786					
1100149731	5400	1/23	2.469	0.3054					
1000150234	5400	1/24	2.521	0.4728					
1000150538	5400	1/24	3.162	0.3696					
1000150439	5400	1/24	2.795	0.4243					
1000150640	5400	1/24	3.555	0.5002					
1000150341	5400	1/24	2.274	0.3865					
1000150743	5400	1/24	2.815	0.2373					
1000153435	5400	2/1	2.600	0.2755					
1000154824	5400	2/5	2.677	0.2576					
1000156014	5400	2/11	2.879	0.7055					
1000156215	5400	2/11	2.757	0.7524					
1000156116	5400	2/11	3.063	0.0070					
1000155816	5400	2/11	2.979	0.4431					
1000155916	5400	2/11	3.462	0.6746					
1000161051	5400	3/1	2.471	0.4548					
1000162855	5400	3/8	2.525	0.4052					
1100163831	4400	3/13	2.342	0.6120					
1000164822	5400	3/14	2.974	0.4313					
1000164926	5400	3/14	2.754	0.3664					
1000164639	5400	3/14	2.245	0.2443					
1100165338	5400	3/14	1.867	0.3324					
1000165513	5400	3/15	2.719	0.4386					
1000167712	5400	3/16	3.161	0.3440					
1000168913	5400	3/16	2.965	0.5640					
1000167413	5400	3/16	3.293	0.8226					
1000168815	5400	3/16	2.913	0.3178					
1000166616	5400	3/16	3.432	0.3337					
1000166416	5400	3/16	3.271	0.3498					
1000168116	5400	3/16	3.574	0.3604					
1000167316	5400	3/16	3.422	0.5766					
1000166517	5400	3/16	3.456	0.2761					
1000166317	5400	3/16	3.162	0.3409					
1000166817	5400	3/16	3.754	0.7361					
1000166018	5400	3/16	3.636	0.1529					

Table 48d (Continued)

Serial No.	Subject code	Date of measurement	Potassium γ dis/sec/lb	γ ratio Ca/K	Serial No.	Subject code	Date of measurement	Potassium γ dis/sec/lb	γ ratio Ca/K
1000168218	5400	3/16	3.129	0.2852	1000215108	5400	11/15	2.686	0.5046
1000168019	5400	3/16	3.238	0.3450	1100215500	5400	11/15	2.450	0.0726
1000168640	5400	3/16	2.255	0.2243	1100215603	5400	11/15	2.137	0.0905
1100168312	5400	3/16	3.108	0.1971	1100215409	5400	11/15	2.318	0.6041
1100168412	5400	3/16	3.203	0.3266	1000216441	5400	11/18	2.377	0.4860
1100166713	5400	3/16	3.024	0.2843	1000217508	5400	11/27	2.787	0.4718
1100168513	5400	3/16	3.059	0.5417	1000217427	5400	11/27	2.639	0.4697
1100167815	5400	3/16	2.732	0.5779	1100217707	5400	11/27	2.557	0.5358
1100166915	5400	3/16	2.533	0.6018	1100217627	5400	11/27	2.393	0.4421
1100166116	5400	3/16	2.473	0.2923	1000218627	5400	12/3	2.763	0.5431
1100167116	5400	3/16	2.397	0.5033	1000219121	5400	12/6	3.001	0.8998
1100167216	5400	3/16	2.567	0.7207	1000219022	5400	12/6	3.314	0.9787
1100167917	5400	3/16	2.829	0.4322	1000220962	5400	12/16	2.352	0.5889
1100167017	5400	3/16	2.294	0.4363	1100225305	5400	12/27	2.307	751
1100167517	5400	3/16	2.695	0.4904	1000225206	5400	12/27	2.235	0.7352
1100166217	5400	3/16	2.727	0.5028	1100224806	5400	12/27	2.520	0.6429
1100167617	5400	3/16	2.656	0.5837	1100224906	5400	12/27	2.356	0.7528
1000169037	5400	3/18	2.671	0.3998	1100224707	5410	12/27	2.511	0.3446
1000169732	5400	3/20	2.854	0.3746	1000225409	5400	12/27	2.815	0.7131
1000171231	5400	3/25	3.264	0.3388	1000225611	5400	12/27	2.844	0.4881
1000172735	5400	4/3	6.454	0.0134	1000225513	5400	12/27	2.726	0.4906
1000172842	5400	4/3	1.900	0.0391	1000225133	5400	12/27	3.076	0.4791
1000173830	5400	4/10	2.568	0.2809					
1000173933	5400	4/10	2.782	0.2119			New York		
1000174804	5400	4/21	6.371	0.2119	1000147652	5800	1/17	2.315	0.4918
1000177641	5400	5/17	2.700	0.5473	1000148430	5800	1/21	3.061	0.3380
1000179932	5400	6/5	3.146	0.4541	1000148547	5800	1/21	2.396	0.4027
1000179842	5400	6/5	3.350	0.7289	1000161847	5800	3/7	2.670	0.4096
1000180157	5400	6/10	2.536	0.8061	1000182823	5800	6/21	2.650	0.5707
1000180332	5400	6/11	2.623	0.3770	1100187130	5800	7/6	2.584	0.6211
1000180531	5400	6/13	3.193	0.3397	1000190034	5800	7/29	2.642	0.6498
1100180424	5400	6/13	2.063	0.6292	1000191285	5800	8/1	2.305	0.5644
1000180619	5400	6/14	3.299	0.4669	1100192317	5800	8/11	3.009	0.4851
1000181741	5400	6/15	3.251	0.4404	1100192457	5800	8/11	2.123	0.5825
1100181934	7320	6/17	2.092	0.4618	1000193130	5800	8/13	2.396	0.6625
1100183034	5400	6/21	1.979	0.7358	1000193334	5800	8/13	2.575	0.4516
1000186524	5400	7/3	3.037	0.3229	1000201956	5800	9/23	2.677	0.5429
1000187928	5400	7/12	2.819	0.4236	1100204533	5800	10/4	3.826	0.9493
1000188705	5400	7/21	3.423	1.0607					
1000188810	5400	7/21	2.469	0.6782			North Carolina		
1000189808	5400	7/27	3.124	0.7987	1000188659	5300	7/19	2.879	0.5524
1000192658	5400	8/11	2.919	0.4583					
1100192557	5400	8/11	1.810	0.6486			North Dakota		
1000193929	5400	8/13	2.563	0.6955	1000211155	5412	10/29	2.798	0.4872
1000194649	5400	8/13	2.792	0.2004					
1000194458	5400	8/13	3.032	0.1791			Ohio		
1000199226	5400	9/1	2.636	0.5693	1000149442	6896	1/23	2.791	0.4312
1000202634	5400	9/23	3.149	0.3939	1100149334	6896	1/23	2.466	0.7261
1000203234	5400	9/23	2.743	1.1341	1000164328	6896	3/14	2.484	0.3723
1000202440	5400	9/23	2.673	0.5285	1000185522	6896	7/2	3.261	0.6269
1000204053	5400	9/23	2.718	0.4831	1000186125	6896	7/3	2.391	0.7532
1000202155	5400	9/23	2.034	0.4933	1000193028	6896	8/13	3.029	0.5111
1000204157	5400	9/23	2.567	0.5589	1000195330	6896	8/13	2.706	0.6038
1000205227	5400	10/4	2.624	0.7738	1000195230	6896	8/13	3.093	0.7555
1000205049	5400	10/4	2.250	0.7131	1000197052	6896	8/26	2.449	0.6799
1100206340	5400	10/8	2.379	0.6206	1000206734	6896	10/15	3.137	0.4737
1000206946	5400	10/15	2.596	0.4371	1000207074	6896	10/15	2.610	0.4850
1100209421	5400	10/22	1.781	0.4807	1100206843	6896	10/15	2.201	0.3831
1100209325	5400	10/22	2.273	0.6902	1000223705	6896	12/24	2.726	0.6245
1100209535	5400	10/22	2.387	0.5949	1000223808	6896	12/24	2.469	0.4241
1100209147	5400	10/22	1.951	0.4897	1000223943	6896	12/24	2.976	0.4639
1100211010	5400	10/29	2.531	0.4555	1100223635	6896	12/24	2.414	0.6135
1100212119	5470	11/6	2.501	0.3140					
1000212307	5400	11/6	3.241	0.6927			Oklahoma		
1000212906	5400	11/7	2.906	0.3455	1000185123	6231	7/2	2.214	0.4033
1000213007	5400	11/7	3.292	0.3317	1000195146	6231	8/13	2.968	0.3740
1000212808	5400	11/7	3.347	0.5817					
1000212614	5400	11/7	3.040	0.4779			Oregon		
1000212514	5400	11/7	2.960	0.4813	1000164432	6950	3/14	2.567	0.3853
1100213612	5400	11/8	2.111	0.3541	1000164734	6950	3/14	2.513	0.4707
1100213712	5400	11/8	2.477	0.5032	1000164535	6950	3/14	2.774	0.6950
1000215307	5400	11/15	2.858	0.7329					

Table 48d (Continued)

Serial No.	Subject code	Date of measurement	Potassium γ dis/sec/lb	γ ratio Cs/K	Serial No.	Subject code	Date of measurement	Potassium γ dis/sec/lb	γ ratio Cs/K
1000165136	6950	3/14	2.758	0.4901			Utah		
1000186327	6950	7/3	3.362	0.5793	1000187038	4318	7/5	2.860	0.6382
1000193230	6950	8/13	2.943	1.0512	1000189927	4318	7/29	2.989	0.6651
1100209232	6950	10/22	1.987	0.5687	1000201634	4318	9/17	3.169	0.9964
					1000217839	9318	11/29	2.489	0.6101
					1000211833	4318	11/5	2.849	0.5631
							Washington		
1000183635	7555	6/27	2.823	0.6113	1000182339	6128	6/17	2.932	0.4513
1000185023	7555	7/2	2.690	0.9177	1000185734	6128	7/3	3.088	0.9034
					1000186444	6128	7/3	2.070	0.9023
					1000186648	6128	7/3	2.703	1.1110
1000201446	2412	9/10	2.332	0.6109	1100185621	6128	7/3	2.551	0.6163
1100201541	2412	9/10	2.668	0.9991	1000193443	6128	8/13	2.546	0.4916
					1000197328	6128	8/26	3.067	0.4886
					1000197828	6428	8/26	3.021	0.4236
							West Virginia		
1000161428	3555	3/5	2.602	0.6074	1000178930	6510	6/3	2.957	0.7307
1000194538	3555	8/13	2.418	0.4021			Wisconsin		
1000211930	4558	11/5	2.883	0.3714	1000148229	2692	1/18	3.185	0.8680
1000219335	3555	12/9	2.505	0.6700	1000154514	6920	2/5	2.696	0.5006
					1000154446	6920	2/5	2.508	0.4433
					1100154608	6920	2/5	2.749	0.5422
					1100154746	6920	2/5	2.001	0.5946
					1000193725	6920	8/13	2.578	0.5493
							Wyoming		
					1000191539	6860	8/7	2.671	0.6798
					1000202065	6860	9/23	2.359	0.6460
					1000225067	6860	12/27	2.070	1.0196
1000164049	3570	3/14	2.429	0.5730					
1000168717	3570	3/16	2.937	0.2258					
1000187319	3570	7/6	2.693	0.4866					
1000187221	3570	7/6	2.636	0.3067					
1000193830	3570	8/13	2.918	0.4632					
1000202733	3570	9/23	2.489	0.6359					
1000201743	3570	9/23	2.472	0.4580					
1000205340	3570	10/4	2.324	0.6879					
1100224678	3570	12/26	1.589	0.5228					

Table 48e—WHOLE-BODY Cs¹³⁷ MEASUREMENTS, 1957
(Subjects from Outside the United States)

Serial No.	Subject code	Date, 1957	Potassium γ dis/sec/lb	γ ratio Cs/K
Canada				
1000197229	3150	8/26	2.997	0.7678
1000197629	4450	8/26	3.000	0.7373
1000217967	3150	12/2	2.535	0.9416
England				
1000197137	5570	8/26	3.050	0.7800
1000198436	5570	8/27	2.666	0.4663
1000197537	5570	8/26	2.984	0.8412
France				
1000171436	6915	3/26	2.774	0.7865
Germany				
1000171533	7594	3/26	2.862	1.0603
Japan				
1000212032	3575	11/5	2.501	0.3816
Peru				
1000213429	7594	11/8	2.876	0.3507
Sweden				
1000179037	2654	6/3	2.501	0.7087
1000182434	2654	6/18	2.965	0.6615
1000199542	2654	9/3	2.670	0.5678
Thailand				
1000190311	3819	7/30	2.391	0.5346
1000190234	3819	7/30	2.200	0.2606
1100190133	3819	7/30	2.174	0.4691

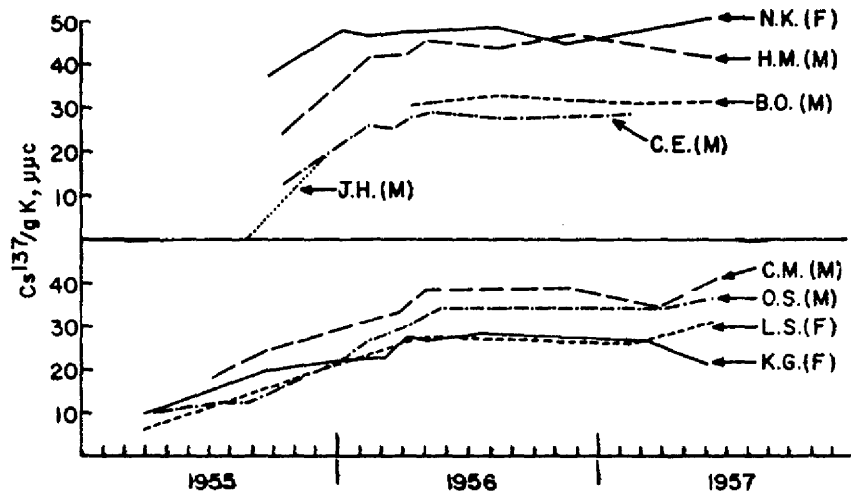

Table 49a—CHICAGO SUBJECTS (42°N)
DURING JUNE 1957

Females	$Cs^{137}/g K, \mu\mu c$	Males	$Cs^{137}/g K, \mu\mu c$
K.G.	22	R.R.	25
L.S.	31	W.P.	28
I.S.	33	B.O.	31
C.L.	36	O.S.	36
J.J.	43	H.M.	41
N.K.	50	C.M.	41
		E.M.	45
	av. 36		av. 35

Table 49b—DATA ON FOREIGN SUBJECTS

Country	Latitude	Date, 1957	Cs ¹³⁷ /g K, $\mu\mu\text{c}$	Country	Subject	Date	Cs ¹³⁷ /g K, $\mu\mu\text{c}$	Zn ⁶⁵ , $\text{m}\mu\text{c}$
Cuba	22°N	5/23	20.0	Europe				
El Salvador	13°N	5/23	8.3	England	T	5/16/56	33.5	
South America				England	R	7/13/56	34.7	
Colombia(4,000)	4°N	5/23	21.0	France	J	9/2/56	32.7	
Ecuador(10,000)	0°N	5/23	13.0	Belgium	F	10/30/56	26.5	
Bolivia(13,000)	15°S	5/23	13.0	Sweden	N	11/29/56	32.2	
Brazil	20°S	5/23	16.0	Australia	P	3/27/57	50.0	
Brazil	30°S	5/23	21.2	Asia				
Uruguay	34°S	5/23	11.6	India	Vo	12/18/56	18.9	
Argentina	35°S	5/23	7.3	India	Vo	12/18/56	20.8	
Argentina	35°S	5/23	7.6	Japan	S	7/26/56	24.5	~ 3.2
Chile	37°S	5/23	22.0	Indonesia	S	8/10/56	13.9	~ 2.1
			av. 14.6	Indonesia	M	8/10/56	8.5	
				Oceania				
				Marshall Islands	RC(U.S.)	4/5/56	26.7	4.2
				Marshall Islands	TT(U.S.)	4/5/56	31.7	5.3
				Marshall Islands	No. 10	4/5/56	65.0	29.5
				Marshall Islands	No. 6	4/5/56	69.0	73.0
				Marshall Islands	No. 9	4/5/56	73.2	29.5
				Marshall Islands	No. 4	4/5/56	79.0	29.5
				Marshall Islands	No. 7	4/5/56	95.5	62.1
				Marshall Islands	No. 5	4/5/56	1610.0	482.0
				Marshall Islands	No. 8	4/5/56	2720.0	229.0
							United States av. 34.0	

THIS PAGE
WAS
INTENTIONALLY
LEFT BLANK
IN
ORIGINAL

Part 2

EXPERIMENTAL INVESTIGATIONS

EXPERIMENTAL INVESTIGATIONS

5. UPTAKE STUDIES

A number of studies which might relate to the uptake of Sr^{90} by plants and animals have been run as field experiments. It must be emphasized that these are not controlled laboratory experiments and that the data are subject to more variability than if strict controls were possible. However, they are part of the data available for interpretation of Sr^{90} analyses and can be of some assistance in predictions of Sr^{90} behavior.

5.1 HASL PASTURE SITE SURVEYS

A series of annual samples has been taken at five sites in the United States by Dr. Lyle T. Alexander of the U. S. Department of Agriculture. The sampling program was begun in 1953, and samples of vegetation, animal bone, and soil have been collected. The intention was to study the relative uptake of Sr^{90} from soils to plant to animal under the most favorable conditions possible. The animal bones in most cases represent yearling lambs or calves that grazed in the same pasture from which the soil and vegetation samples were taken.

It is believed that the major problem in this uptake study is the variability of the Sr^{90} content of the vegetation. The contribution of activity retained on the leaves to the total activity of the plant is quite variable, depending on timing of the collections with respect to the test periods. There is a noticeable general increase in the level of the animal bone from year to year, and this program is continuing.

5.2 CHICAGO MILKSHED AREA SURVEY

Dr. Lyle T. Alexander has collected samples of vegetation and soil at a number of farms in the Chicago area since 1955. In addition, milk samples were also taken in 1956. Since these farms are in active use, it is increasingly difficult to sample soils in unplowed areas and obtain values for top layers and lower layers of the soil.

The vegetation data, as mentioned in the previous section, appear to be more indicative of the Sr^{90} retained on the leaves than of uptake from the soil, since there is no increase with time in the vegetation levels.

5.3 UPTAKE OF Sr^{90} BY BEAN PLANTS

During the summer of 1956, three types of bean plants — snap beans, lima beans, and black-eyed peas — were grown at the Beltsville Laboratory of the U. S. Department of Agriculture. The leaf, stalk, pod, and fruit of each were analyzed separately, and the snap bean and black-eyed peas samples were run in duplicate. The results are given in Table 56.

Normalizing the data to stalk = 1, the mean Strontium Unit (S.U.) values for leaf, fruit, and pod become 0.85, 0.52, and 0.54, respectively. The mean $\text{Sr}^{89}/\text{Sr}^{90}$ ratios are 1.9, 0.2, 0.7, and 1.4 for the leaf, fruit, stalk, and pod. Although such averaging may not be completely justified, it would lead to the following conclusions: (1) The high stalk activity may indicate uptake that is partially blocked from the rest of the plant. (2) The leaves show higher S.U. values than the pod and fruit, indicating some leaf retention. (3) The Sr^{89} values indicate that the leaf and pod activity is younger than the fruit activity.

It is also of interest to note that the Sr^{89} values indicate that some of the top soil activity is younger than the bottom fraction.

5.4 TURNIP EXPERIMENT

An experiment was set up by Dr. Lyle T. Alexander of the U. S. Department of Agriculture to help toward the understanding of the soil to vegetation Sr^{90} cycle. The soil was prepared, and the vegetation was grown at Beltsville, Md. The following design of the experiment was taken from Alexander's memo to files of Aug. 5, 1954:

The three subsoil plots for this experiment were prepared on Saturday and Sunday, July 31 and August 1 by removal of 7 inches of top soil and replacing with material from 7 to 16 inches. From northeast to southeast the plots are in the following order:

1. Subsoil
2. Normal soil
3. Normal soil
4. Top soil
5. Double top soil (not part of experiment)
6. Normal soil
7. Subsoil

The subsoil plots are surrounded by sheet iron 8 inches wide and 6 feet long. The plots are 6x6 feet.

The following materials were incorporated in the soil prior to the rains that preceded seeding:

To the subsoil:

Dolomite, 2.57 lb; high calcium lime, 4/10 lb; 5-10-10, 3 lb; ammonium nitrate, 1/8 lb

To the top soil plots:

Dolomite, 1.65 lb; 5-10-10, 2 lb

Shogoin turnips were seeded on August 5 at the rate of 5 gms. per plot. The seed was imported from Holland in 1951.

5.5 DISTRIBUTION OF Sr^{90} IN ANIMAL BONE

Several tests have been run on the distribution of Sr^{90} in various bones of a single animal. This is important in testing the validity of single samples used to characterize the entire animal. An early series of analyses at HASL showed that for a yearling calf the distribution was uniform except for the hoof.

Additional data are presented in Table 58 to show this uniformity. The variation of Sr^{90} content per gram of calcium is remarkably uniform over the number of bones tested, and it is felt that any of the larger bones of animals, at least for yearlings, is a representative sample of the entire skeleton.

This is not necessarily in disagreement with the data of others indicating nonuniformity in adult human skeletons. In the case of the young animals and probably in the case of children who have lived their entire lives in a contaminated environment, one would expect uniformity. In the case of the adult whose exposure began after formation of the skeleton, it would not be surprising that a considerable degree of nonuniformity would be exhibited.

5.6 Sr^{90} IN HUMAN MILK

A program for determining the concentration of Sr^{90} in human milk was begun in early 1957 at HASL. An attempt was made to obtain samples of the cows' milk comprising a part of the mother's diet at the time. These data are reported in Table 59.

Unfortunately, the quantity of milk obtainable is relatively small, and the error of analysis is correspondingly large. In addition, it was not always possible to obtain the milk sample representing the diet. For the area where the largest number of samples was available (Boston), there are twelve paired values where both the human and cows' milk showed measurable levels. The average ratio of Sr^{90} in human milk compared to that in cows' milk for these twelve samples is 0.37, with a range from 0.22 to 1.5.

This ratio can be considered as only a preliminary estimate since this was not a controlled experiment, and the cows' milk sample is not a complete representation of the diet.

Table 50—HASL PASTURE PROGRAM
(Sr⁹⁰ in soil)

Location	Site	Depth, in.	Sampling date	Available Ca, g/sq ft	Sr ⁹⁰ /sq mile, mc
Tifton, Ga.	Unimproved area	0-6	Sept. 1953	3.4	2.42
	Improved area	0-1	Sept. 1953	0.3	1.02
	Improved area	1-6	Sept. 1953	2.4	<0.41
	Unimproved area	0-2	9/25/54	0.8	3.96
	Unimproved area	2-6	9/25/54	<0.3	0.66
	Improved area	0-2	9/25/54	4.6	3.44
	Improved area	2-6	9/25/54	9.1	≤0.40
	Unimproved area	0-4	11/2/55	1.3	9.99
	Unimproved area	4-8	11/2/55	0.33	0.37
	Improved area	0-2	11/2/55	4.05	8.50
	Improved area	2-6	11/2/55	2.62	1.37
	Unimproved area	0-2	10/22/56	0.56	12.16
	Unimproved area	2-6	10/22/56	0.59	1.98
	Unimproved area	6-12	10/22/56	0.39	0.51
	Unimproved area	12-18	10/22/56	0.45	0.67
	New Brunswick, N. J.		0-1	Sept. 1953	2.7
		1-6	Sept. 1953	14.4	1.11
		6-12	Sept. 1953	12.0	1.62
		0-2	9/11/54	5.22	4.51
		2-6	9/11/54	9.77	0.80
		0-2	10/17/55	6.93	10.24
		2-6	10/17/55	14.01	7.27
Raleigh, N. C.		0-6	10/13/56	10.25	16.09
		0-2	9/23/54		4.06
		2-6	9/23/54		1.45
		0-6	11/1/55	26.0	15.36
		0-2	10/23/56	6.97	12.80
Ithaca, N. Y.		2-6	10/23/56	12.92	3.35
		0-1	Sept. 1953	4.95	1.01
		1-6	Sept. 1953	33.90	0.92
		6-12	Sept. 1953	34.40	≤0.82
		0-2	9/10/54	14.51	3.62
		2-6	9/10/54	43.59	1.52
		0-2	9/14/55	9.4	8.60
		2-6	9/14/55	32.2	3.39
Logan, Utah		0-2	10/12/56	11.98	13.70
		2-6	10/12/56	36.76	7.73
	College Farm	0-1	Sept. 1953	Calcareous	0.66
	College Farm	1-6	Sept. 1953	Calcareous	1.48
	Robinson Farm	0-2	9/18/54	Calcareous	2.60
	Robinson Farm	2-6	9/18/54	Calcareous	1.02
	College Farm	0-2	9/18/54	Calcareous	1.29
	College Farm	2-6	9/18/54	Calcareous	Lost
	College Farm	0-2	10/29/55	34.18	9.92
	College Farm	2-6	10/29/55	81.99	3.70
Mandan, N. D.	College Farm	0-2	11/9/56	17.38	5.98
	College Farm	2-6	11/9/56	77.67	5.40
Mandan, N. D.	Griffin Farm	0-6	Aug. 1956	55.63	10.1
Brawley, Calif.	Irrigation station	0-6	1/5/56	51.8	2.5

Table 51 — HASL PASTURE PROGRAM
(Sr⁹⁰ in hay)

Location	Site	Sampling date	Ca in ash, %	μμc/g Ca
Tifton, Ga.	Unimproved area	Sept. 1954	3.8	30 ± 2
	Improved area	Sept. 1954	5.2	3.9 ± 0.8
	Improved area	June 1955	7.5	34 ± 2
	Improved area	Sept. 1955	6.9	21 ± 1
	Improved area	May 1956	5.6	90.4 ± 2.3
	Improved area	Sept. 1956	5.8	120 ± 10
New Brunswick, N. J.		9/19/54	6.0	9.1 ± 0.4
		7/4/55	7.1	85 ± 2
		Oct. 1955	6.9	77 ± 2
		7/3/56	6.3	87.8 ± 2.1
		10/13/56	9.0	55.9 ± 1.4
Raleigh, N. C.		9/16/54	8.4	26 ± 0.5
		9/1/55	3.5	69 ± 3
	Pig pasture	7/20/56	12.5	38.6 ± 0.3
	Pig pasture	8/4/56	10.3	24.8 ± 0.3
Ithaca, N. Y.		9/10/54	33	0.15 ± 0.07
		6/15/55	13	19 ± 0.8
		9/14/55	12	20 ± 1
		6/7/56	8.1	38.15 ± 0.24
		8/25/56	10.3	15.08 ± 0.27
Logan, Utah	Robinson Farm	9/18/54	7.0	10 ± 0.8
	College Farm	9/18/54	8.2	6.3 ± 0.7
	College Farm	7/18/55	7.5	19 ± 1
	College Farm	6/10/56	16.2	8.08 ± 0.56
Mandan, N. D.		June 1956	15	39 ± 1
		(Silage)	3.7	27 ± 3
		7/1/56	10.3	21 ± 2
Brawley, Calif.	Alfalfa	1/5/56	10.9	2.13 ± 0.22
	Alfalfa	2/28/57	8.9	7.12 ± 0.96

Table 52—HASL PASTURE PROGRAM
(Sr⁹⁰ in bone)

Location	Site or type	Sampling date	μμc/g Ca
Tifton, Ga.	Unimproved area	Fall 1953	3.8
	Unimproved area	Sept. 1954	7.0 ± 0.3
	Improved area	Sept. 1954	2.7 ± 0.2
	Unimproved area	Oct. 1955	12 ± 0.3
	Improved area	Oct. 1955	12 ± 0.3
	Unimproved area	10/24/56	18.9 ± 0.5
	Improved area	10/24/56	9.74 ± 0.35
New Brunswick, N. J.		Fall 1953	1.1
		9/9/54	2.7 ± 0.2
		10/14/55	4.1 ± 0.2
		10/11/56	5.6 ± 0.3
Raleigh, N. C.		Sept. 1954	2.1 ± 0.2
		12/14/55	8.6 ± 0.4
	Sheep	9/19/56	26.2 ± 0.1
	Pig	9/24/56	1.87 ± 0.03
	Pig	9/24/56	1.61 ± 0.04
Ithaca, N. Y.		Sept. 1953	1.1
		9/20/54	2.6 ± 0.2
		9/20/55	5.4 ± 0.3
	Lamb	10/20/56	8.8 ± 0.4
	Lamb	10/20/56	7.8 ± 0.3
	Lamb	10/20/56	10.6 ± 0.4
	Hog	10/20/56	2.66 ± 0.10
	Hog	10/20/56	2.18 ± 0.10
Logan, Utah	Robinson Farm	Fall 1953	1.2
	College Farm	Fall 1953	0.6
	Robinson Farm	Sept. 1954	4.4 ± 0.2
	College Farm	Sept. 1954	1.7 ± 0.2
	College Farm	Oct. 1955	8.2 ± 0.4
	College Farm	May 1956	8.4 ± 0.4
	College Farm	11/13/56	5.3 ± 0.3
Mandan, N. D.	Lamb	3/27/56	24 ± 0.6
		May 1957	26.8 ± 0.5
Brawley, Calif.	Lamb	2/28/57	0.67 ± 0.05

Table 53—CHICAGO PASTURE SITE SURVEY
(Sr⁹⁰ in soil)

Location	Site	Depth, in.	Sampling date	Available Ca, g/sq ft	Sr ⁹⁰ /sq mile, mc
Will Co., Ill.	Van Winkle	0-2	1955	4.4	7.91
	Van Winkle	2-6	1955	5.1	1.41
	Van Winkle	0-2	11/16/56	4.90	15.4
	Van Winkle	2-6	11/16/56	11.57	3.96
	Carver	0-2	1955	3.7	6.60
	Carver	2-6	1955	5.6	2.17
	Carver	0-2	11/16/56	2.33	5.61
	Carver	2-6	11/16/56	8.13	4.35
	Carver	6-12	11/16/56	10.62	1.26
Columbia Co., Wisc.	Premo	0-6	1955	25.5	10.59
	Premo	0-9	11/17/56	34.91	19.8
Dane Co., Wisc.	Lewke	0-8	11/17/56		17.6
Rock Co., Wisc.	Holcomb	0-2	1955	15.0	11.07
	Holcomb	2-6	1955	31.8	3.35
	Holcomb	0-2	11/17/56	6.83	9.56
	Holcomb	2-6	11/17/56		6.45
	Grabow	0-9	11/18/56	19.00	22.00
Winnebago Co., Ill.	Swanson	0-8	1955	82.8	15.57
	Swanson	0-8	11/18/56		26.2
McHenry Co., Ill.	Kurpeski	0-6½	1955	30.9	10.18
	Kurpeski	0-6½	1955	30.5	10.63
	Austin	0-2	1955	6.92	9.55
	Austin	2-6	1955	7.8	2.07
	Austin	0-2	11/18/56	3.44	8.21
	Austin	2-6	11/18/56		5.71
	McKee	0-2	1955		8.45
	McKee	2-6	1955		2.15
	McKee	0-8	11/18/56	139.64	17.0

Table 54—CHICAGO PASTURE SITE SURVEY
(Sr⁹⁰ in hay)

Location	Site	Sampling date	Ca in ash, %	Sr ⁹⁰ , μμc/g Ca
Will Co., Ill.	Van Winkle	10/2/53	21.0	4.98 ± 0.22
		9/29/55	13.2	4.74 ± 0.21
	Carver	10/2/53	25.4	2.31 ± 0.05
		Oct. 1954	26.0	0.87 ± 0.04
		9/29/55	21.0	2.73 ± 0.18
Columbia Co., Wisc.	Premo	9/30/55	17.2	25.5 ± 1.3
		8/15/56	12.7	23.2 ± 0.4
Dane Co., Wisc.	Lewke	9/30/53	6.75	20.9 ± 0.9
		8/15/56	14.6	20.3 ± 0.9
				28.0 ± 1.4
Rock Co., Wisc.	Holcomb	9/29/53	17.4	8.32 ± 0.27
		Oct. 1954	15.3	1.48 ± 0.09
		9/30/55	18.2	19.2 ± 1.0
	Grabow	9/28/53	33.0	12.8 ± 0.3
		7/4/56	11.3	26.8 ± 1.4
Winnebago Co., Wisc.	Swanson	9/29/53	24.1	7.12 ± 0.40
		9/29/55	12.6	13.6 ± 0.8
McHenry Co., Ill.	Kurpeski	9/30/53	27.1	7.44 ± 0.46
		9/29/55	11.8	7.05 ± 0.33
		10/1/53	27.4	4.95 ± 0.27
		Oct. 1954	28.5	0.39 ± 0.02
	Austin	9/29/55	23.0	38.0 ± 2.0
		8/15/56	8.04	42.0 ± 0.5
		10/1/53	22.6	14.8 ± 0.3
		9/29/55	16.3	30.5 ± 1.7
McKee	8/15/56	17.1	26.8 ± 0.4	

Table 55—CHICAGO PASTURE SITE SURVEY
(Sr⁹⁰ in fresh Chicago Milkshed milk)

Sampling date, 1953	Location	Sr ⁹⁰ /g Ca, μμc
9/28	Grabow Farm Rock Co., Wisc.	1.70 ± 0.08
9/29	Swain Farm Rock Co., Wisc.	1.30 ± 0.08
9/29	Swanson Farm Winnebago Co., Ill.	1.21 ± 0.02
9/29	Holcomb Farm Rock Co., Wisc.	1.6 ± 0.1
9/30	Lewke Farm Dane Co., Wisc.	2.25 ± 0.10
9/30	Premo Farm Columbia Co., Wisc.	0.73 ± 0.04
9/30	Kurpeski Farm McHenry Co., Ill.	1.30 ± 0.02
10/1	Austin Farm McHenry Co., Ill.	1.80 ± 0.07
10/1	McKee Farm McHenry Co., Ill.	1.4 ± 0.1
10/1	Blomberg Farm McHenry Co., Ill.	1.19 ± 0.07

Table 56—STUDY OF UPTAKE OF BEAN AND BLACK-EYED PEA PLANTS

Plant	Section	Ca in ash, %	Ca in ash, av. %	Sr ⁹⁰ , μc/g Ca	Av. Sr ⁹⁰ , μc/g Ca	Sr ⁸⁹ */Sr ⁹⁰ ratio	
Snap bean 1st half bag	Leaf	12	12	76 ± 1.7	78	3.0	
		11		80 ± 1.8		2.9	
	Bean	1.4	1.4	65 ± 5.9	58	0.87	
		1.4		52 ± 8.6		0.79	
	Stalk	14	14	82 ± 1.5	81	1.2	
		15		80 ± 1.4		1.1	
	Pod	9.3	8.6	53 ± 1.7	57	1.6	
		8.0		61 ± 3.1		1.4	
	*As of 10-15-56						
	2nd half bag	Leaf	3.8	4.0	45 ± 4	48	2.0
4.2				50 ± 3	1.4		
Bean		1.6	1.7	43 ± 9	37		
		1.8		30 ± 5		0.60	
Stalk		15	16	68 ± 1.8	66	0.39	
		16		64 ± 1.8		0.44	
Pod		7.9	7.9	55 ± 2	55	0.56	
		7.8		55 ± 2		0.38	
*As of 1-21-57							
Lima bean	Leaf	15	15	35 ± 1.4	36	0.99	
		14		36 ± 0.9		0.98	
	Bean	1.5	1.5	6.4 ± 5.9	11		
		1.4		15 ± 7.3			
	Stalk	14	15	45 ± 1.4	42	0.20	
		15		39 ± 1.4		0.16	
	Pod	7.7	7.9	4.5 ± 1.8	3.8		
		8.1		3.0 ± 2.3			
*As of 1-24-57							
Black-eyed pea	Leaf	22	23	33 ± 0.9	54	1.7	
		23		34 ± 0.9		1.8	
	Bag 1	Bean	1.7	1.9	21 ± 6.4	24	
			2.0		27 ± 5.9		
	Stalk	8.4		34 ± 1.8		0.64	
		7.9		38 ± 1.8		0.37	
		7.9	8.0	35 ± 1.8	37	0.70	
		7.7		41 ± 2.3		0.82	
	Pod	8.1	8.2	21 ± 1.4	22	2.3	
		8.2		23 ± 1.8		2.1	
	*As of 1-23-57						
	Bag 2	Leaf	21	20	28 ± 0.9	31	2.3
19				34 ± 1.4	2.0		
Bean		2.0	2.0	18 ± 5.0	16		
		2.0		13 ± 4.5			
Stalk		6.2	8.1	48 ± 2.7	39	1.1	
		10		30 ± 1.8		1.0	
*As of 1-22-57							

Table 56 (Continued)

Radiostrontium and Calcium in Soil from the Bean and Pea Plant Plots

Depth, in.	Ca, g/soil, g	Sr ⁹⁰ , dis/min/g of soil	Sr ⁹⁰ , μμc/g Ca	Sr ⁹⁰ , mc/sq mile	Sr ⁸⁹ /Sr ⁹⁰ ratio	Sr ⁸⁹ , C date
0-2	89 × 10 ⁻⁶	0.080 ± 0.004	410 ± 2.0	6.0 ± 0.3		
	62 × 10 ⁻⁶	0.083 ± 0.005	610 ± 3.7	6.2 ± 3.7		
	80 × 10 ⁻⁶	0.077 ± 0.004	440 ± 2.3	5.8 ± 0.3		
		0.071 ± 0.006		5.3 ± 0.4	3.0	12/27/56
		0.090 ± 0.008		6.8 ± 0.6	2.3	12/27/56
2-6	68 × 10 ⁻⁶					

Table 57—TURNIP EXPERIMENT

Plot No.	Sr ⁹⁰ , dis/min/g of soil	Sr ⁹⁰ , dis/min/g of Ca	Sr ⁹⁰ /g Ca, μμc
1. Soil [received as Calcium Oxalate (NH ₄ Ac Leach)]			
1	5.8 × 10 ⁻³ ± 8.3 × 10 ⁻⁴	16.2 ± 2.3	7.4 ± 1.0
2	7.4 × 10 ⁻³ ± 0.8 × 10 ⁻³	12.8 ± 1.4	5.8 ± 0.6
3	1.8 × 10 ⁻³ ± 0.7 × 10 ⁻³	5.2 ± 2.0	2.4 ± 0.9
4	4.4 × 10 ⁻³ ± 0.7 × 10 ⁻³	7.2 ± 1.3	3.3 ± 0.6
6	7.3 × 10 ⁻³ ± 0.8 × 10 ⁻³	11.6 ± 1.3	5.3 ± 0.6
7	4.3 × 10 ⁻³ ± 0.7 × 10 ⁻³	8.8 ± 1.1	4.0 ± 0.5
2. Vegetation (1st cutting Sept. 21, 1954)			
1	8.0	0.02 ± 0.09	0.11 ± 0.51
2	6.0	0.21 ± 0.10	1.59 ± 0.84
3	7.6	0.25 ± 0.088	1.50 ± 0.53
4	8.0	0.08 ± 0.08	0.45 ± 0.45
6	8.8	0.47 ± 0.11	2.43 ± 0.57
7	8.6	0.39 ± 0.1	2.06 ± 0.53
(2nd cutting Nov. 4, 1954)			
1	11.0	0.25 ± 0.09	1.03 ± 0.37
2	11.0	0.27 ± 0.08	1.11 ± 0.33
3	13.2	1.63 ± 0.13	5.59 ± 0.44
4	11.0	0.0 ± 0.1	0.0 ± 0.1
6	11.0	1.26 ± 0.09	5.23 ± 0.37
7	11.0	1.44 ± 0.10	5.95 ± 0.41

Table 58—DISTRIBUTION STUDY OF Sr⁹⁰ IN ANIMAL BONE

(Lamb: born, 9/10/55; slaughtered, 10/11/56;

Rutgers University, New Brunswick, N. J.)

Type	Ca in ash, %	Sr ⁹⁰ , μμc/g Ca
Vertebra	35.6	7.5 ± 0.3
Femur	35.3	7.2 ± 0.3
Pelvic	35.8	7.5 ± 0.3
Ribs	34.5	7.7 ± 0.3
Shoulder Blade	34.6	8.4 ± 0.3
Shoulder Blade	34.3	7.4 ± 0.3

Table 59 — SAMPLES OF Sr⁹⁰ IN MILK

HASL sample No.	City sample No.	Age, years	Sample date, 1957	Mother's Milk, Sr ⁹⁰ /g Ca, $\mu\mu\text{c}$	Cow's Milk, Sr ⁹⁰ /g Ca, $\mu\mu\text{c}$	Mother's Milk, Ca/liter, mg	Cow's Milk, Ca/liter, mg
Boston, Mass.							
6047	31	22		2.18 ± 1.65		248	
6048					7.08 ± 0.48		1031
6049	32	25		≤ 1.38		274	
6050					2.73 ± 0.44		1023
6051	33	18½		≤ 1.27		259	
6052					lost		
5677	26	25	March	3.42 ± 1.64		263	
5676					5.68 ± 0.52		960
5679	27	29	March	1.71 ± 1.09		290	
5678			April		6.18 ± 0.59		736
5681	28	24	March	≤ 1.22		266	
5680			April		4.84		1052
5683	29	32	March	2.06 ± 1.23		292	
5682					1.98 ± 0.4		1024
5325			February	3.85 ± 2.13		263	
5326	10		February	lost			
5328					3.54 ± 0.87		794
5327	22		February	≤ 2.37		274	
5330					6.44 ± 0.76		1492
5555	20	25	March	2.00 ± 1.27		315	
5556					4.80 ± 0.63		797
5557	24	33	February	≤ 2.40		225	
5558					5.24 ± 0.58		1005
5329 (c)	16				3.97 ± 0.95		978
5554	18	23	February	≤ 1.31		305	
6396	35	34	June				
6399					7.82		698
6398	37	24	June	6.11		237	
6401					3.23		959
6400	36	30	June	≤ 5.13		210	
6397					1.52		908
6558	38	25	July	3.62		273	
6559					7.71		1039
6560	39	25	July	0.81		301	
6561					3.69		1216
6562	40	24	July	0.51			279
6563							
6564	41	27	July	2.45		295	
6565					5.25		726
6685	42	32	July	1.19		298	
6686					5.29		906
6687	43	22	July	≤ 2.07		290	
6688					6.45		988
6689	44	29	August	≤ 3.55		318	
6690					5.56		1000
6691	46	33	August	2.30		272	
6692					7.06		941
6934	47	23	September	0.65		196	
6935							
6936	49	34	September				
6937					5.29		899
6938	50	24	September				
6939					6.55		915
7064	52	24	September	2.95		111	
7065							
7068	54	27	October				
7069					5.57		1526
7097	55	19	October	1.76		148	
7098					6.10		884
7099	56	19	October	≤ 1.24		255	
7100					5.33		1026

Table 59—(Continued)

HASL sample No.	City sample No.	Age, years	Sample date, 1957	Mother's Milk, Sr ⁹⁰ /g Ca, $\mu\mu\text{c}$	Cow's Milk, Sr ⁹⁰ /g Ca, $\mu\mu\text{c}$	Mother's Milk, Ca/liter, mg	Cow's Milk, Ca/liter, mg
7101	57	25	October	0.47		254	
7102							
Los Angeles, Calif.							
6606			July	2.00		315	
6607					0.75		318
6608			July	0.80		269	
6609					2.26		1080
6679			August	4.34		253	
6680					1.10		1055
6681			August	≤ 3.55		226	
6682			July		0.61		945
6998			September				
6999							869
7000			September	4.49		348	
7001							940
San Francisco, Calif.							
6409	1			0.96		264	
6410							
6411	2			27.8		278	
6412					4.63		734
6413	3			1.21		278	
6414					6.67		682
6415	4				0.46		863
6416						207	
6417	5				8.91		906
6418							
6552	6			1.39		264	
6553					1.75		961
6554	7						
6555				2.33	2.33		1028
6556	8			1.94		252	
6557					0.61		800
6726	4			9.41		207	
6727							890
6728	7			3.46		165	
6729							933
6730	9			0.13		202	
6731							
6884	8					261	
6885							
6886	12					316	
6887							447
6888	13					179	
6889							269
6985	14			≤ 1.94		198	
6986							
6987	15			3.04		220	
6988							
6989	16			2.53		574	
6990							858
6991	17			2.88		228	
6992							
7133	11			1.09		260	
7134							1078
7135	17			0.77		190	
7136							967
7230	13						
7231							1036
7232	16						
7233							769

6. FALLOUT MECHANISM

There is need for more basic knowledge on the mechanism of fallout. Theoretical treatment of the deposition process is possible, but there is little information on the primary characteristics of the radioactive material that constitutes long-range fallout. Certain general observations have been made and are generally agreed upon:

1. The Sr^{90} in fallout is largely water soluble, although fallout debris consisting of silicate materials from continental tests may have a larger fraction that is water insoluble.
2. Eighty to ninety per cent of the Sr^{90} fallout, and presumably of total radioactive fallout, comes down during periods of precipitation and only 10 to 20 per cent is deposited by dry fallout.
3. Radioactive debris injected into the troposphere is deposited within a few months, whereas material injected in the stratosphere may have a residence time of several years.
4. There is a marked latitudinal variation in fallout, apparently greater than can be explained on the basis of tropospheric fallout being confined to a narrow zone of latitude.

There are many details of deposition, however, which are not fully understood, and some experimental work is in progress to study fallout mechanisms. The data reported in this section are results of relatively small, short-term experiments intended to point the way toward more extended work if the approach appears promising. Those projects that are being continued will be mentioned in the discussion relating to the individual study.

6.1 PRECIPITATION SAMPLES COLLECTED AT MOUNT WASHINGTON OBSERVATORY

A number of preliminary samples consisting of condensed fog and precipitation have been collected at the Mount Washington Observatory. These have been taken to determine whether there is a relation between cloud content and precipitation content for Sr^{90} . The results are only preliminary, but a more definite program is under way at the present time.

6.2 NEW HAVEN DUSTFALL

The Bureau of Environmental Sanitation of the New Haven Department of Health collects monthly dustfall samples at several stations in and around the city. The collectors are standard 1500-ml beakers, and duplicate samples are analyzed for dust content, one by evaporation of any rainfall and the other by filtration. During 1956, certain samples supplied to HASL were measured for total MFP activity and Sr^{90} , and the results are shown in Table 61.

Although the data are not as complete as desired, there are several interesting points: (1) filtration or evaporation is equally effective for dustfall by weight, (2) filtration loses both MFP and Sr^{90} by solubility, and (3) the agreement in activity values between stations is fairly good and is independent of the dustfall.

6.3 FALLOUT COLLECTIONS IN HARTFORD, CONN., AREA

A series of monthly pot collections was made in the Hartford, Conn., area to determine the variability in local fallout around an industrial city. The data are presented in Table 62, and the location of the stations are mapped in Fig. 14.

There is no apparent significant difference between the locations, although there is considerable variation in fallout level from place to place. The variation does not seem to be related to precipitation or any other known variable.

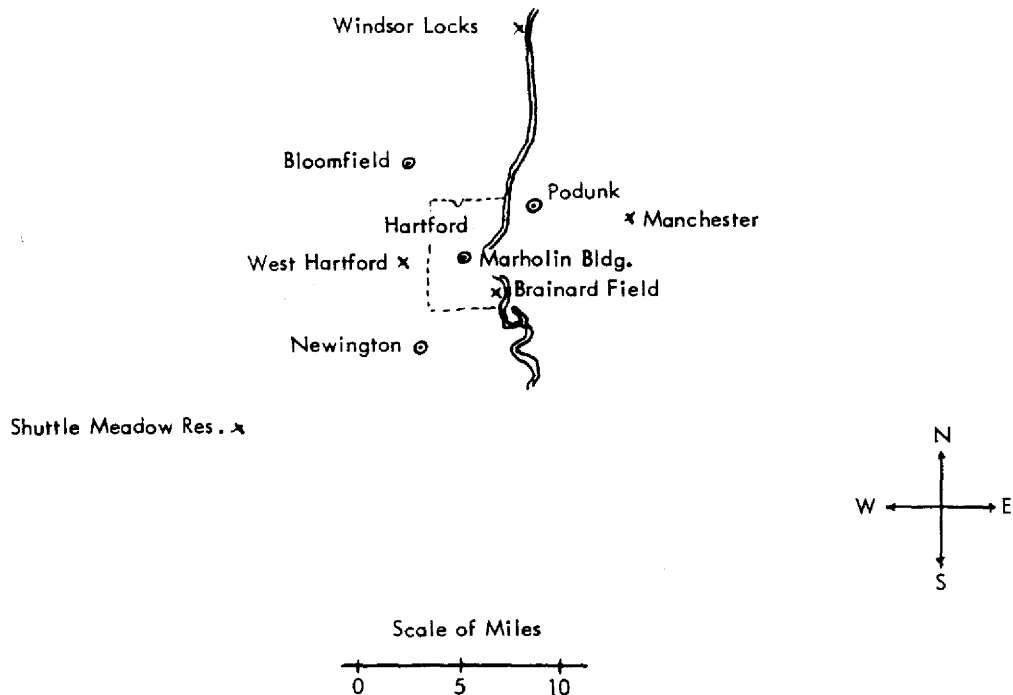

Fig. 14—Pot fallout collections in the Hartford area. \odot , pot fallout collecting stations; \times , rain measurement stations.

6.4 Sr^{90} IN ANTARCTIC SNOW

Certain snow cores and surface snow samples were collected in the Antarctic in early 1955. The Sr^{90} determinations on these samples are reported in Table 63. A number of additional samples for both Sr^{90} and tritium analysis have been collected during the present International Geophysical Year operations in the Antarctic, but analytical data are not yet available.

6.5 Sr^{90} IN U. S. WEATHER BUREAU POLAR OPERATIONS SNOW SAMPLES

Analyses for total beta activity, Sr^{89} , and Sr^{90} were carried out on melted snow samples forwarded to HASL through the U. S. Weather Bureau. These samples were collected during the spring and summer of 1956 in conjunction with a U. S. Weather Bureau Polar Operations Project. The data are shown in Table 64.

6.6 Sr^{90} IN NEVADA SOIL SAMPLES

A group of soils collected in Nevada during 1953 and 1954 were submitted to HASL for Sr^{90} determination by Dr. Kermit Larson, Atomic Energy Project, University of California in West Los Angeles. The results of these analyses are reported in Table 65.

6.7 Sr^{90} IN HAWAIIAN AIR SAMPLES

A series of air samples have been taken in Hawaii on Mount Haleakala and Mauna Loa. The altitudes are about 10,000 ft, and the samples were collected by Dr. Hans Pettersson of Sweden, whose basic interest is in meteoric dust. The locations are quite free from terrestrial dust and are, therefore, of interest in sampling both for meteoric debris and radioactive particulates. The results of these measurements are given in Table 66.

6.8 Sr⁹⁰ FALLOUT COLLECTIONS ON WEATHER SHIPS

The relative fallout on the open ocean compared to that on the land has not been definitely measured. Most of the suitable island sampling locations are of sufficient size to cause changes in the micrometeorology and to give results that may perhaps be different from that on the ocean surface itself. The U. S. Weather Bureau, through Dr. Lester Machta of the Special Projects Branch, has begun collections on the stationary weather ships in the Atlantic and will begin collections in the Pacific. These ships are on station for approximately six weeks, and open pot type collections are made during this period. The actual collection units are those developed by the Air Force Cambridge Research Center and loaned to the Weather Bureau for this work.

The data are not available for a long enough period to give reliable comparison with shore stations; however, the available results are tabulated in Table 67.

Table 60—PRECIPITATION COLLECTIONS AT MT. WASHINGTON OBSERVATORY

Sampling dates	Sampling interval, hr	Total volume, liters	Type	Total β activity, dis/min/liter	C date	Sr^{90} , dis/min/liter
1956					1956	
7/8-7/9	8.2	3.660		32.8 ± 2.6	9/7	2.18 ± 0.41
7/9	8.5	4.100		36.6 ± 2.4	9/7	0.71 ± 0.22
7/9	6.3	1.530		98.0 ± 7.2	9/7	2.29 ± 0.65
7/10-7/11	24	4.050		lost	9/7	lost
7/11-7/12	21	1.980		343 ± 8	9/7	9.09 ± 0.91
8/10	14	4.050		141 ± 4	11/28	lost
8/14-8/15	17	4.070		172 ± 5	11/28	7.62 ± 0.98
8/22-8/23	27	4.090		191 ± 5	11/28	10.0 ± 0.8
8/26-8/27	24	4.120		150 ± 5	11/28	4.51 ± 0.73
8/30-8/31	24	4.040		71.8 ± 3.2	11/28	1.44 ± 0.64
9/2	5.0	4.040		139 ± 4	11/28	3.46 ± 0.89
9/16-9/17	24	4.040		122 ± 4	11/28	2.10 ± 0.44
9/30	16	4.090		367 ± 9	11/28	4.64 ± 0.88
10/5	12	4.0				4.72 ± 0.22
10/7	10	4.0				4.35 ± 0.10
10/31-11/1	24	4.0				2.88 ± 0.15
1957					1957	
2/10	6	4.0				2.00 ± 0.14
5/24	11.7	3.0	Rain & cloud water (30% rain)	243 ± 23	9/14	17.8 ± 1.7
5/24		1.0		20.2 ± 7.1	8/22	2.2 ± 0.7
6/4-6/5	24	1.5	Rain & cloud water (2% rain)	573 ± 53	9/14	40.7 ± 4.0
6/27-6/28	24	4.0	Rain & cloud water (1/2% rain)	165 ± 18	9/20	18.5 ± 1.0
6/28	2.2	3.0	Rain & cloud water (95% rain)	70 ± 10	9/20	5.73 ± 0.50
6/28-6/29	24	4.0	Rain & cloud water (1/2% rain)	182 ± 20	9/20	12.2 ± 0.6
6/29	11.4	4.0	Rain & fog water (85% rain)	14.1 ± 2.1	8/22	0.30 ± 0.22
7/2-7/3	24	4.0	Rain & fog water (60% rain)	95.1 ± 3.2	8/22	5.80 ± 0.35
7/3-7/4	24	4.0	Rain & fog water (75% rain)	58.8 ± 2.6	8/22	1.90 ± 0.22
7/22-7/23	24	3.0	Rain & fog water (95% rain)	86.8 ± 4.2	8/22	2.83 ± 0.31
8/17-8/18		3.578				46.5 ± 0.4
9/20-9/21		3.539				7.01 ± 0.16
11/1		4.060				6.26 ± 0.19
11/1-11/2		3.990				2.81 ± 0.11
11/2		4.015				2.70 ± 0.13
11/2		4.080				2.23 ± 0.13
11/2		4.060				1.60 ± 0.07

Table 61—NEW HAVEN DUSTFALL EXPERIMENT

Sampling station	March			April			May		
	Total β activity, mc/sq mile	Sr^{90} mc/sq mile	Dust, g	Total β activity, mc/sq mile	Sr^{90} mc/sq mile	Dust, g	Total β activity, mc/sq mile	Sr^{90} mc/sq mile	Dust, g
Airport No. 1									
evaporation				55.55 \pm 1.37*	2.1 \pm 0.26	0.077	40.17 \pm 1.28*	0.49 \pm 0.31	0.072
filtration	11.11 \pm 0.85*	0.20 \pm 0.05	0.035	26.49 \pm 1.11*	0.14 \pm 0.06	0.075	17.95 \pm 0.94*	0.38 \pm 0.09	0.046
Airport No. 2									
evaporation									
filtration	10.26 \pm 0.85*	0.09 \pm 0.06	0.025						
St. Rose's Convent									
evaporation				48.71 \pm 1.54*	1.7 \pm 0.32	0.167	43.58 \pm 1.37*	0.70 \pm 0.32	0.128
filtration	14.53 \pm 0.94*	0.23 \pm 0.05	0.110	29.05 \pm 1.19*	0.25 \pm 0.1	0.159	15.38 \pm 0.85*	0.18 \pm 0.07	0.112
Hall of Records									
evaporation				70.93 \pm 1.54*	1.4 \pm 0.08	0.143			
filtration	15.38 \pm 0.94*	0.14 \pm 0.06	0.096	Lost	0.14 \pm 0.05	0.114	23.92 \pm 1.11*	0.34 \pm 0.08	0.116
Edward Malley Co., Bldg.									
evaporation				69.22 \pm 1.62*	1.6 \pm 0.12	0.130			
filtration	16.24 \pm 0.94†	0.37 \pm 0.11	0.106	23.07 \pm 1.11*	\leq 0.08	0.111	17.09 \pm 0.85*	0.34 \pm 0.06	0.090
Brady Memorial Lab.									
evaporation									
filtration	12.82 \pm 0.85†	0.21 \pm 0.07	0.206						
New Haven Hospital									
evaporation				63.24 \pm 1.62*	0.94 \pm 0.29	0.109			
filtration	11.96 \pm 0.85†	0.14 \pm 0.06	0.081	25.64 \pm 1.03†	0.09 \pm 0.07	0.090	17.09 \pm 0.94*	0.71 \pm 0.06	0.059
Grace-N.H. Memorial Bldg.									
evaporation				68.37 \pm 1.71*	6.0 \pm 0.37	0.109			
filtration				27.35 \pm 1.03†	0.14 \pm 0.05	0.100	15.38 \pm 0.94*	0.39 \pm 0.07	0.068

Table 61 — (Continued)

Sampling station	June			July			August		
	Total β activity, mc/sq mile	Sr^{90} , mc/sq mile	Dust, g	Total β activity, mc/sq mile	Sr^{90} , mc/sq mile	Dust, g	Total β activity, mc/sq mile	Sr^{90} , mc/sq mile	Dust, g
Airport No. 1									
evaporation	25.64 \pm 1.28†	0.53 \pm 0.06	0.054				Lost	0.51 \pm 0.07	
filtration	12.82 \pm 0.85†	0.34 \pm 0.06	0.046	23.07 \pm 1.11‡	0.25 \pm 0.06	0.028	7.61 \pm 0.72§	\leq 0.10	0.015
Airport No. 2									
evaporation									
filtration									
St. Rose's Convent									
evaporation	31.62 \pm 1.19†	0.66 \pm 0.08	0.163				Lost	0.57 \pm 0.07	
filtration	19.66 \pm 1.03†	0.53 \pm 0.06	0.157	30.77 \pm 1.20‡	0.17 \pm 0.06	0.095	8.38 \pm 0.77§	0.17 \pm 0.06	0.122
Hall of Records									
evaporation	26.49 \pm 1.11†	0.69 \pm 0.09	0.110						
filtration	16.24 \pm 1.03†	0.50 \pm 0.12	0.112	32.47 \pm 1.20‡	0.26 \pm 0.1	0.080	9.40 \pm 0.77§	0.18 \pm 0.10	0.075
Edward Malley Co., Bldg.									
evaporation	30.76 \pm 1.20†	0.60 \pm 0.06	0.098						
filtration	16.24 \pm 0.85†	0.42 \pm 0.06	0.096	22.22 \pm 1.03‡	0.15 \pm 0.06	0.067	6.92 \pm 0.73§	0.14 \pm 0.06	0.066
Brady Memorial Lab.									
evaporation									
filtration									
New Haven Hospital									
evaporation									
filtration									
Grace-N.H. Memorial Bldg.									
evaporation	26.49 \pm 1.20†	0.36 \pm 0.06	0.104				Lost	0.51 \pm 0.07	
filtration	17.09 \pm 0.94†	0.49 \pm 0.08	0.079	26.49 \pm 1.03‡	0.25 \pm 0.05	0.069	8.38 \pm 0.68§	0.40 \pm 0.10	0.034
Grace-N.H. Memorial Bldg.									
evaporation	24.78 \pm 0.94†	0.54 \pm 0.11	0.062						
filtration	15.38 \pm 0.94†	0.37 \pm 0.08	0.064	37.60 \pm 1.37‡	0.22 \pm 0.05	0.046	6.24 \pm 0.64§	0.19 \pm 0.06	0.053

*Counting date: 7-17-56.

†Counting date: 7-24-56.

‡Counting date: 8-24-56.

§Counting date: 11-7-56.

Table 62—FALLOUT COLLECTIONS IN THE HARTFORD, CONN., AREA
(Pot Collections from April 1957 to August 1957)

		Middle of April to April 26	April 26 to June 7	June 7 to July 5	July 5 to August 8			
A. Sr⁹⁰, mc/sq mile								
Hartford								
a		0.97	0.58	0.52	0.76			
b		0.82	0.87	0.74	0.75			
Newington								
a		0.17	0.26	0.53	0.58			
b		0.20						
Podunk		0.70	0.74	0.42	0.93			
Bloomfield		0.59	0.74	0.31	0.61			
B. Sr⁸⁹/Sr⁹⁰, as of end of sampling period.								
Hartford								
a		18	7.2	Not analyzed	20			
b		12	11	Not analyzed	23			
Newington								
a		8.1	12	Not analyzed	24			
b		8.5		Not analyzed				
Podunk		21	9.2	Not analyzed	23			
Bloomfield		28	9.2	Not analyzed	23			
C. Total β activity, mc/sq mile								
	C date	Middle of April to April 26	C date	April 26 to June 7	C date	June 7 to July 5	C date	July 5 to August 8
Hartford								
a	5-4-57	225	6-17-57	94.8	7-30-57	73.7	8-15-57	209
b	5-4-57	312	6-17-57	74.6	7-30-57	61.5	8-15-57	309
Newington								
a	5-4-57	14.6	6-17-57	75.8	7-30-57	66.3	8-15-57	171
b	5-4-57	31.4	6-17-57		7-30-57		7-15-57	
Podunk	5-4-57	202	6-17-57	79.4	7-30-57	35.3	7-15-57	299
Bloomfield	5-4-57	266	6-17-57	64.0	7-30-57	33.9	7-15-57	142
		HASL Nos.		HASL Nos.		HASL Nos.		HASL Nos.
		5862 to		6013 to		6353 to		6648 to
		5868		6017		6357		6651

Table 63—ANTARCTIC SNOW
(Snow cores and surface snow samples collected in
Antarctica during January and February 1955)

Sample No.	Depth, ft	Volume, liters	Sr ⁹⁰ /liter, dis/min	
A. Snow core, Admiral Byrd Bay, 69°34'S, 00°41'W, collected Feb. 19, 1955; core cross section: 7 × 7 in.				
CL 605	0-1	3.37	1.95 ± 0.20	
CL 606	1-2	3.10	1.7 ± 0.2	
CL 607	2-3	2.96	0.48 ± 0.04	
CL 602	3-4	3.96	0.90 ± 0.06	
CL 603	4-5	3.37	≤ 0.48	
CL 604	5-6	3.70	0.29 ± 0.03	
B. Snow core, Little America III, 78°S, 170°W, collected Jan. 15, 1955; core cross section: 7 × 7 in.				
CL 608	0-1	2.67	0.34 ± 0.10	
CL 609	1-2	2.56	1.35 ± 0.26	
CL 610	2-3	2.96	0.5 ± 0.1	
CL 611	3-6	7.65	≤ 0.30	
C. Surface samples, 0-8-in. depth.				
Sample No.	Location	Collection date	Volume, liters	Sr ⁹⁰ /liter, dis/min
CL 612	Near Quonset, Little America III	1/15	11.30	3.2 ± 0.3
CL 613	½ mile E. Little America III	1/17	15.85	3.1 ± 0.7
CL 614	6 miles inland on ice shelf, Atka Bay, 70°35'S, 08°06'W	February	5.44	5.3 ± 0.5

Table 64—SNOW SAMPLES
(Collected by U. S. Weather Bureau, Polar Operations Project, 1956)

HASL No.	Sampling dates	Location	Water, liters	Total β Activity		Sr^{90}		Sr^{90} , $\mu\mu\text{c/liter}$	Remarks
				C date, 1957	Dis/min/liter	C date, 1957	Dis/min/liter		
4435		Eureka Sound	4.0	9/14	28 \pm 5	10/29	≤ 1.2	≤ 0.13	
5155	5/12-6/11	Resolute Bay	8.0	9/14	28 \pm 4	10/7	≤ 0.4	4.77 \pm 0.27	
5154	5/18	Resolute Bay	7.7	9/14	9.13 \pm 1.96	9/27	≤ 0.4	1.82 \pm 0.23	
5156	8/28	Eureka Sound	8.0	9/15	5.0 \pm 1.9	10/7	≤ 0.25	0.18 \pm 0.07	Lat 79° 59'N; long 85° 55'W: ~600 ft ² at av. depth of 1/2 in.
5157	8/29	Jones Sound, Ellesmere Island	8.0	9/20	11 \pm 3	10/7	0.8 \pm 0.5	0.36 \pm 0.04	Lat 76° 24'N; long 88° 12'W: depth on ground 7 in. collected top 6 in. over a 12 sq ft area 50 ft above sea level, 1/2 mile from beach line in center of valley (1 mile wide by 5 miles long— axis of valley north and south).
5152	8/29	Icebreaker Iberville	8.0	9/20	51 \pm 6	10/7	≤ 1.2	2.7 \pm 0.3	Lat 75° 50'N; long 80°W: collected 500 sq ft on upper bridge, precipitation 10 in.
5153	8/31	River Clyde, Baffin Island	8.0	9/20	245 \pm 20	9/27	≤ 0.4	0.96 \pm 0.05	Lat 70° 30'N; long 68° 40'W: collected from residual snow drift about 4 miles NW of island; average depth 2 in., covering an area of approximately 36 sq ft.

Table 65 — Sr⁹⁰ IN NEVADA SOIL SAMPLES
 (NYE area, ~ 12 miles from test site; Riverside area, ~ 100 miles from test site)

UCLA No.	HASL No.	Collection date	UCLA radio assay date	UCLA radio assay, dis/min/g	HASL Sr ⁹⁰ , dis/min/g of soil
NYE1, 11	447	7/3/53	8/17/54	17,381	
1					114 ± 1.6
2					190 ± 2.0
Av.					152 ± 1.1
NYE-L-1	448	7/3/53	8/17/54	12,358	
1					72 ± 1.8
2					69 ± 1.4
Av.					70 ± 1.3
NYE-D-1	449	7/3/53	8/17/54	12,896	
1					89 ± 1.2
2					101 ± 1.4
Av.					95 ± 0.8
NYE-J-1	450	7/3/53	8/17/54	14,882	
1					96 ± 1.6
2					34 ± 2.0
Av.					65 ± 1.1
NYE-I-G-1	451	7/3/53	8/17/54	13,774	
1					99 ± 0.1
2					124 ± 1.2
Av.					112 ± 0.1
NYE-I-C-1	452	7/3/53	8/17/54	16,825	
1					116 ± 1.3
2					135 ± 1.7
Av.					126 ± 0.9
NYE-I-H-1	453	7/3/53	8/17/54	11,531	
1					74 ± 0.1
2					77 ± 0.2
Av.					76 ± 0.1
NYE-1-B-1	456	7/3/53	8/16/54	23,148	
1					182 ± 0.2
2					146 ± 0.1
Av.					164 ± 0.2
NYE-1E-1	458	7/3/53	8/17/54	18,700	
1					34 ± 1.2
2					120 ± 2.0
Av.					77 ± 0.8
NYE-1-K-1	462	7/3/53	8/17/54	19,700	
1					74 ± 1.7
2					49 ± 1.5
Av.					62 ± 1.2
NYE-1-A-1	465	7/3/53	8/17/54	21,682	
1					75 ± 1.7
2					137 ± 2.2
Av.					106 ± 1.2

Table 65—(Continued)

UCLA No.	HASL No.	Collection date	UCLA radio assay date	UCLA radio assay, dis/min/g	HASL Sr ⁹⁰ , dis/min/g of soil
NYE-1-F-1	466	7/3/53	8/17/54	13,542	
1					102 ± 1.8
2					61 ± 1.5
Av.					82 ± 1.3
Riverside A-1	454	5/25/54	8/13/54	565	
1					9.0 ± 0.6
2					4.3 ± 0.5
Av.					6.6 ± 0.4
Riverside D-1	457	5/25/54	8/13/54	738	
1					4.6 ± 0.5
2					6.2 ± 0.5
Av.					5.4 ± 0.4
Riverside C-1	459	5/24/54	8/12/54	649	
1					4.6 ± 0.5
2					3.2 ± 0.5
Av.					3.9 ± 0.4
Riverside B-1	463	5/23/54	8/12/54	352	
1					5.0 ± 0.5
2					1.3 ± 0.5
Av.					3.2 ± 0.4
Riverside E-1	464	5/25/54	8/13/54	424	
1					3.7 ± 0.5
2					5.5 ± 0.5
Av.					4.6 ± 0.4
Riverside F-1	467	5/25/54	8/14/54	458	
1					2.6 ± 0.5
2					
Av.					

Table 66—AIR FILTERS—HAWAII

HASL No.	Date, 1957	Sample time, hr	Volume, cu ft	Sr ⁹⁰ , dis/min/s	Sr ⁸⁹ , dis/min/s	C date, 1957	Sr ⁸⁹ /Sr ⁹⁰ ratio
5661 (g)	2/5	21	19,500	4.9 ± 1.2	5.35 ± 4.53		1.09 ± 0.96
5662 (g)	2/22	25	25,000	20.2 ± 1.7	66.0 ± 6.28		3.27 ± 0.42
5663 (g)	2/23	24	18,000	18.1 ± 1.5	83.46 ± 5.79		4.61 ± 0.5
5664 (p)	2/5	24	?	2.6 ± 0.89	5.58 ± 4.18		2.15 ± 1.78
5665 (p)	2/28	24	18,720	2.9 ± 0.9	3.82 ± 4.16		1.32 ± 1.49
	3/1						
5666 (g)	3/5	24	23,760	15.2 ± 1.4	70.14 ± 5.72		4.61 ± 0.57
5667 (g)	2/28	24	23,760	5.4 ± 1.2	17.90 ± 4.83		3.31 ± 1.16
5668 (p)	3/7	24	24,480	2.8 ± 1.2	8.35 ± 4.94		2.98 ± 2.18
5669 (g)	3/7	24	23,040	5.4 ± 1.1	39.15 ± 4.98		7.25 ± 1.74
5670 (g)	3/11	24	23,040	2.2 ± 0.9	4.83 ± 4.17		2.19 ± 2.09
5671 (p)	3/11	24	?	1.3 ± 0.9	0.11 ± 3.94		0.085 ± 3.04
5672 (g)	3/14	24	22,320	4.9 ± 1.9	22.11 ± 4.82		4.51 ± 1.41
5673 (g)	3/19	24	26,640	25.9 ± 1.8	118.08 ± 6.45		4.56 ± 0.40
5674 (g)	3/21	24	21,600	16.6 ± 1.6	81.28 ± 6.30		5.08 ± 0.52
5878 (g)	3/22	24	21,600	27.2 ± 1.4	140		5.13
5879 (g)	3/25	24	24,500	3.2 ± 0.8	12.05		3.76
5880 (p)	3/28	24	21,600	1.6 ± 0.7	13.4		2.97
5881 (g)	3/28	24	23,000	3.9 ± 0.8	8.01		2.05
5877 (p)	4/2	24	10,400	≤ 0.84	7.38		
5882 (p)	4/5	24	25,000	11.9 ± 1.1	52.9		4.44
5883 (p)	4/9	24	31,000	12.1 ± 1.2	46.5		3.84
5884 (p)	4/11	24	17,300	7.3 ± 0.9	22.4		3.07
6308	5/23	24	18,000	3.9 ± 1.2	15.5 ± 2.7	9/10	4.0 ± 1.5
6309	5/28	24	24,000	12.3 ± 2.1	11.1 ± 3.8	9/10	0.9 ± 0.4
6310	5/31	24	23,000	11.6 ± 1.9	46.2 ± 4.1	9/10	4.0 ± 3.8
6311	6/5/	24.66	25,000	≤ 0.94	≤ 1.79	9/10	
6312	6/7	24.16	25,000	2.3 ± 1.0	11.0 ± 2.3	9/10	4.9 ± 2.4
6313	6/12	24	24,000	4.4 ± 1.3	26.1 ± 2.5	9/10	5.9 ± 5.3
6314	6/18	23.66	24,000	6.4 ± 1.3	39.9 ± 1.4	9/10	6.3 ± 1.3
Mt. Haleakala (10,000 ft)							
6668	4/16	24	23,000	13.1 ± 2.4	20.0 ± 4.0	10/28	1.53 ± 0.4
6669	6/28	24	34,500	8.4 ± 4.6	85.0 ± 10.9	10/28	10.0 ± 5.6
6670	6/29	24	8,600	1.8 ± 6.4	22.8 ± 5.3	10/28	12.8 ± 26
6671	7/2	24	17,200	4.1 ± 2.3	14.3 ± 3.5	10/28	3.5 ± 2.1
6672	7/4	24	21,600	4.3 ± 3.5	16.5 ± 5.0	10/28	3.8 ± 3.3
6673	7/10	24	28,800	15.1 ± 2.2	71.5 ± 4.1	10/28	4.7 ± 0.7
6674	7/10	24	26,500	22.2 ± 13.2	59.5 ± 20	10/28	2.7 ± 1.0
6675	7/12	24	26,000	10.0 ± 3.6	66.1 ± 7.6	10/28	6.6 ± 0.2
6676	7/16	24	30,000	26.0 ± 7.6	352 ± 18	10/28	13.7 ± 3.8
6677	7/18	24	43,000	17.9 ± 2.2	528 ± 9	10/28	29.5 ± 3.0
6678	7/24	12	11,000	14.0 ± 2.9	171 ± 7	10/28	12.2 ± 2.5
Haleakala							
6959	9/20	23h 55m	18,480	2.3 ± 1.1	61.8 ± 3.8		27.5 ± 13
6956	9/4	27h	19,440	2.8 ± 0.8	16.3 ± 2.4		5.6 ± 1.7
6954	8/28	30h	30,600	≤ 0.71	7.6 ± 3.9		≤ 70
6953	8/24	24h 30m	9,555	≤ 0.90	1.5 ± 1.2		≤ 6.6

Table 66 (Continued)

HASL No.	Date, 1957	Sample time, hr	Volume, cu ft	Sr ⁹⁰ , dis/min/sample	Sr ⁸⁹ , dis/min/sample	C date	Sr ⁸⁹ /Sr ⁹⁰ ratio
Mauna Loa							
6958	9/9	24h 15m	36,740	1.9 ± 0.7	12.8 ± 2.1		6.7 ± 3.1
6957	9/4	24h 10m	40,600	2.1 ± 0.9	2.5 ± 2.3		1.2 ± 1.2
6955	8/30	22h 50m	36,300	≤ 0.75	6.7 ± 2.2		9.5 ± 10.4
6744	7/10	17	26,500	4.0 ± 0.9	24.0 ± 1.8		6 ± 1.4
6745	8/20	24h 10m	49,000	5.3 ± 1.1	45.2 ± 3.5		8.5 ± 1.9
6746	8/21	24h	49,000	4.5 ± 1.2	25.8 ± 3.5		5.7 ± 1.6
* * * * *							
Mauna Loa (11,000 ft)							
6744*	7/10	17	26,500	4.0 ± 0.9	24.0 ± 1.8	12/26/57	6 ± 1.4
6745†	8/20	23.5	49,000	5.3 ± 1.1	45.2 ± 3.5	12/26/57	8.5 ± 1.9
6746†	8/21	24	49,000	4.5 ± 1.2	25.8 ± 3.5	12/26/57	5.7 ± 1.6
6955	8/30	22.83	36,300	≤ 0.75	6.7 ± 2.2	12/26/57	
6957	9/4	24.17	40,600	2.1 ± 0.9	2.5 ± 2.3	12/26/57	0.84 ± 1.2
6958	9/9	24.25	36,740	1.9 ± 0.7	12.8 ± 2.1	12/26/57	6.7 ± 3.1
7103*	9/30	12	10,000	14.4 ± 3.1	≤ 0.76	2/27/58	
7105*	10/11	23.5	16,000	≤ 0.50	3.04 ± 2.70	2/27/58	
7107*	10/18	21	19,000	5.78 ± 1.80	5.03 ± 3.22	2/27/58	0.87 ± 0.62
7429	10/27	24	21,600	1.61 ± 1.40	9.24 ± 2.70	2/27/58	5.75 ± 5.18
7430	11/3	24	20,450	≤ 0.46	16.71 ± 2.49	2/27/58	
7432	11/11	24	18,720	1.67 ± 1.10	9.23 ± 2.23	2/27/58	5.54 ± 3.05
Haleakala (10,000 ft)							
6953	8/24	24.5	9,555	≤ 0.90	1.55 ± 1.2	12/26/57	
6954	8/28	30	30,600	≤ 0.71	7.6 ± 3.9	12/26/57	
6956	9/4	27	19,440	2.8 ± 0.8	16.3 ± 2.4	12/26/57	5.6 ± 1.7
6959	9/20	23.9	18,480	2.3 ± 1.1	61.8 ± 3.8	12/26/57	27.5 ± 13
7104	10/3	25.5	28,500	3.8 ± 2.0	≤ 0.58	2/27/58	
7106	10/11	24.25	19,000	≤ 0.42	14.1 ± 2.90	2/27/58	
7431	11/8	24	14,450	2.55 ± 1.40	≤ 0.70	2/27/58	

* Flow through one-half filter.

† Total flow sample, one-half filter.

Table 67—FALLOUT ANALYSIS OF RAIN GAUGE COLLECTIONS
(United States Weather Bureau, Project "Charlie")

HASL No.	Collection dates, 1957	Total β Activity						Total Sr ⁹⁰ , mc/sq mile
		HCl soluble		HCl insoluble		Total Sr ⁸⁹		
		mc/sq mile	C date	mc/sq mile	C date	mc/sq mile	C date	
7053	9/9-9/16	12.6 ± 1.3	12/4/57	0.22 ± 0.11	12/22/57	4.26 ± 0.68	12/22/57	0.136 ± 0.009
7054	9/16-9/30	10.3 ± 1.1	12/4/57	0.45 ± 0.11	12/22/57	1.66 ± 0.18	12/23/57	0.134 ± 0.018
7115	9/30-10/8	≤ 2.2	1/3/58	≤ 0.22	1/17/58	0.76 ± 0.11	1/31/58	0.067 ± 0.011
7116	10/8-10/14	≤ 2.2	1/7/58	0.31 ± 0.11	1/14/58	0.34 ± 0.07	1/31/58	0.016 ± 0.009
7117	10/14-10/21	≤ 2.2	1/3/58	≤ 0.22	1/17/58	0.11 ± 0.04	2/6/58	≤ 0.011
7118	Rinse water used during October col- lections	≤ 2.2	1/6/58	0.40 ± 0.11	1/23/58	≤ 0.11	1/31/58	≤ 0.027
7250	10/22-11/11	51.6 ± 6.7	1/11/58	3.4 ± 0.7	1/21/58	0.63 ± 0.18	2/12/58	0.058 ± 0.018

7. VARIABILITY OF Sr⁹⁰ IN MILK

Monitoring of selected milk supplies indicates the seasonal variability and time trends for Sr⁹⁰ in milk. In addition, it is desirable to know something of the local variability independent of these time and seasonal changes. Three studies are reported here which are related to these problems.

7.1 NEW YORK STATE DEPARTMENT OF HEALTH MILK POWDERING PLANT SURVEY

From the end of June 1957 through the end of August 1957, the New York State Department of Health collected three series of powdered milk samples at nine milk powdering plants in New York State. These samples were analyzed at HASL for Sr⁸⁹ and Sr⁹⁰, and each value reported is the average of replicate analyses. The error term is one standard deviation from the mean. The data are presented in Table 68, and the sampling locations are indicated on Fig. 15.

The variable Sr⁸⁹/Sr⁹⁰ ratio may reflect the fallout from the Plumbbob tests in Nevada conducted during this time, but the Sr⁹⁰ figures are reasonably consistent at a given site. Although differences can be seen from one location to another, they are not large and probably reflect variable grazing conditions rather than differences in the amount of fallout. A relatively small range of Sr⁹⁰ values, such as shown here for New York State milk, is expected in an area where weather conditions do not vary markedly.

7.2 VARIABILITY OF Sr⁹⁰ IN POWDERED MILK DURING A ONE-DAY SPRAY-DRYING OPERATION AT COLUMBUS, WISC.

On Nov. 16, 1956, Dr. L. T. Alexander visited the Borden Company's milk powdering plant at Columbus, Wisc., to collect samples during a one-day spray-drying operation. A special run was conducted over a 15-hr period. Samples were taken at about 2-hr intervals. This was a production run, and the milk entering the processing equipment was not from a single large batch but represented several tank changes during the series. Since processing consumes about one tank per hour and one tank represents the largest blend made, the test should indicate the variability that might be expected in Sr⁹⁰ for a normal run. This variability is extremely important because our normal sampling is a 5-lb can selected weekly. The results of analyses for this one-day processing period range from 3.5 to 5.5 $\mu\text{c/g}$ of cesium. This relatively large variation must be taken into account when observing trends in the milk results for any geographical location as a factor of time.

7.3 VARIABILITY OF Sr⁹⁰ IN MILK COLLECTED AT SIX WISCONSIN FARMS

Dr. Lyle T. Alexander of the Department of Agriculture collected milk from six Wisconsin farms on the same day. These farms were selected to contrast the source of drinking water for cattle, particularly as related to cesium content of the milk. The cesium data are not yet available, but the strontium concentrations in the milk do indicate a possible lowering of milk concentration when well water is the source for the cattle.

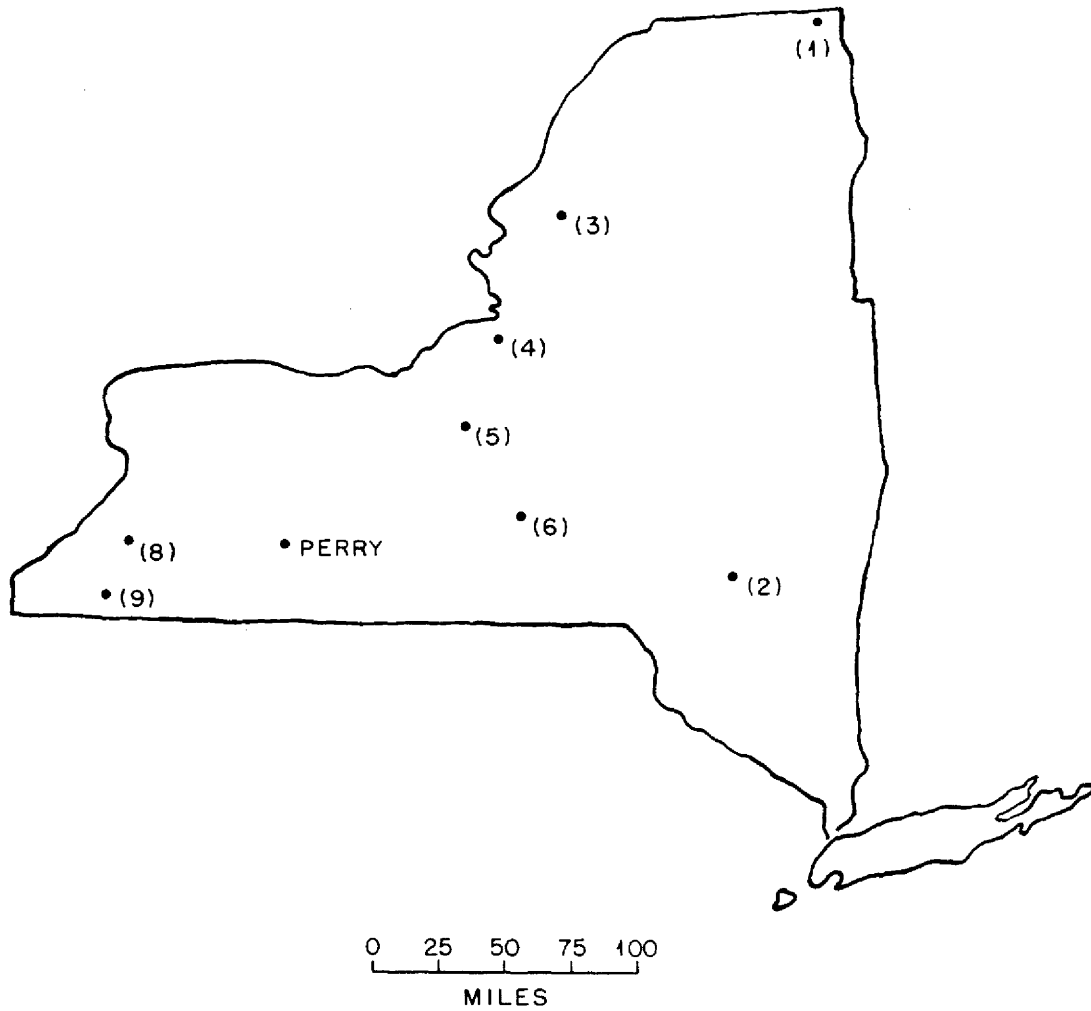

Fig. 15—New York State Department of Health milk powdering plant survey. (1), Champlain Milk Products, Champlain; (2) Andes Co-op Creamery, Andes; (3), Borens, Evans Mills; (4), Ontario Milk Producers Co-op, Mexico; (5) Cooperdale Dairy, Inc., Skaneateles; (6) Borens Farm Products, Cincinnatus; (7). Arkport Dairies, Arkport; (8), Collins Center Cooperative, Collins Center; (9). Queensboro Milk Products Co., Steamburg.

Table 68 — MILK POWDERING PLANT SURVEY FOR Sr⁹⁰ IN POWDERED MILK
(New York State Department of Health)

	HASL No.	Sampling date, 1957	Ca in ash, %	Sr ⁸⁹ /Sr ⁹⁰ *†	Sr ⁹⁰ , † μc/g Ca
Arkport Dairies, Arkport‡	6450	6/28	15.0	5.7 ± 1.1	4.13 ± 0.09
	6820	7/6	15.4	7.5 ± 1.5	4.14 ± 0.08
Collins Center Cooperative, Collins Center	6455	6/28	14.1	5.8 ± 0.8	6.25 ± 0.60
	6896	8/31	15.8	7.9 ± 0.2	4.33 ± 0.52
Queensboro Milk Products Co., Steamburg	6454	6/2	15.1	15.5 ± 1.3	7.74 ± 0.26
	6826	8/1	14.8	8.6 ± 0.2	7.51 ± 0.24
	6891	8/29	13.7	9.1 ± 1.7	5.89 ± 0.50
Cooperdale Dairy, Inc., Skaneateles Junction	6447	6/24	15.6	5.7 ± 1.7	4.07 ± 0.60
	6819	7/28	13.7	16.7 ± 0.2	4.45 ± 0.15
Ontario Milk Producers Coop., Mexico	6449	Early in June	14.2	5.5 ± 0.1	5.26 ± 0.78
	6448	6/24	15.1	3.4 ± 1.0	5.17 ± 0.78
	6822	7/27	14.1	14.8 ± 0.2	5.65 ± 0.14
	6890	8/28	16.6	8.9 ± 0.9	4.22 ± 0.42
Bordens Farm Products, Cincinnati	6452	6/28	14.7	4.7 ± 0.6	5.24 ± 0.40
	6825	7/31	15.0	11.2 ± 1.4	5.81 ± 0.16
	6893	8/30	15.4	14.2 ± 1.1	6.57 ± 0.13
Andes Coop Creamery, Andes	6451	6/28	14.5	5.3 ± 1.0	7.57 ± 0.17
	6821	7/22	14.5	9.7 ± 1.4	8.79 ± 0.47
	6895§	8/21	14.0	11.7 ± 1.0	6.52 ± 0.39
Champlain Milk Products, Champlain	6453	6/30	14.4	8.4 ± 2.4	5.26 ± 0.31
	6823	7/29	15.0	10.8 ± 0.6	6.38 ± 1.23
	6894	8/30	16.2	12.8 ± 0.7	5.08 ± 0.38
Bordens, Evans Mills	6824	7/30	14.6	25.4 ± 3.2	6.18 ± 0.59
	6892	8/29	14.7	10.1 ± 0.4	4.52 ± 0.03

*Extrapolated to sampling date.

†Error term is one standard deviation from the average of three determinations.

‡Discontinued for summer months.

§Labeled as Delaware Co. Farmers Coop at Delhi; also Rock Royal Coop.

Table 69—VARIABILITY OF Sr⁹⁰ IN POWDERED MILK DURING A ONE-DAY SPRAY-DRYING OPERATION

(Sampling date, 11/19/56; Location, Borden, Co., Columbus, Wisc.)

Time	Sr ⁹⁰ /g Ca, $\mu\mu\text{c}$
Start	4.5
End of 1st hr: 8:35 am	4.7
End of 2nd hr: 9:35 am	4.4
End of 4th hr: 11:35 am	3.5
End of 6th hr: 1:35 pm	3.4
End of 8th hr: 3:35 pm	3.8
End of 10th hr: 5:35 pm	4.3
End of 12th hr: 7:35 pm	4.2
End of 14th hr: 9:35 pm	5.5
End of run: 11:15 pm	5.1

Table 70—VARIABILITY OF Sr⁹⁰ IN MILK COLLECTED AT SIX WISCONSIN FARMS ON THE SAME DAY, AUGUST 1957

Farm	Location	Water source	Sr ⁹⁰ /g Ca, $\mu\mu\text{c}$
Eagan	Columbia Co., Wisc.	River	6.77 ± 0.25
Morrow	Columbia Co., Wisc.	River	4.76 ± 0.72
Ramsay	Columbia Co., Wisc.	Pond	4.89 ± 0.28
Allen	Columbia Co., Wisc.	Pond	5.77 ± 0.04
Premo	Columbia Co., Wisc.	Well	2.95 ± 0.44
Lewke	Dane Co., Wisc.	Well	3.78 ± 0.14

Part 3

BIBLIOGRAPHIES

THIS PAGE

WAS

INTENTIONALLY

LEFT BLANK

IN

ORIGINAL

THIS PAGE

WAS

INTENTIONALLY

LEFT BLANK

IN

ORIGINAL

ANNOTATED BIBLIOGRAPHY ON LONG-RANGE EFFECTS OF FALLOUT FROM NUCLEAR EXPLOSIONS*

(Papers published since the Congressional Hearings of 1957)

Allen G. Hoard

New York Operations Office, Atomic Energy Commission

1. Alba, A. Fernando, Beltran, Virgilio, Brody, T. A., Lezama, Hugh, Moreno, A., Tejera, M. A., and Vazquer, B. PRELIMINARY INFORMATION ON STUDIES OF RADIOACTIVE RAIN. *Revista mexicana de fisica* 5, 153-66 (1956).
Data on radioactive rain, which were obtained by the gummed leaf method and by collection in a free surface of water are presented. The experimental methods are described. Some conclusions are obtained on the relative efficiency of the two methods and their relations to atmospheric precipitation.
2. Allen, J. S. A-BOMB FALLOUT IN NORTHERN WEST VIRGINIA. *West Virginia University Bulletin*, Series 56, 55-57 (1957).
3. Anderson, Ernest C., Schuch, Robert L., Fisher, William R., and Langham, W. RADIOACTIVITY OF PEOPLE AND FOODS. *Science* 125, 1273-78 (1957).
Measurements of the Cs^{137} content of people and of foodstuffs indicate that this nuclide is unlikely to be a decisive factor in the long-term hazards from weapons testing and reactor waste disposal. The amount of Cs^{137} now present in the population of the United States averages 0.006 microcurie and shows no marked dependence on geographic location. The average radiation dose received from Cs^{137} is one-twentieth of that received from natural radiopotassium and 1 per cent of the average total dose from all natural sources. Because of the short biological half life of cesium of about 140 days, it does not accumulate in the body as does Sr^{90} . The study of the distribution of Cs^{137} is being continued to furnish information on the mechanisms of the fallout process and provide a measure of the rate of fallout and of stratospheric storage.
4. Armagnac, Alden P. WILL BOMB DUST ENDANGER YOUR HEALTH? *Popular Science* 170, 163-67, 256, 258, and 260 (1957).
5. ATOMIC ENERGY IN ITS REPERCUSSIONS ON LIFE AND HEALTH. Papers from a Scientific Conference held at the National Museum of Natural History, July 1-2, 1955. Paris, L'Expansion Editeur, 254 p. (1956) (in French).
The papers given at the July 1955 conference in Paris on the dangers of atomic energy and radiation are presented. Topics discussed include the dangers inherent in atomic

*This report has also been issued as AEC report NYO-4753 (Supplement 2).

equipment; the radioactive effects of atomic explosions; a review of the analyses made in Japan of the radioactive ash from the March 1954 Bikini explosions; long distance propagation and characteristics of the radioactive particles emitted in atomic explosions; eventual influences of atomic explosions on evolution; radioactivity in air and rain; radioactive clouds; meteorological effects of atomic explosions; a general review of the biological effects of ionizing radiation; medical problems posed by the immediate effects of atomic explosions; cataracts received from explosions or research in atomic energy; atomic radiation and aquatic life; biological danger from powders emitting beta rays; effect of weak doses of radiation; ionizing radiation and the gases in atomic industry; and therapy for radiolesions.

6. Auerback, C. BIOLOGICAL HAZARDS OF NUCLEAR AND OTHER RADIATIONS. *Nature* 178, 453-54 (1956).

A comparison of authoritative digests by Great Britain and the United States was discussed. Both reports show that the present dangers arise much more from excessive use of x-rays than from bomb fallout or from atomic energy establishments.

7. Blifford, I. H., Friedman, H., Lockhart, L. B., and Baus, R. A. GEOGRAPHICAL AND TIME DISTRIBUTION OF RADIOACTIVITY IN THE AIR. *Journal of Atmospheric and Terrestrial Physics* 9, 1-17 (1956).

A report on the results of continuous measurements on both natural and fission product radioactivity of the air at ground level over a 5-year period beginning in 1950.

8. Blifford, I. H., Friedman, H., Lockhart, L. B., and Baus, R. A. RADIOACTIVITY OF THE AIR. Naval Research Laboratory Report No. 4760. Office of Technical Services, Washington 25, D. C. Report No. PB121222.

Since 1949 the Naval Research Laboratory has operated stations for the detection and collection of atmospheric radioactivity. This report presents an analysis of some of the results obtained. The concentrations in curies/cc of fission products in the air at ground level from early 1951 through late 1954 is given in graphical form for a number of locations in various parts of the world. Maximum activities of the order of 10^{-16} curie/cc were recorded after atomic explosions. It is apparent that the distribution of activity throughout the earth's atmosphere is not uniform. Correlations which have been made with both low and high level wind trajectories, seem to show that the clouds of fission activity follow fairly restricted paths. In considering the distribution of fission products from atomic explosions, it will not be valid to assume a uniform distribution in the total atmosphere of even one hemisphere.

9. Blifford, I. H. and Lockhart, L. B. RADIOACTIVITY OF THE AIR AND FALLOUT SAMPLES COLLECTED AT SITES ON THE 80th MERIDIAN DURING OCTOBER 1956. Naval Research Laboratory Problem A02-13, Project No. NR 612 130. 3p. (1956).

10. Boroughs, H. METHOD OF PREDICTING AMOUNT OF STRONTIUM-89 IN MARINE FISHES BY EXTERNAL MONITORING. *Science* 124, 1027-28 (1956).

11. British Atomic Scientists Association. STRONTIUM HAZARDS. *The Lancet* 878-9 (April 27, 1957).

12. Campbell, Charles I. RADIOSTRONTIUM FALLOUT FROM CONTINUING NUCLEAR TESTS. *Science* 124, 894 (1956).

Published data on the fallout of radiostrontium from nuclear tests are reviewed. Assuming a 10-year storage time and continuing test rate about twice that previously estimated, it is calculated that the Sr^{90} accumulated on the ground after about 35 years would be 80 cm/mi². This would correspond to about 0.14 MPC units in the soil.

13. Caster, W. O. STRONTIUM-90 HAZARDS. *Science* 125, 1291-92 (1957).

14. Chapman, N. G. and Humphrey, R. W. AN INVESTIGATION OF THE VARIATION OF THE ATMOSPHERIC RADIOACTIVITY AT WELLINGTON FROM 5 MAY TO 18 JULY 1955. *New Zealand Journal of Science and Technology*, Section B 37, No. 3, 396-406 (1955).

The collection apparatus was situated 9 m above the local ground level and 130 m above sea level. The filter paper collection method was used, a description of the apparatus used

and a discussion of the efficiency of this method being included. In this discussion a lower limit for the average value of the radon content in the period of 37×10^{-18} curie/cm³ is obtained. A diurnal variation in the radon content was found which showed principal and secondary minima, the principal at about 12 to 14 hr N.Z.M.T. and the secondary at 20 to 21 hr N.Z.M.T. The effect of wind speed on the radioactive content is shown and some indications obtained regarding the influences of wind direction, barometric pressure, and rainfall. From the results, approximate upper limits for the amount of fission product activity present in relation to the amount of natural radioactivity in the atmosphere at this locality have been obtained.

15. Clayton, C. G. RADIOACTIVE CONTAMINATION OF FOODS FROM FALLOUT AS A SOURCE OF ERROR IN SOME ANIMAL EXPERIMENTS. *Nature* 179, 829-30 (1957).

Radioactivity in control animals since 1956 has increased so as to vitiate experiments. The activity of foods used was measured. The counts are given for rat cubes, milk, peas, sugar, flour, cabbage, carrot, cauliflower, salt, semolina, and water. The high count of the cabbage is probably from Cs¹³⁷ present at 4 micromicrocuries per gram.
16. Cockcroft, John. RADIOACTIVE POLLUTION FROM NUCLEAR EXPLOSIONS. *Smokeless Air* 25, 192-96 (Summer 1955).

Because it produces 100 to 1000 times more radioactive material than an atomic bomb, the hydrogen bomb is the most important source of radioactive material. If a hydrogen bomb is exploded on the ground millions of tons of soil, ranging in size from 0.02 in diameter down to 0.001 inches, will be mixed with the radioactive products, the larger particles settling near the scene of the blast, and the remainder dispersing in the stratosphere—above 50,000 feet. In the case of an air burst practically all of the radioactivity will go into the stratosphere and from there be deposited uniformly. The author calculates that the contribution of radioactivity from weapons tests is small, considerably less than the radiation exposure received from natural sources of radioactivity, if the tests continue at the present level. However, in the case of a full-scale hydrogen bomb war, the hemisphere contamination would correspond to a dose of about 25 r which could be damaging to future generations. Operation of nuclear plants for power, although sources of large amounts of radiation, can be controlled to minimize the radiation levels to the population. The major source of such contamination, radioactive wastes, can be handled through separation of the more hazardous strontium and cesium from the bulk of the wastes, storage of the residue for about 10 years followed by controlled release, and utilization of the separated cesium and strontium as by-product materials pending development of more satisfactory methods of handling and disposal.
17. Comar, C. L., Trum, Bernard F., Kuhn, U. S. G., Wasserman, R. H., Nold, M. M., and Schooley, J. C. THYROID RADIOACTIVITY AFTER NUCLEAR WEAPONS TESTS. *Science* 126, 16-19 (1957).
18. Cronkite, E. P., Bond, V. P., and Dunham, C. L. SOME EFFECTS OF IONIZING RADIATION ON HUMAN BEINGS. STUDY OF ACCIDENTAL DEPOSIT OF RADIOACTIVE MATERIAL ON INHABITED PACIFIC ISLANDS FOLLOWING DETONATION OF THERMONUCLEAR DEVICE. Washington, U. S. Government Printing Office. Catalogue No. Y3.At 7:22/TID-5338. 106p. \$1.25.

This report concerns the Marshallese and Americans accidentally exposed to radiation from fallout following the explosion of March 1, 1954, and includes a discussion of radiation injury in the human being. Radiation surveys of the areas revealed injurious radiation levels on inhabited atolls and evacuation was ordered immediately. The degree of radiation injury was assessed as quickly as possible, and appropriate care and study of the injured was instituted without delay. The initial data have been supplemented by field surveys 6 and 24 months after the original investigation. The results of this work are summarized.
19. Crosthwait, L. B. MEASUREMENT OF ATMOSPHERIC AND RADIOACTIVITY AT WELLINGTON. *New Zealand Journal of Science and Technology*, Section B 37, No. 3, 382-4 (1955).

A filter paper method of collecting atmospheric radioactivity is described. The mean radon concentration found by this method was 34×10^{-18} curie/cm³.

20. "DIRT" FROM "CLEAN" BOMBS. *Science News Letter* 72, 3 (1957).
21. Dubinin, N. P. PROBLEMS OF RADIATION GENETICS. *Vestnik Akademii Nauk S.S.S.R.* 26, No. 8, 22-3 (1956) (in Russian).

A general review is presented of recent experiments in genetics. Mutant and hereditary effects of the increase in natural radiation and that released by atomic and hydrogen tests were analyzed. Achievements and the possibilities of applying radiation in the induction of selective plant mutations are discussed.
22. THE EFFECTS OF NUCLEAR WEAPONS. Samuel Glasstone, ed. Washington, U.S. Government Printing Office, (1957), 587p. \$2.00.

The most recent data concerning the effects associated with explosions of nuclear weapons are presented. The data have been obtained from observations made of effects of nuclear bombing in Japan and tests carried out at the Eniwetok Proving Grounds and Nevada Test Site, as well as from experiments with conventional explosives, and mathematical calculations. The volume is intended for use in planning against possible nuclear attack.
23. Eisenbud, Merrill. GLOBAL DISTRIBUTION OF STRONTIUM-90 FROM NUCLEAR DETONATIONS. *Scientific Monthly* 84, No. 5, 237-44 (1957).

Presented at the Washington Academy of Sciences Fall Symposium, Washington, D.C., on November 15, 1956.
24. FALLOUT AND RADIATION HAZARDS EXPERTS DISAGREE. *Chemical and Engineering News* 35, 16-19 (June 24, 1957).

Over 30 experts in the fields of physics, biology, and genetics outlined what is known about radiation and its hazards and especially on the fallout problem before a special Subcommittee on Radiation of the Joint Committee on Atomic Energy. Expert opinion on the fallout problem is far from unified, but there seems to be accord on these points: (1) To date, accumulation of radioactivity from fallout has not been large; (2) A completely "clean" bomb causing no fallout, is apparently impossible; (3) Of the many radioactive materials released by nuclear explosions, strontium-90 is easily the most important; (4) Fallout is hazardous, to a degree, and some limitation on the injection of fission products into the atmosphere is desirable; and (5) It is not yet known how little radiation causes damages to man. Two points on which there is widest disagreement are uniformity of fallout throughout the world, and the biological effects of low level radiation to man. Various views on these points were presented. It is generally agreed that more research is needed on all these points.
25. FEWER TORNADOES IN AREAS OF THE ATOMIC CLOUDS. *U. S. News and World Report* 106 and 108 (April 29, 1955).
26. Garrigue, Hubert. RADIOACTIVITY OF AIR AND PRECIPITATIONS. *Comptes Rendus* 243, 584-85 (1956) (in French).

Since May 31, 1956, all the precipitations at the summit of the Puy-de-Dome, have been contaminated with artificial radioactive products. The flight survey of June 15 confirms these results.
27. Honda, M. A PROPOSED METHOD OF ANALYSIS OF RADIOACTIVE SUBSTANCES IN RAIN WATER. *Japan Analyst* 3, 368 (1954).

Ion exchange, using Amberlite IR-120 and Dowex 50 cation exchange resins, is proposed as a method of analysis of radioactive substances in rain water.
28. Hunter, C. G. RADIATION INJURIES IN ATOMIC WARFARE WITH STRESS ON FALLOUT. *Canadian Medical Association Journal* 76, 394-401 (1957).
29. Jacobs, Paul. CLOUDS FROM NEVADA; A SPECIAL REPORT ON THE AEC'S WEAPONS-TESTING PROGRAM. *The Reporter* 16, 10-29 (1957).
30. Kellogg, W. W., Rapp, R. R., and Greenfield, S. M. CLOSE-IN FALLOUT. *Journal of Meteorology* 14, 1-8 (1957).

The phenomenon of radioactive fallout from an atomic explosion is described, and a quantitative technique for determining the distribution of radioactive material on the ground is developed. The primary factors which must be considered are wind field, yield and height of burst, and particle-size distribution. Certain parameters which enter directly into a fallout determination are given quantitatively, such as the altitude and size of the atomic cloud (as a function of explosion yield and atmospheric stability) and particle fall-rates (as a function of altitude and particle size). Two hypothetical fallout patterns for a one-megaton explosion, computed on a high-speed digital computer are presented, showing the large effect which the wind has in determining the character of the fallout. The meteorological problems associated with a fallout prediction are discussed.

31. Kimura, Kenjiro. ANALYSIS OF RADIOACTIVE FALLOUT OF THE ATOMIC BOMB EXPLOSION ON BIKINI. *Radioisotopes (Japan)* 3, 1-4 (1954).

The radioactive fallout was found to contain 55.2, 7.0, 11.8, and 26.0% of CaO, MgO, CO₂, and H₂O, respectively, the chief constituent being Ca(OH)₂. The electric-spark method of analysis showed the presence of Al, Fe, and Si in addition to Ca and Mg. Its decay curve followed $I = ct^{-1.37}$, where I represents radioactivity, t, time since the explosion took place, March 1, 1954, and c, const. Its specific activity measured on April 23, 1954, was 0.37 mc/g. Radioactive nuclei identified by March 26 were Sr⁸⁹, Sr⁹⁰, Y⁹¹, Sr⁹⁵, Nb^{95m}, Nb⁹⁵, Ru¹⁰³, Rh¹⁰⁶, Te^{129m}, Te¹²⁹, Te¹³², I¹³¹, I¹³², Ba¹⁴⁰, Ce¹⁴¹, Ce¹⁴⁴, Pr¹⁴³, Pr¹⁴⁴, Nd¹⁴⁷, Pm¹⁴⁷, S³⁵, Ca⁴⁵, U²³⁷, and Pu²³⁹.

32. Kimura, Kenjiro. INTRODUCTION TO SPECIAL COLLECTION OF PAPERS. ANALYSIS OF THE BIKINI ASH. *Japan Analyst* 3, 333-34 (1955).

The incident of the Bikini ashes and the fishing boat is reported. Experiences on the boat are recorded, and fallout analyses are compared with those of Nagasaki and Hiroshima.

33. Kimura, Kenjiro, Ikeda, Nagao, Kimura, Kan, Kawanishi, H., and Kimura, M. RADIO-CHEMICAL ANALYSIS OF THE BODY OF THE LATE MR. *Radioisotopes (Japan)* 4, 22-7 (1956).

Analyses were carried out of various organs of Mr. [redacted] 200 days after he had exposed himself to radiation of the atomic bomb explosion on Bikini Atoll, March 1954. By ion-exchange chromatography, the presence of the following nuclides was indicated: Ce¹⁴⁴ and Pr¹⁴⁴ in the bone (I) (20×10^{-12} counts/g. fresh wt.). Liver (II), and Kidneys (III); Zr⁹⁵ and Nb⁹⁵ in II and III; Ru¹⁰⁶, Rh¹⁰⁶, Te^{129m}, and Te¹²⁹ in I, III, and muscles; and Sr⁸⁹, Sr⁹⁰, and Y⁹⁰ in I, II, and III. Activities found in these organs were decidedly higher than those found in the control samples obtained from individuals who died of other than the so-called radiation sickness. Radiation dose received by the bones of Mr. [redacted] was calculated to be approximately 8 rep.

34. Kulp, J. Laurence, Eckelmann, Walter R., and Schulert, Arthur R. STRONTIUM-90 IN MAN. *Science* 125, 219-225 (February 8, 1957).

The world-wide average strontium-90 content of man was about 0.12 micromicrocurie per gram of calcium (/10,000 of the maximum permissible concentration) in the fall of 1955. A few values as high as 10 times the average have been obtained. This value is in accord with the predicted value based on fallout measurements and fractionation through the soil-plant-milk-human chain. With the present burden of strontium-90, this average level should rise to 1 or 2 micromicrocuries of strontium-90 per gram of calcium.

35. Langham, Wright H., and Anderson, Ernest C. STRONTIUM-90 AND SKELETAL FORMATION. *Science* 126, 205-06 (1957).

36. Lapp, Ralph. INTERVIEW BY MIKE WALLACE. ABC Television Network, Sunday, June 9, 1957. 15p.

37. Lapp, Ralph. STRONTIUM LIMITS IN PEACE AND WAR. *Bulletin of the Atomic Scientists* 12, No. 8, 287-9 and 320 (1956).

38. Lapp, Ralph, Kulp, J. L., Eckelmann, W. R., and Schulert, A. R. STRONTIUM-90 IN MAN. *Science* 125, 993-34 (1957).

Biological hazards from fallout Sr⁹⁰ following nuclear explosions are discussed.

39. Lewis, E. B. LEUKEMIA AND IONIZING RADIATION. *Science* 125, 965-972 (1957).
40. Libby, Willard F. DEGREE OF HAZARD TO HUMANITY FROM RADIOACTIVE FALLOUT FROM NUCLEAR WEAPONS TESTS. (A letter from Dr. Libby to Dr. Schweitzer). *Bulletin of the Atomic Scientists* 12, 206-7 (1957).
41. Libby, Willard F. RADIOACTIVE FALLOUT.
Remarks prepared by Dr. Willard F. Libby, Commissioner, U. S. Atomic Energy Commission for delivery before the spring meeting of the American Physical Society, Washington, D. C., April 26, 1957.
42. Libby, Willard F. WHAT THE ATOM CAN DO TO YOU AND FOR YOU. *U. S. News and World Report* 64-70 and 73-77 (May 17, 1957).
43. Machta, L. and List, R. J. STRONTIUM-90 MAIN HAZARD. *Science News Letter* 71, 214 (1957).
44. Machta, L. and List, R. J. WORLD-WIDE TRAVEL OF ATOMIC DEBRIS. *Science* 124, 474-77 (1956).
The dispersal of radioactive airborne particles from two nuclear tests in the Pacific Proving Grounds of the AEC was traced by counting the activity on sheets of gummed film exposed at stations located throughout the world. A series of maps illustrate the fallout dispersal pattern at various times following the test shots. The effects of prevailing meteorological conditions on fallout dispersal and deposition are discussed.
45. METEOROLOGICAL ASPECTS OF ATOMIC RADIATION. *Science* 124, 105-12 (1956).
Bomb energy, detonation altitude, and atmospheric conditions have significant influences on the mechanism, rate, and pattern of fallout. These variables are discussed. Also considered is the possibility of an intolerable Kr^{85} concentration in the atmosphere from nuclear power plants.
46. Moloney, William C. LEUKEMIA IN SURVIVORS OF ATOMIC BOMBING. *New England Journal of Medicine* 253, 88-90 (1955).
47. Muller, Hermann J. AFTER EFFECTS OF NUCLEAR RADIATION. *National Safety News, American Society of Safety Engineers* 74, 42-8 (1956).
48. Nagasawa, Kakuma, Kawashiro, Iwao, Kawamura, Shoichi, Takenaka, Yusuki, and Nishizaki, Sasao. RADIOCHEMICAL STUDIES ON RADIOCONTAMINATED RICE CROPPED IN NIIGATA PREFECTURE IN 1954. *Bulletin of the National Hygienic Laboratory, Tokyo* No. 73, 187-90 (1955).
Radioactivity of various parts of rice seeds cropped in 1954 was determined and compared with that of 1953. Radioactivity due to K^{40} was established as total count of the ash and was subtracted for correction. None of the rice seeds in 1953 showed excess radioactivity. With the seeds in 1954 the following results were obtained: unhulled rice 3-6 cpm/g; chaff 3-6 cpm/2 g; unpolished rice 0-0.3 cpm/8 g; polished rice 0; rice bran 0. This radioactivity is thought to come from the rain, adherent to the chaff, but not from soil contamination.
49. Nagasawa, Kakuma, Kawashiro, Iwao, Kashima, Tetsu, Kawamura, Shiochi, Nishizaki, Sasao, and Matsushima, Takashi. STUDIES ON RADIOCONTAMINATION OF FOODSTUFFS EFFECTED BY A- OR H-BOMB EXPLOSION II. RADIOCONTAMINATION ON GREEN TEA. *Bulletin of the National Hygienic Laboratory, Tokyo* 31, No. 6, 201-3 (1956).
More radiation than those for natural K^{40} was found in 4 of 16 samples of green tea and another 3 samples sent from Professor Shiokawa who had found artificial radiation in them. The authors suggested the contamination of these samples was limited only to the surface, on which the radiocontaminated rain had dried up and not to the absorption of tea plants.
50. Nagasawa, Kakuma, Kawashiro, Iwao, Enomoto, Masayoshi, Matsushima, Takashi, and Kawamura, Shoichi. STUDIES OF RADIOCONTAMINATION OF FOODSTUFFS EFFECTED BY A- OR H-BOMB EXPLOSION. III. RADIATION OF MILK AND ITS PREPARATIONS.

Bulletin of the National Hygienic Laboratory, Tokyo, 31, 205-7 (1956).

No artificial radiation was found in any of 32 samples of milk of cows fed on the weeds which were supposed to have been contaminated with fission products in the rain. The researchers who reported finding artificial radiation in the milk in Japan appear to have mistaken natural K^{40} radiation for artificial radiation.

51. Nagasawa, Kakuma, Kawashiro, Iwao, Enomoto, Masayoshi, Kashima, Tetsu, and Matsushima, Takashi. STUDIES ON RADIOCONTAMINATION OF FOODSTUFFS EFFECTED BY A- OR H-BOMB EXPLOSION. IV. RADIOCONTAMINATION OF DRINKING WATER, VEGETABLES AND FRUITS IN JAPAN CAUSED BY H-BOMB EXPLOSIONS AT BIKINI ATOLL, 1954.

Bulletin of the National Hygienic Laboratory, Tokyo, 31, No. 6, 209-12 (1956).

The vegetables collected from various parts of Japan from May 19th to 30th, 1954 were considerably contaminated with radioactivity, though they were almost free from radiation after being washed. The dried and ash samples of some vegetables collected from August 30 to September 7, 1954 showed almost no artificial radiation. The radiation in rain water, tank water and well water collected from various parts of Japan from May to August 1954 were examined.

52. Nagasawa, Kakuma. STUDIES OF RADIOCONTAMINATION OF FOODSTUFFS AFFECTED BY A- OR H-BOMB EXPLOSIONS. V. RADIOCONTAMINATION OF SEA FISH AND ITS RADIOCHEMICAL ANALYSIS. *Bulletin of the National Hygienic Laboratory, Tokyo* 31, No. 6, 213-229 (1956).

53. Nagasawa, Kakuma, Nakayama, Goichi, Serizawa, Jun, and Nishizaki, Sasao. STUDIES ON RADIOCONTAMINATION OF FOODSTUFFS AFFECTED BY A- OR H-BOMB EXPLOSION. VI. ON THE EFFECT UPON LIVER OIL PRODUCTION BY THE USE OF RADIOCONTAMINATED FISH LIVERS AS A STARTING MATERIAL. *Bulletin of the National Hygienic Laboratory, Tokyo* 31, No. 6, 209-12 (1956).

The authors measured the radiation in each fraction in the process of liver oil production by the use of radiocontaminated liver as a starting material. In the result, almost no radioactivity was found in the liver oil; most of it was found in the residue and the waste. Therefore, it was easy to prepare liver oil from the liver with radiocontamination from A- or H-Bomb explosion experiments, 1954.

54. Nakano, Shoichi. STUDIES OF THE ANALYTICAL CHEMISTRY ON FILTER PAPER. XVI. PAPER CHROMATOGRAPHY OF RADIOACTIVE SUBSTANCE. RADIOCHEMICAL STUDIES ON "BIKINI ASHES." *Bulletin of the Chemical Society of Japan* 29, 219-24 (1956).

Radioactivity from "Bikini ashes" and U^{235} fission is divided into 3 major groups by ion-exchange methods and then subdivided by paper chromatography. In the first group, TeO_4^{-2} , SO_4^{-2} , PO_4^{-3} , and I^- , as well as two Ru^{106} spots are resolved in filter paper by iso-AmOH, Cs^{137} and Ce^{144} from the second and Y^{90} and Sr^{90} from the third group are separated also. It is shown that the presence of carrier or foreign elements alters the chromatographic behavior of the tracers.

55. Natanson, G. L. RADIOACTIVE AEROSOLS. *Uspekhi Khimii* 25, 1429-45 (1956) (in Russian).

Tabulations are given presenting various published data on safe atmospheric concentrations of various radioactive and nonradioactive aerosols. Methods of determination of active aerosol concentrations and dispersion as well as the technical applications of "labeled" aerosols are discussed. The effect of atomic explosions are analyzed considering the "nominal" atomic bomb based on U^{235} and Pu^{232} equivalent to 20,000 tons of TNT.

56. Pace, F. C. EFFECTS OF ATOMIC BOMB RADIATIONS ON HUMAN FOOD. *Canadian Journal of Public Health* 47, 113-141 (1956).

The increase in energy release of atomic weapons has increased the hazard of atomic radiation to food. Products of atomic explosions are probably similar regardless of size. Of the energy released, blast energy accounts for one-half, heat flash for one-third, initial nuclear radiation for one-twentieth, and residual radiation (potential fallout) about one-tenth. Radioactive elements may enter man by inhalation, by open wounds, or by ingestion

of contaminated food. Food can become contaminated by direct fallout on unprotected food or through metabolic assimilation by plants or animals. Dust-proof containers and undamaged cans provide protection from the first hazard. Cans, etc., should be washed before opening. Other food could be cleaned and used if subsequent monitoring indicated that the fallout material had been removed.

57. Patterson, R. L. and Blifford, I. H. ATMOSPHERIC CARBON-14. *Science* 126, 26-28 (1957).
58. Pinke, A. S. LIMITATION OF FISSIONABLE MATERIAL IN WEAPONS. *Bulletin of the Atomic Scientists* 13, 177-8 (1957).
59. Poling, James. BOMB-DUST RADIATION. *Better Homes and Gardens* 35, No. 5, 71, 172, 174, 179, and 182-3 (1957).
60. Russell, W. L. SHORTENING OF LIFE IN THE OFFSPRING OF MALE MICE EXPOSED TO NEUTRON RADIATION FROM AN ATOMIC BOMB. *National Academy of Sciences* 43, 324-329 (1957).
61. Romney, E. M., Neel, J. W., Nishita, H., Olafson, J. H., and Larson, K. H. PLANT UPTAKE OF Sr^{90} , Y^{91} , Ru^{106} , Cs^{137} , and Ce^{144} FROM SOILS. *Soil Science* 83, 369-376 (1957).
62. Saal, Herbert. WHAT IS THIS STRONTIUM 90 BUSINESS? *American Milk Review* 18, 30, 32, and 34 (1956).
63. Saiki, Masamichi. ON THE RADIOELEMENTS OF FISHES CONTAMINATED BY THE NUCLEAR BOMB TEST. *Japan Analyst* 7, No. 7, 443-9 (1957).
64. Sandor, Szalay and Denes, Berenyi. OBSERVATIONS OF UNUSUAL RADIOACTIVITY IN PRECIPITATIONS WHICH FELL IN BEBRECEN BETWEEN APRIL 22 - DECEMBER 31, 1952. *Magyar Tudományos Akademia, Budapest*, 13p. (1955) (in Hungarian).

It is suggested that radioactive fallout may be useful for the meteorological study of the movement of air masses, if an international organization records fission fragment concentration after atomic test explosions.
65. Schumann, G. ARTIFICIALLY RADIOACTIVE PRODUCTS IN THE ATMOSPHERE. *Zeitschrift für angewandte Physik* 8, 361-4 (1956).

The by-product activity arising from atom bomb test was investigated in Heidelberg by a filtration method during March 1953. The measurement of the activity on the filter was accomplished by a cylindrical beta-counter. The decay was proportional to $t^{-1}(1+x)$, where x is of the order of magnitude of 0.1, and thus approaches t^{-1} . The time of explosion can be determined by extrapolation of the reciprocal activity as a function of time.
66. Setter, L. R., Hagee, G. R., and Straub, C. P. ANALYSIS OF RADIOACTIVITY IN SURFACE WATERS. PRACTICAL LABORATORY METHODS. *American Society for Testing Materials Bulletin*, No. 227, 35-40 (1958).
67. Sievert, R. M., Gustafsson, S., and Sylander, C. G. INCREASE IN γ -RADIATION FROM POWDERED MILK AND BEEF. 1953-1956. *Nature* 178, 854-55 (1956).

Samples of powdered milk and beef preserved during the years 1953 to 1956 were examined for the presence of γ -radiation. The higher γ -radiation found in the last year was attributed to an increase in fission products. Data are compared with measurements on a series of children.
68. Smirnov, N. S. ON THE EFFECTS OF ATOMIC EXPLOSIONS ON THE CONDITIONS IN THE ATMOSPHERE. *Izvestiya Akademii Nauk S.S.S.R. Seriya Fizicheskaya*. 1227-31 (1956) (in Russian).

Effects of atomic bomb explosions on the increase in the atmospheric radioactivity and its influence on the weather has been reviewed.
69. Stanley, Charles W. and Kruger, Paul. DETERMINATION OF STRONTIUM 90 ACTIVITY IN WATER ION-EXCHANGE CONCENTRATION. *Nucleonics* 14, 114-18 (November 1956).

It appears that Sr^{90} can be used as a measure of the fission product contamination of water. A very sensitive method of water analysis of Sr^{90} - Y^{90} using ion exchange concen-

tration with selective elution of Y^{90} is described. Low-level techniques are employed to count the Y^{90} which reflects the concentration of Sr^{90} . Twenty-six liters of city tap water were concentrated and found to contain $3.10 + 0.21 \times 10^{-4}$ dpm/ml of Sr^{90} . If interfering activities are present, the Sr^{90} can be eluted and radiochemical separation performed.

70. Sugiura, Y. and Kanazawa, T. RADIOACTIVE FALLOUT COLLECTED IN TOKYO ON NOVEMBER 26, 1955. *Papers in Meteorology and Geophysics, Tokyo* 7, 128-35 (1956).
A large nuclear weapon test by Russia was reported November 23, 1955 as having occurred the previous day. Rain water and fallout samples taken in Tokyo produced a secondary fallout from some previous explosion. Rain water of the 21st and fallout of the 29th had radioactive content of 13 days half-life; fallout of the 26th, rain of the 27th 3 days half-life. Sample of the 26th consisted of 15 mg of sooty material giving nearly 2000 counts/min at that time.
71. Tajima, Eizo and Doke, Tadayoshi. RADIOACTIVE DUST IN THE OPEN AIR. *Kagaku (Tokyo) (Science)* 26, 124-9 (1956).
A review of radioactive dust.
72. Tanidazawa, M. and Ishihara, T. RADIOACTIVE ELEMENTS FOUND IN PLANTS CONTAMINATED BY RADIOACTIVE RAIN. *Radioisotopes (Japan)* 3, No. 1, 21-2 (1954).
Ashes obtained from contaminated trifolium repens, astragalus sinicus, and rumex japonicus were studied. The precipitate obtained by treating the acidic solution of the ash with H_2S followed by Fe^{+2} in the presence of NH_3 and NH_4Cl contained Y, Sr, and the rare earth elements.
73. Thomas, Harold Allen. THE PUBLIC HEALTH IMPLICATIONS OF RADIOACTIVE FALLOUT IN WATER SUPPLIES. *American Journal of Public Health and the Nation's Health* 46, 1266-74 (1956).
Significant increases in radioactivity in Massachusetts streams occurred only when precipitation took place through radioactive air masses. During the period from November 1951 to June 1953, there were 24 detonations, only five were followed by fallout extensive enough to raise the radioactivity above natural levels. The maximum observed in any sample was about 3×10^{-7} microcuries per milliliter of total beta activity at three days after fission.
74. Turekian, Karl and Kulp, J. Laurence. STRONTIUM CONTENT OF HUMAN BONES. *Science* 124, 405-7 (1956).
Marked regional differences in the Sr content of human bones were observed as a result of the analyses of 277 human bones from a world-wide sampling. The $\% Sr/\% Ca \times 10^3$ ratio was determined on bones ashed at 800° for 12-24 hours. This ratio was not affected by bone type, age, or sex. Bones from Brazil and Liberia had high average ratios, Denmark, Italy, and Japan, intermediate average ratios, and Cologne, Switzerland, and Bonn low average ratios (1.33, 1.25, 0.89, 0.71, 0.70, 0.36, 0.35, and 0.35, respectively). Analyses of bones of 9 other regions were also reported.
75. U. S. Department of Agriculture. RADIOACTIVE FALLOUT ON THE FARM. *Farmer's Bulletin No. 2107*. Washington, U. S. Government Printing Office, 1957. 16p. \$0.10.
76. U. S. Federal Civil Defense Administration. FALLOUT DEBRIS DEPOSITION. FCD 1.3: 11-31. Washington, U. S. Government Printing Office, (1957). \$0.25.
77. Warren, Shields. ANTI-PERSONNEL EFFECTS OF NUCLEAR WEAPONS. *Confluence* 5, No. 2, 131-8 (1956).
78. Weiss, Herbert V. and Shipman, W. H. BIOLOGICAL CONCENTRATION BY KILLER CLAMS OF COBALT-60 FROM RADIOACTIVE FALLOUT. *Science* 125, 695 (1957).
In 2 specimens of *Tridacna Gigas* recovered from the shores of Rongelap Island 2 years after the March 1954 nuclear detonation, readily detectable amounts of both beta- and gamma-radiation were present. The activity was attributable to Co^{60} (I) to the extent of 63 and 85% of the gross gamma-activity. As it is not a component of fission products, it is assumed that it was induced from an environmental precursor possibly Co^{59} , by the

neutron flux accompanying the detonation. It was not detected in samples collected one year after the detonation; this points to an enormous concentrating capacity of *Tridacna Gigas*.

79. World Federation of Scientific Workers. UNMEASURED HAZARDS. *London, World Federation of Scientific Workers*. 40p. (1956).
80. World Health Organization (United Nations). GENETIC EFFECTS OF RADIATION. Press Release, WHO/11, (March 13, 1957). 3p.
81. Yamada, Kinjiro, Tozawa, Harumi, Amano, Keishi, and Takase, Akira. STUDIES ON THE RADIOACTIVITY IN CERTAIN PELAGIC FISH. III. SEPARATION AND CONFIRMATION OF Zn^{65} IN THE MUSCLE TISSUE OF A SHIPJACK. *Bulletin of the Japanese Society of Scientific Fisheries* 20, No. 10, 921-26 (1955).

Ashed sample of the muscle tissue of shipjack, which were caught by "Shunkotsu-Maru" on June 19th near Bikini Atoll was used for the present study. Ion-exchanger method, using Dowex 50, was applied to separate radioactive elements with 0.2 N HCl, 0.5% oxalic acid and 5% ammonium citrate (pH 3.53, 4.18, 4.60, 5.02, 5.63, and 6.42) as the eluents. Elution curve of the ashed muscle is shown in Figure 1. Appreciable amounts of cationic radioactive elements were separated by 0.5% oxalic and by 5% ammonium citrate at the pH of 4.18 and also anionic radioactive elements were obtained by 0.2 N HCl. As the fraction, which can be withdrawn by ammonium citrate as pH 4.18, was proved the most active; further analysis was undertaken according to the scheme cited in Figures 2 and 5. In addition to this chemical separation, absorption curve of this specimen with tin foil was examined simultaneously (Figure 3) and thus the radioactive Zn^{65} was confirmed to be present in the fish muscle. Although it was difficult to detect radioactivity in rare-earth and alkaline-earth groups in the muscle tissue, attempts are being made for more precise examination.
82. Yamazaki, Fumio and Kakehi, K. ESTIMATE OF RADIATION DOSES RECEIVED BY THE INDIVIDUAL ABOARD A CONTAMINATED FISHING BOAT. *Radioisotopes (Japan)* 3, No. 1, 4-6 (1954).

A dose was estimated to be 120 r in 24 hours or 270 r in 13 days when calculated according to $t^{-1.2}$; or 240 r in 24 hours or 440 r in 13 days when calculated according to $t^{-1.4}$, observed value of decay, and supposing exposure to the radiation began 6 hours after the explosion had occurred on Bikini.
83. Yano, N. RADIOACTIVE DUST IN THE AIR. *Papers in Meteorology and Geophysics (Tokyo)* 7, No. 1, 34-41 (1956).

An electric precipitator is used to collect dust in the air because its collection efficiency for radioactive substances is up to 10 times that of the impactor of filter paper types. About 10 m^3 of air is filtered during 5 hours, and the trapped dust is measured more than 24 hours after collection to avoid the influences of naturally active substances. The average radioactivity of the air is approximately 10^{-16} curie/cc. During the period of observation 4 peaks occurred. The dates and maximum levels of artificial activity, respectively, are November 4-10, 1954, 1.2×10^{-7} $\mu\text{C/liter}$; April 11-13, 1955, 4.3×10^{-8} $\mu\text{C/liter}$; November 25-8, 1955, maximum unknown; and March 22-5, 1956, 1.0×10^{-7} $\mu\text{C/liter}$. The presumed dates and places of detonation corresponding to the peaks are October 31, 1954 northwest of Japan; March 29, 1955, Nevada, U.S.A.; November 22, 1955, near L. Baikal, U.S.S.R.; and March 13-15, 1956 unknown.
84. Yatazawa, Michihiko and Yamazaki, Yoshio. ABSORPTION OF FISSION PRODUCTS BY PLANTS (PART V) ABSORPTION OF GROSS FISSION PRODUCTS. *Soil and Plant Food (Tokyo)* 2, 158-163 (1956).
85. Yatazawa, Michihiko. RADIOACTIVE CONTAMINATION OF PLANTS IN JAPAN COVERED WITH RAIN-OUT FROM H-BOMB DETONATIONS IN MARCH-MAY 1954 AT BIKINI ATOLL, MARSHALL ISLAND. (PART II) RADIOACTIVE ELEMENTS OF CONTAMINATED PLANTS. *Soil and Plant Food (Tokyo)* 1, 23-4 (1955).

Following a fallout estimated at 0.2 micromicro/liter *Trifolium repens*, *Astragalus sinicus*, and *Rumex japonicus* were harvested and analyzed for radioactivity. Most of the

radioactivity (2300 – 4700 counts/min/50 g plant ash) was associated with oxalate precipitate. A small amount of activity in the Zn group is attributed to Zn^{65} produced by reaction $Zn^{64}(n,\gamma)$ from Zn employed in the mechanical parts of the bomb. Sr-Ba radioactivity was 0.1 that of the rare earth group. Distribution of the radioactive elements was nearly the same as that found on the No. 5 Fukuryu-Maru.

THIS PAGE
WAS
INTENTIONALLY
LEFT BLANK
IN
ORIGINAL

BIBLIOGRAPHY

MISCELLANEOUS PAPERS PUBLISHED SINCE THE CONGRESSIONAL HEARINGS OF 1957

1. *Bulletin of the Atomic Scientists*, 14, January 1958. Issue devoted to radiation, including fallout.
2. Commoner, Barry. The Fallout Problem. *Science*, 127, May 2, 1958. pp. 1023-1026.
3. Looney, W. B. Effect of Radium in Man. *Science*, 127, Mar. 21, 1958. pp. 630-633.
4. Machta, L. Discussion of Meteorological Factors and Fallout Distribution. Washington, U. S. Department of Commerce, Weather Bureau, Dec. 30, 1957, 11 pp. Paper presented before the American Association for the Advancement of Science, Indianapolis, Indiana.
5. Machta, L. and List, R. J. Meteorological Interpretation of Strontium 90 Fallout. Washington, U. S. Department of Commerce, Weather Bureau, May 1, 1958, 9 pp. Paper presented before the Washington Chapter, Federation of American Scientists.
6. Libby, W. F. Radioactive Fallout. Washington, U. S. Atomic Energy Commission, Mar. 27, 1958, 27 pp. Speech before the Swiss Academy of Medical Sciences, Lausanne.
7. Libby, W. F. Radioactive Fallout and Nuclear Test Suspension. Washington, U. S. Atomic Energy Commission, Apr. 30, 1958, 4 pp. Speech delivered at Amherst College, Amherst, Massachusetts.
8. Libby, W. F. Statement on Fallout in the Last Russian Test Series. Delivered before the Washington Chapter, Federation of American Scientists, May 1, 1958.
9. Libby, W. F. Carbon-14 from Bomb Tests. A statement delivered before the Washington Chapter, Federation of American Scientists, May 1, 1958.
10. Dunham, Charles L. The Biological Problems of the Atomic Age. Washington, U. S. Atomic Energy Commission, Nov. 20, 1957, 13 pp. Speech before the American Chemical Society, Newark, Delaware.
11. U. S. Atomic Energy Commission, Advisory Committee on Biology and Medicine. Statement on Radioactive Fallout. Washington, D. C., October 1957, 14 pp.
12. Dunlap, C. E. Delayed Effects of Ionizing Radiation. *Radiology*, 69, July 1957. pp. 12-17.
13. Crow, J. F. Genetic Considerations in Establishing Maximum Radiation Doses. *Radiology*, 69, July 1957. pp. 18-22.
14. Failla, G. Considerations Bearing on Permissible Accumulated Radiation Doses for Occupational Exposure. *Radiology*, 69, July 1957. pp. 23-29.
15. Russell, R. S. et al. Rate of Entry of Radioactive Strontium into Plants from Soil. *Nature*, 180, Aug. 17, 1957. pp. 322-324.

16. Nishita, H. et al. Summary of Certain Trends in Soil-Plant Relationship Studies of the Biological Availability of Fallout Debris. University of California Los Angeles (UCLA-401).
17. Hallden, N. A. et al. Methods of Calculating Infinity Gamma Dose from Beta Measurements on Gummed Film. U. S. Atomic Energy Commission, New York Operations Office (NYO-4859).
18. Hazards Associated with the Development of Weapons of Mass Destruction. *Nature*, 180, Aug. 24, 1957. pp. 358-360.
19. Neel, J. V. Special Problems Inherent in the Study of Human Genetics with Particular Reference to the Evaluation of Radiation Risks. *Proceedings of the National Academy of Sciences*, 43, August 1957. pp. 736-744.
20. Dobzhansky, T. Genetic Loads in Natural Populations. *Science*, 126, Aug. 2, 1957. pp. 191-194.
21. Zimmer, K. G. A Physicist's Comment on Some Recent Papers on Radiation Genetics. *Hereditas*, 43, 1957. pp. 201-210.
22. Newcombe, H. G. Magnitude of Biological Hazard from Strontium 90. *Science*, 126, Sept. 20, 1957. pp. 549-551.
23. Rafter, T. A. et al. Atom Bomb Effect—Recent Increase of Carbon-14 Content of the Atmosphere and Biosphere. *Science*, 126, Sept. 20, 1957. pp. 557-558.
24. Court Brown, W. M. et al. Radiation and Leukemia. *The Lancet*, 273, Aug. 24, 1957. pp. 389-390.
25. Auerbach, C. Genetic Hazards of Radiation. *Nature*, 180, Sept. 7, 1957. pp. 489-490.
26. Mole, R. H. Shortening of Life by Chronic Irradiation. The Experimental Facts. *Nature*, 180, Sept. 7, 1957. pp. 456-460.
27. Sprott, D. A. Probability Distribution Associated with Distinct Hits on Targets. *Bulletin of Mathematical Biophysics*, 19, September 1957. pp. 163-170.
28. Hawkins, M. B. The Engineering Approach to Radiological Contamination. *Mechanical Engineering*, 79, October 1957. pp. 920-921.
29. Davidson, Harold O. Biological Effects of Whole-Body Gamma Radiation on Human Beings. Baltimore, Johns Hopkins Press, 1957, 101 pp. (Published for the Operations Research Office).
30. Crow, James F. Effects of Radiation and Fallout. New York, Public Affairs Committee, Inc., 1957, 28 pp. (Public Affairs Pamphlet No. 256).
31. Lacey, W. J., and D. C. Lindsten. Removal of Radioactive Contamination from Water by Ion Exchange Slurry. *Industrial and Engineering Chemistry*, 49, October 1957. pp. 1725-1726.
32. Selove, W. Appraising Fallout. *New York Times*, Apr. 8, 1958. (Letter to newspaper).
33. Kulp, J. L. et al. Pauling Claim Challenged. *New York Times*, May 2, 1958. (Letter to newspaper).
34. Pauling, L. Genetic Menace of Tests. *New York Times*, May 16, 1958. (Letter to newspaper).
35. Rosenthal, H. L. Uptake of Calcium-45 and Strontium-90 from Water by Fresh-Water Fishes. *Science*, 126, Oct. 11, 1957. pp. 699-700.
36. Williams, L. G., and H. D. Swanson. Concentration of Cesium-137 by Algae. *Science*, 127, Jan. 24, 1958. pp. 187-188.
37. Glass, B. The Genetic Hazards of Nuclear Radiations. *Science*, 126, Aug. 9, 1957. pp. 241-246.

38. Comar, C. L., et al. Strontium-Calcium Movement from Soil to Man. *Science*, 126, Sept. 13, 1957. pp. 485-492.
39. Shipman, W. H. et al. Detection of Manganese-54 in Radioactive Fallout. *Science*, 126, Nov. 8, 1957. pp. 971-972.
40. Wasserman, R. H. et al. Dietary Calcium Levels and Retention of Radiostrontium in the Growing Rat. *Science*, 126, Dec. 6, 1957. pp. 1180-1182.
41. Anderson, E. C. et al. Barium-140 Radioactivity in Foods. *Science*, 127, Feb. 7, 1958. pp. 283-284.
42. Wald, N. Leukemia in Hiroshima City Atomic Bomb Survivors. *Science* 127, Mar. 28, 1958. pp. 699-700.
43. Boyd, J. et al. On the Mechanism of Skeletal Fixation of Strontium. Rochester, New York, University of Rochester (UR-512).
44. Radiation and Public Health (editorial). *Science*, 127, Apr. 4, 1958. pp. 727.
45. Adams, E. C., et al. The Compositions, Structures, and Origins of Radioactive Fallout Particles. San Francisco, U. S. Naval Radiological Defense Laboratory (USNRDL-TR-209).
46. Strauss, B. S. The Genetic Effects of Incorporated Radioisotopes: The Transmutation Problem. *Radiation Research*, 8, March 1958. pp. 234-247.
47. Low, K., and Bjornerstedt, R. Health Hazards from Fission Products and Fallout. I. Products of Instantaneous Fission of U-235 with Thermal Neutrons. *Arkiv für Fysik*, 13, No. 1, 1958. pp. 85-90.
48. Kulikova, V. G. Distribution of Ce-144 and Cs-137 in Pregnant and Lactating Mice: Their Entry into the Off-spring and Elimination in the Milk. *Doklady Akademii Nauk S.S.S.R.* (Biological Sciences Section Translation Edition), 114, May-June 1957. pp. 451-453.
49. Muller, H. J. Human Values in Relation to Evolution. *Science*, 127, Mar. 21, 1958. pp. 625-629.
50. Spear, F. G. On Some Biological Effects of Radiation. *British Journal of Radiology*, 31, March 1958. pp. 114-124.
51. Domshlak, M. P., et al. Evaluation of Small Radioactive Influences on the Human Organism. *Soviet Journal of Atomic Energy*, 3, No. 7, 1957. pp. 765-769.
52. Dunning, G. M. (Ed.) Radioactive Contamination of Certain Areas in the Pacific Ocean from Nuclear Tests. U. S. Atomic Energy Commission, U. S. Government Printing Office, Washington, 1957.
53. Glasstone, S. (Ed.) Effects of Nuclear Weapons. U. S. Atomic Energy Commission, Armed Forces Special Weapons Project, U. S. Government Printing Office, Washington, D. C., 1957.
54. House of Representatives, Congress of the U. S., Hearings before Subcommittee on Government Operations. Civil Defense for National Survival, Parts 1-7, U. S. Government Printing Office, Washington, D. C., 1956.
55. House of Representatives, Congress of the U. S., Twenty-fourth Intermediate Report of the Committee on Government Operations. Civil Defense for National Survival, U. S. Government Printing Office, Washington, D. C., 1956.
56. (Continuation of Hearings) New Civil Defense Legislation, U. S. Government Printing Office, Washington, D. C., 1957.
57. Japan Society for the Promotion of Science, Committee for Compilation of Report on Research in the Effects of Radioactivity. *Research in the Effects and Influences of the Nuclear Bomb Test Explosions*, I and II, Ueno, Japan, 1956 (in English).

58. Joint Committee on Atomic Energy, Congress of the U. S., Hearings before the Special Subcommittee on Radiation. The Nature of Radioactive Fallout and Its Effects on Man, Parts 1, 2, and 3 (Index). U. S. Government Printing Office, Washington, D. C., 1957.
59. Joint Committee on Atomic Energy, Congress of the U. S., Summary-Analyses of Hearings on the Nature of Radioactive Fallout and Its Effects on Man. U. S. Government Printing Office, Washington, D. C., August 1957.
60. U. S. Atomic Energy Commission, Semi-annual Report to Congress, U. S. Government Printing Office, Washington, D. C.

13th—January	1953	19th—December	1956
14th—July	1953	20th—July	1956
16th—July	1954	21st—January	1957
18th—July	1955		

61. Anderson, E. C., et al, Barium-140 Radioactivity in Foods, *Science*, 127, Feb. 7, 1958, p. 283.
62. Bond, V. P., et al, The Influence of Exposure Geometry on the Pattern of Radiation Dose, *Radiation Research*, 6, No. 5, May 1957, p. 554.
63. Comar, C. L., et al, Thyroid Radioactivity After Nuclear Weapons Tests, *Science*, 126, July 5, 1957, p. 16.
64. Comar, C. L., et al, Strontium-Calcium Movement from Soil to Man, *Science*, 126, Sept. 13, 1957, p. 485.
65. Eckelmann, W. R., et al, Strontium-90 in Man, II, *Science*, 127, Feb. 7, 1958, p. 266.
66. Glass, B., The Genetic Hazards of Nuclear Radiations, *Science*, 126, Aug. 9, 1957, p. 241.
67. Langham, W. H. and Anderson, E. C., Strontium-90 and Skeletal Formation, *Science*, 126, Aug. 2, 1957, p. 205.
68. Machta, L., et al, Airborne Measurements of Atomic Debris, *Journal of Meteorology*, 14, April 1957, p. 165.
69. Wasserman, R. H., et al, Dietary Calcium Levels and Retention of Radiostrontium in the Growing Rat, *Science*, 126, Dec. 6, 1957, p. 1180.
70. Williams, L. G. and Swanson, H. D., Concentration of Cesium-137 by Algae, *Science*, 127, Jan. 24, 1958, p. 187.
71. Schumann, G., Methodik der Messung künstlicher Radioaktivität in der Atmosphäre, *Beiträge zur Physik der Atmosphäre*, 30, pp. 189-99, 1958.
72. The Effects of Atomic Radiation on Oceanography and Fisheries, National Academy of Sciences—National Research Council, Washington, D. C., Publication No. 551.
73. Engström, A., et al, Bone and Radiostrontium, John Wiley and Sons, Inc., New York, 1957.
74. Robertson, J. S., Radiotoxicity of Internally Deposited Radioactive Material, Brookhaven National Laboratory, Report #3314.

BIBLIOGRAPHY OF DOCUMENTS SUBMITTED TO THE UNITED NATIONS SCIENTIFIC COMMITTEE ON THE EFFECTS OF ATOMIC RADIATION *

(Report A/AC.82/G/R.)

Argentina

- G/R.23 PRELIMINARY REPORT ON POSSIBLE METHODS OF ESTIMATING THE BIOLOGICAL EFFECTS OF SMALL DOSES OF RADIATION
Among biological effects of small doses of radiation, emphasizes especially: measurement of DNA synthesis using P³², C¹⁴, and P³⁵ radio-autography histochemical and electron microscopic examination of changes in lymphocytes and other components of peripheral blood.
- G/R.28 INFORMATION SUMMARY ON THE PRELIMINARY WORK CARRIED OUT IN ARGENTINA FOR THE MEASUREMENT AND STUDY OF RADIOACTIVE FALLOUT
Gives summary description of methods tried in Argentina for total fallout radioactivity.
- G/R.80 A GEOLOGICAL, RADIO-METRIC AND BOTANIC SURVEY OF THE REGION "LOS CHAÑORES" IN THE PROVINCE OF MENDOZA OF THE ARGENTINE REPUBLIC
Radiometric data on the above-mentioned region are shown on the attachment to the document.
- G/R.81 MEASUREMENTS OF THE COSMIC RAY EXTENSITY IN THREE LATITUDES OF THE ARGENTINE REPUBLIC
Data on the intensity of the Cosmic rays in 3 points of observation at different latitudes in Argentina.
- G/R.81
(Corr. 1) Correction to above report.
- G/R.82 ON THE ABSORPTION OF THE NUCLEONIC COMPONENT OF THE COSMIC RADIATION AT -15° GEOMAGNETIC LATITUDE
- G/R.83 MUTATIONS IN BARLEY SEEDS INDUCED BY ACUTE TREATMENTS BY GAMMA RAYS OF COBALT-60
A report of experiments on the induction of mutations at a number of loci in barley by irradiation of seeds with gamma rays of Co⁶⁰ at 10 r/min.
- G/R.83
(Add.1) Addendum to above report.

*A numerical cross reference of report numbers to countries is presented at the end of this Bibliography.

Argentina (Continued)

- G/R.84 **MUTATIONS IN BARLEY INDUCED BY FORMALDEHYDE**
A report of experiments on the induction of mutations at a number of loci in barley by formaldehyde.
- G/R.85 **SPONTANEOUS MUTATIONS IN BARLEY**
A report of experiments on spontaneous mutations at a number of loci in barley.
- G/R.86 **A STUDY OF RADIOACTIVE FALLOUT IN THE ARGENTINE REPUBLIC**
Describes the methods used in the Argentine Republic for fallout collection and measurement. Value for Sr⁹⁰ and total beta activity are given for the first two months of 1957.
- G/R.87 **A RESEARCH PROGRAMME IN THE ARGENTINE ON THE GENETIC INFLUENCE IN THE PLANTS OF THE IONIZING AND ULTRA-VIOLET RADIATION**
A brief summary of projected research in Argentina on the genetic effects of ionizing and ultra-violet irradiations of plants, comprising both surveys of areas of high natural background and a broad range of laboratory experiments.
- G/R.88 **PROGRAMME OF PHYSICAL OCEANOGRAPHY FOR THE INTERNATIONAL GEOPHYSICAL YEAR**
- G/R.89 **INFORMATION ON THE GENERAL PROGRAMME TO BE DEVELOPED IN THE ARGENTINE ON ITEMS OF INTEREST TO THE SCIENTIFIC COMMITTEE ON THE EFFECTS OF ATOMIC RADIATION**
A brief general survey of Argentina research activities related to the effects and levels of ionizing radiations.
- G/R.127 **CALCIUM AND POTASSIUM CONTENT OF FOODSTUFFS IN THE ARGENTINE REPUBLIC**
- G/R.154 **NORMAL CALCIUM CONTENT OF SAN JUAN WINES**
- G/R.157 **RADIOACTIVE FALLOUT FROM THE ATMOSPHERE IN THE ARGENTINE REPUBLIC DURING 1957**
Includes tables of results for first three-quarters of 1957. Total activity and Sr⁹⁰ content is measured.

Australia

- G/R.29 Report consisting of 6 parts, as follows:
(PART I) HUMAN GENETICS
Report gives recommendation as to the kind of human mutations which could be scored: several dominant autosomal genes should be investigated (gives list of such genetical abnormalities).
PART (II) PLANT GENETICS
Gives plan of research to be organized.
(PART III) RADIOBIOLOGICAL UNIT IN THE UNIVERSITY OF ADELAIDE
To be established.
(PART IV) NATURAL RADIATION BACKGROUND AND ENVIRONMENTAL CONTAMINATION
Describes future organization of investigations on natural radiation background and contamination; radioactivity of food will be determined.
(PART V) OCCUPATIONAL EXPOSURE IN AUSTRALIA
Describes monitoring system in application since 1940 and summarizes observations done by the use of film badges (gives statement of per cent of personnel having received a specified per cent of the permissible dosage).

Australia (Continued)

(PART VI) HEALTH AND SAFETY PRECAUTIONS IN URANIUM MINING AND MILLING IN AUSTRALIA

Describes health and safety precautions in uranium mining and milling.

Austria

G/R.19 INFORMATION PREPARED BY THE AUSTRIAN GOVERNMENT RELATING TO THE EFFECTS OF ATOMIC RADIATION

Describes radioactive warm springs at Bad Gastein, giving activity levels in water and air. Outlines wide scope of biological and instrumental research at Gastein Institute.

G/R.102 RADIOLOGICAL DATA. DEMOGRAPHIC DATA

Contains data on RBE dose rate in the gonad due to both natural and artificial sources. Demographic data of the whole population and of special groups are given.

Belgium

G/R.3 PRELIMINARY REPORT ON MODERN METHODS FOR THE EVALUATION OF THE BIOLOGICAL EFFECTS OF SMALL DOSES OF EXTERNAL RADIATION OR ABSORBED RADIOACTIVE MATERIALS

Concludes that the most hopeful measurements are those of: (1) DNases and cathepsins in plasma and urine; (2) DNA synthesis in vitro by bone marrow or biopsy specimens; (3) Platelet counts; (4) Antibody synthesis, and that the Committee should re-emphasize the need of appropriate fundamental research in radiobiology.

G/R.26 REPORT CONSISTING OF FIVE PARTS

1. Gives results of clinical observations of patients treated with X-rays, Ra or I^{131} and of persons occupationally exposed.

2. Gives results of studies relating to: the medical and physical control of persons occupationally exposed; the absorbing materials; and the radioactive contamination of the atmosphere.

3. Considers preventive or curative methods of syndromes of acute irradiation. States results of doses received by the occupationally exposed personnel of the *Institut du cancer* of Louvain, Belgium, and of hematological examinations of them.

4. Describes methods for measuring the radioactivity in rain and surface waters. Gives results of measures of radioactivity in rain waters.

5. Describes method for measuring the radioactivity of atmospheric dust by continuous filtering of air.

G/R.78 INFORMATION IN 8 PARTS ON HUMAN GENETICS SUBMITTED BY BELGIUM

Contains the Belgian memorandum on human genetics prepared for the Geneva meeting in April 1957 and a preliminary report on radioactive regions of Katanga (Belgian Congo). Besides this several reprints of Belgian contributions to radiobiology are presented. The topics included are: (1) Steroid metabolism in irradiated rat; (2) Endocrine response of irradiated animals studied by intraocular grafting; (3) Doses and hazards due to medical radiology; (4) Metabolism and toxicity of cystamine in the rat.

Part 1. Current uncertainties in the field of human genetics.

Part 2. A preliminary survey of vegetation and its radioactive content in the Katanga area.

Part 3. Influence of irradiation on the blood level of 17-hydroxycorticosteroids during the 24 hours following irradiation.

Belgium (Continued)

Part 4. Skin and depth doses during diagnostic X-ray procedures.

Part 5. General discussion of the need for methods of effective dose reduction in diagnostic X-ray procedures.

Parts 6 and 7. Chemical protection (a) metabolism of cystamine and (b) the effectiveness and toxicity of cystamine.

Part 8. Experiments on the ascorbic acid and cholesterol content of the suprarenals of the rat following irradiation of normal and hypophysectomised animals.

- G/R.116 REPORT ON HEALTH PROTECTION IN URANIUM MINING OPERATIONS IN KATANGA
- G/R.119 EFFECT OF A LETHAL DOSE OF RADIATION ON THE AMOUNT OF REDUCING STEROIDS IN THE BLOOD OF THE RAT
Indicates that lethal irradiation shows, in the blood, an increase of reducing steroids. This reaction presents a maximum which is not necessarily linked to the variations of the supra ascorbic acid and renal cholesterol.
- G/R.120 ACTION OF HYDROGEN PEROXIDE ON THE GROWTH OF YOUNG BARLEY PLANTS
The growth of coleoptiles of young barley plants treated with hydrogen peroxide is affected in the same way as when the plants are irradiated with X-rays.
- G/R.121 ACTION OF CYSTAMINE AND GLUTATHIONE ON X-RAY IRRADIATED BARLEY SEED
The cystamine and glutathione diminish the effects of X-rays on barley grains; mitosis are still possible after doses which would inhibit them in the absence of these agents.
- G/R.122 ACTION OF X-RAYS ON THE GROWTH OF INTERNODAL CELLS OF THE ALGA CHARA VULGARIS L.
Irradiation of internodal cells of *alga Chara Vulgaris L.* increases the elongation of these cells for doses up to 150 kr; above this dosage elongation is inhibited. c.f. G/R.156.
- G/R.155 RECENT RESEARCH ON THE CHEMICAL PROTECTORS AND PARTICULARLY ON CYSTEAMINE-CYSTAMINE
Discusses the possible mechanisms of action of chemical radioprotectors particularly of those above-mentioned.
- G/R.156 EFFECT OF X-RAYS ON THE GROWTH OF INTERNODAL CELLS OF THE ALGA CHARA VULGARIS L.
A complicated dose-effect relationship is shown when nondividing internodal cells are irradiated and their growth tested. c.f. G/R.122.
- G/R.158 THE ACTION OF VARIOUS DRUGS ON THE SUPRARENAL RESPONSE OF THE RAT TO TOTAL BODY X-IRRADIATION
Describes strict difference in action of radioprotectors (cysteamine) or narcotic drugs (morphine and barbiturate) in preventing adrenal changes of irradiated animals.
- G/R.159 NERVOUS CONTROL OF THE REACTION OF ANTERIOR HYPOPHYSIS TO X-IRRADIATION AS STUDIED IN GRAFTED AND NEWBORN RATS
Indicates that the changes of suprarenals after irradiation are consequence of a neuro-humoral chain reaction. The reaction of adrenals seems to have negligible importance in the pathogenesis of radiation disease.
- G/R.209 RADIOACTIVE FALLOUT MEASURED AT THE CEN DURING 1955-56 AND 57
Describes methods and results of fallout measurements in the period 1955-57.

Belgium (Continued)

- G/R.210 **AVERAGE DOSES RECEIVED BY THE PERSONNEL OF CEN FROM 1954-1957**
Summarizes the results of monitoring the professional exposure in nuclear energy education centre in Belgium. Film strips enables one to differentiate the exposure to beta, gamma, and neutron radiation. Only average doses of the personnel are given.

Brazil

- G/R.34 **ON THE INTENSITY LEVELS OF NATURAL RADIOACTIVITY IN CERTAIN
and
SELECTED AREAS OF BRAZIL**
G/R.34 States that Brazil has areas of intensive natural background where thorium
(Add.1) sands are present. Gives description of a survey on four sample areas which
were selected with regard to: (1) the geological structure and genesis of their
active deposits; (2) the extension, configuration and intensity of their radio-
metric levels; (3) the extent and variety of possible biological observations and
experiments.
- G/R.36 **MEASUREMENTS OF LONG-RANGE FALLOUT IN RIO DE JANEIRO**
Gives information on measurements of airborne activity in Rio de Janeiro,
including tables showing decay curves of activity of samples and concentration
of fission products in air during the period May-July 1956.
- G/R.38 **ABSORPTION CURVE OF FALLOUT PRODUCTS**
Is connected with G/R.36; gives absorption curve for fission product of an
airborne activity sample obtained by filtration.
- G/R.169 **ON THE NATURE OF LONG-RANGE FALLOUT**
Describes one surprising high value of daily collected fallout activity due to
a single big and highly active particle.
- G/R.169 Correction to above report.
(Corr.1)
- G/R.188 **SUMMARY-STRONTIUM-90 ANALYSIS IN DRY MILK AND HUMAN URINE**
- G/R.189 **ON THE COMPOSITION OF LONG-RANGE FALLOUT PARTICLES**
A single fallout particle of large dimensions and relatively high activity was
found by daily monitoring of fallout. A detailed investigation of the nature and
activity of this particle is presented.
- G/R.190 **ON THE UP-TAKE OF M_sTh 1 IN NATURALLY CONTAMINATED AREAS**
Gives preliminary results of an investigation on the uptake of natural radio-
isotopes by plants and animals in thorium-bearing area.

Canada

- G/R.9 **REPORT ON WASTE DISPOSAL SYSTEM AT THE CHALK RIVER PLANT OF
ATOMIC ENERGY OF CANADA LIMITED**
Describes procedures and results of ground dispersal of radioactive wastes
from a natural U heavy water-moderated reactor.
- G/R.10 **THE CANADIAN PROGRAMME FOR THE INVESTIGATION OF THE GENETIC
EFFECTS OF IONIZING RADIATION**
Describes a proposal to modify the system of recording of the national vital
statistics so as to render useful for genetic analysis the information contained
in certificates of births, marriages, and deaths (see also WHO WP 1).

Canada (Continued)

- G/R.12 **LEVELS OF STRONTIUM-90 IN CANADA**
Gives figures for Sr⁹⁰ and Sr⁸⁹ in milk powder at 7 stations, November 1955 – May 1956. The Sr⁹⁰ level averages 4.8 µc/g Ca. Cumulative total beta activity and calculated Sr⁹⁰ content of fallout analyzed by United States AEC from gummed papers, are summarized annually for 1953 to 1955. Independent Canadian measurements by methods which are not described differ from these by factors 2-5.
- G/R.98 **RADIOCHEMICAL PROCEDURES FOR STRONTIUM AND YTTRIUM**
A detailed ion exchange procedure is given for the determination of radiostrontium in different samples. Methods are described for the treatment of various organic materials.
- G/R.99 **LEVELS OF STRONTIUM-90 IN CANADA UP TO DECEMBER 1956**
Reports the results of radiochemical analysis for Sr⁹⁰ activity in milk and milk products and human bone. Natural strontium content determination in milk and bone are also reported.
- G/R.129 **DOSE FROM UNSEALED RADIO-NUCLIDES**
Calculations based upon information on shipments of radioisotopes show that the gonad dose to age 30 from unsealed radio-nuclides during 1956 in Canada is about 0.5% of the dose from the natural radiation sources. The main dose arises from I¹³¹.

China

- G/R.8 **REPORTS BY THE ATOMIC ENERGY COUNCIL OF THE EXECUTIVE YUAN OF THE REPUBLIC OF CHINA**
Briefly notes the radium content of certain Chinese and other waters and the occurrence of radioactive sailfish and dolphin in seas off Taiwan, June 1954.

Czechoslovak Republic

- G/R.17 **NATURAL RADIOACTIVITY OF WATER, AIR, AND SOIL IN THE CZECHOSLOVAK REPUBLIC**
Briefly draws attention to deviations from reciprocity and to the partial reversibility of many radiation induced phenomena, to the possible use of organisms in a state of abiosis as integral dose-indicators, to certain specially radiosensitive organisms and responses, and to questions of threshold. An extensive survey reviews many studies of natural radioactivity.

Denmark

- G/R.101 **MEASUREMENT OF ACTIVITY OF AIRBORNE DUST. MEASUREMENTS OF FALLOUT DEPOSITED ON THE GROUND**
Results of daily measured radioactivity in air (electrostatic filter method) and in precipitations (collection of rain water) in Copenhagen for the period 1956.

Egypt

- G/R.46 **PRELIMINARY REPORT ON ENVIRONMENTAL IODINE-131 MEASUREMENT IN SHEEP AND CATTLE THYROIDS IN CAIRO, EGYPT**
Contains measurement of radioactivity of I¹³¹ deposited in thyroids of sheep and cattle which were brought from all over Egypt, Sudan, and north coast of Libya. Sampling was made during the period from May to October 1956.

Federal Republic of Germany

- G/R.31 REPLIES TO THE QUESTIONS PUT BY THE UNITED NATIONS SCIENTIFIC COMMITTEE ON THE EFFECTS OF ATOMIC RADIATION
1. Levels of natural radiation background.
 2. Summarizes long-term research in biology and medicine under the direction of Langendorff (genetic effects); Rajewski (effects of natural radioactivity, accumulation of nuclides in tissues); Marquardt (research on natural mutation rates and their modification by irradiations); Other Institutes (pathological and physicochemical effect).
- No details given – refers to scientific publications.

Food and Agricultural Organization of the United Nations

- G/R.76 PRINCIPAL CALCIUM CONTRIBUTORS IN NATIONAL DIETS IN RELATION TO EFFECTS OF ATOMIC RADIATION FROM STRONTIUM 90
- Gives a general idea of foods contributing to the calcium uptake of human beings in various parts of the world in relation to the different food habits of these people. Data still quite preliminary.
- G/R.76 PRINCIPAL CALCIUM CONTRIBUTORS IN NATIONAL DIETS IN RELATION TO EFFECTS OF ATOMIC RADIATION FROM STRONTIUM 90
(Rev.1)
- G/R.165 GENERAL CONSIDERATION REGARDING CALCIUM AVAILABILITY IN THE BROAD SOIL GROUPS OF THE WORLD IN RELATION TO THE UPTAKE OF RADIOSTRONTIUM
- Classified soil groups with low calcium level. Recommends the investigations of the factors influencing Sr⁹⁰ uptake by plants growing on such soils.

France

- G/R.16 REPORT OF 3 PARTS
- The report includes three main parts:
1. Methods of measuring: the radioactivity produced by nuclear explosions and nuclear industry; natural or artificial radioactivity in living beings; the atmospheric radon.
 2. Reports on measurements relative to: natural radioactivity of rocks; radioactivity of soil and water; natural and artificial radioactivity of air, water and soil, occupational radiation exposure.
 3. Studies on genetic effects of radiations and on the descendants of patients treated with pelvic radiotherapy.
- G/R.179 ATOMIC ENERGY COMMISSION. CENTRE OF NUCLEAR STUDIES AT SACLAY, GIF-SUR-YVETTE (SEINE ET OISE), FRANCE. TECHNIQUES AND RESULTS OF MEASUREMENTS OF RADIOACTIVITY IN THE ENVIRONMENT. MEASUREMENT OF ENVIRONMENTAL ACTIVITY: METHODS AND RESULTS
- Gives results of measurements of both natural and artificial radioactivity in the environment.
- G/R.179 Correction to above report.
(Corr.1)
- G/R.180 BIOLOGICAL METHODS AVAILABLE FOR USE IN THE QUANTITATIVE DETECTION OF IONIZING RADIATION
- Surveys and evaluates the biological methods usable for the quantitative estimation of absorbed dose.
- G/R.186 DOSES RECEIVED BY THE GENITAL ORGANS OF CHILDREN DURING X-RAY EXAMINATIONS

France (Continued)

Suggests the improvement of the radiological techniques and certain protective measures for decreasing of gonad dose from radiography.

- G/R.194 GONAD DOSES IN RADIODIAGNOSIS
Summarizes the systematic study on the gonad dose due to diagnostic examination by means of X-rays.
- G/R.211 ETUDE DE LA DOSE GONADE, LORS DES EXAMENS RADIO-PHOTOGRAPHIQUES SYSTEMATIQUES. NOTE PRELIMINAIRE CONCERNANT EXCLUSIVEMENT L'IRRADIATION DES GONADES MALES.
Measurement of the gonad dose resulting in males from systematic standardized X-ray examination of the chest indicate that the exposure is very low. An average of 9 mrem for a period of 30 years is computed. The dose to the lungs is discussed with relation to the increase in frequency of lung cancer.
- G/R.212 DETERMINATION DU RAPPORT DOSE-ABSORBEE/DOSE D'EXPOSITION DANS L'OS ET LE MUSELE PAR LA METHODE DES GAZ EQUIVALENTS. PRINCIPE DE LA METHODS ET RESULTATS PRELIMINAIRES
Describes the method for determination of the dose absorbed in various tissues using ionization chambers filled with gas mixtures of equivalent density.
- G/R.213 LA RESTAURATION CONSECUTIVE A L'ACTION DES RADIATIONS IONISANTES
The authors first discuss the problem of recovery which they consider hypothetically. They attempt to show that it is a phenomenon which, though appearing very complex at first glance, can be simplified by relating the recovery to a definite effect.
They contribute a series of experiments showing that recovery is a very general phenomenon, common to all living things, and related to the metabolic activity of living matter.
They contribute a new method of experimental analysis which greatly facilitates interpretation of the results. They believe that the study of recovery should be developed on a much larger scale.

Hungary

- G/R.25 UNUSUAL RADIOACTIVITY OBSERVED IN THE ATMOSPHERIC PRECIPITATION IN DEBRECEN (HUNGARY) BETWEEN 22 APRIL-31 DECEMBER 1952
Describes methods and discusses results of measurements of total beta activity of fallout at Debrecen, April-December 1952.

India

- G/R.32 PROCEDURE USED IN INDIA FOR COLLECTION OF FALLOUT SAMPLES AND SOME DATA ON FALLOUT RECORDED IN 1956
Describes methods for measurements of airborne activity by filtration, and of deposited fallout with daily and monthly collection. The information includes tables giving results.
- G/R.33 EXTERNAL RADIATION DOSE RECEIVED BY THE INHABITANTS OF MONOZITE AREAS OF TRAVANCORE-COCHIN, INDIA
Contains results of a survey to measure the radiation level of the Indian state of Travancore. The radiation level due to gamma rays at about 3 feet above the ground level ranges from 6,000 to 100 mrad/year, approximately. The main contributors are thorium and its decay products.

India (Continued)

G/R.166 MEASUREMENTS ON THE RADIATION FIELDS IN THE MONAZITE AREAS OF KERALA IN INDIA

Presents results of measurements in the monazite area with high thorium content. As this area is one of the most densely populated areas in the world, the study of the relation between high level radiation background and eventual biological effect would be of great value.

The average dose is 1500 mrad per year, exceeding 3 times the maximum permissible dose.

International Commission on Radiological Protection and International Commission on Radiological Units and Measurements

G/R.117 EXPOSURE OF MAN TO IONIZING RADIATION ARISING FROM MEDICAL PROCEDURES

Gives a survey of the present exposure of the gonads due to X-ray diagnostic procedures. Some 85% of the diagnostic dose arises from 6 to 7 types of examinations, which are discussed separately. Estimates of the genetically significant dose are given for some countries. It is recommended that the basic studies be extended and that more detailed analysis be obtained through sampling procedures rather than through the systematic recording of the radiation received by every member of the population. Methods for dose reduction are discussed.

Italy

G/R.134 REPORT ON GENETICS 1950-1957—A BRIEF REPORT ON THE RESEARCH WORK DONE IN THE FIELD OF GENETICS IN ITALY

Extensive notes reporting relevant research work in the field of genetics carried out in Italy during the period 1950-1957.

G/R.195 DATA ON RADIOACTIVE FALLOUT COLLECTED IN ITALY (1956, 1957, 1958)

Japan

G/R.4 Report consisting of 8 parts, as follow:

PART 1. RESEARCHES ON THE EFFECTS OF THE H-BOMB EXPLOSION AT BIKINI ATOLL 1954 ON ANIMAL INDUSTRY AND SERICULTURE IN JAPAN

Gives negative results of analysis by absorption method of radioactivity in milk, eggs, and agricultural products following the Bikini explosions of May 1954. Related experimental feedings of animals with radioactive ashes were analyzed chemically.

PART 2. THE RADIOACTIVE CONTAMINATION OF AGRICULTURAL CROPS IN JAPAN

Gives results of soil and crop analyses for total radioactivity before and after the May 1954 Bikini explosions, after subtraction of K^{40} content, and with some radiochemical analysis. Radioactivity after the explosion was detected in soil, crops, and other vegetation which are distributed all over Japan. The possible route of contamination is discussed.

PART 3. A PRELIMINARY REPORT OF RECOMMENDATIONS ON THE MODERN METHODS OF ESTIMATING THE BIOLOGICAL ACTIVITY OF SMALL RADIATION DOSE

Several current hematological findings in Japan are summarized and discussed.

Japan (Continued)

PART 4. THE AIRBORNE RADIOACTIVITY IN JAPAN

Analyses of airborne radioactivity by filter and by electrical precipitator are described and compared. Results of analyses 1954-1956 show poor correlation between peaks of contamination and trajectories of high-level air masses.

PART 5. REPORT ON THE SYSTEMATIC OBSERVATIONS OF THE ATMOSPHERIC RADIOACTIVITY IN JAPAN

Describes methods of collection and analysis of fallout in dust, rain, and snow, and of airborne radioactivity, as used in a wide survey at meteorological stations. Results from April 1954-March 1956 are summarized and discussed and the cumulative depositions of Sr⁹⁰ are calculated.

PART 6. ON THE DISTRIBUTION OF NATURALLY RADIOACTIVE NUCLIDES IN JAPANESE ISLANDS

Surveys of the distribution of naturally radioactive nuclides in Japanese waters and minerals are reviewed and summarized.

PART 7. RADIOCHEMICAL ANALYSIS OF RADIOACTIVE FALLOUT OBSERVED IN JAPAN

Presents methods and results of radiochemical analyses of ash from the fishing boat No. 5 Fukuryu Maru and of rainwater and soil samples in Japan.

PART 8. FISSION PRODUCTS IN WATER AREA AND AQUATIC ORGANISMS

Describes fallout distribution and uptake generally, with special reference to water and aquatic organisms and to the problem of Sr⁹⁰.

G/R.43 THE EFFECT OF MOMENTARY X-RAY EXPOSURE IN A SMALL DOSE UPON THE PERIPHERAL BLOOD PICTURE

Decrease in lymphocyte number after single 60 mr exposure in humans. Decrease in lymphocyte count varies from 10 to 50%—the maximum drop occurs 30 minutes after irradiation, and may be followed by an increase in lymphocyte count.

G/R.44 HEMATOLOGICAL EFFECTS OF SINGLE EXPOSURE TO SMALL DOSES OF X-RAY

Hematological effects during routine chest examinations. Dosages up to 3 r. Most constantly observed are: increase in neutral red bodies and Demel's granules in lymphocytes and late decrease in mitochondrial index of lymphocytes during the four-hour period following the irradiation. The cytochemical identification of these various granules and their biological significance should be established unequivocally.

G/R.45 MORPHOLOGICAL CHANGES OF PLATELETS IN CHRONIC RADIATION INJURIES

Platelet morphology in chronic irradiation injury in rabbits (chronic 0.1152 or 0.2312), X-ray workers (dosage not evaluated) and persons exposed to atomic bomb within 4 km from epicenter (9 years after the exposure).

Even if platelet count is normal, area index (proportional to average area) is increased markedly, and may remain so 9 years after irradiation and is not necessarily related to low platelet count. Other morphological changes are also shown.

This observation should be repeated by other groups.

G/R.51 CURRENT AND PROPOSED PROGRAMMES OF RESEARCH AND INVESTIGATION RELATED TO RADIATION GENETICS IN JAPAN

A brief survey of current and planned research in Japan relevant to radiation genetics, covering both human surveys and experimental work.

Japan (Continued)

- G/R.61 TABLE 1(2) TO ABOVE REPORT: EXPERIMENTAL DATA WITH β RADIATION
(Add.1)
- G/R.62 RADIOCHEMICAL ANALYSIS OF Sr^{90} AND Cs^{137}
Discusses methods of radiochemical analysis of Sr^{90} and Cs^{137} , including separation of strontium by precipitation and by ion exchange. Experiments for determining the best conditions for ion exchange separations are reported.
- G/R.63 REVIEW OF THE RECENT RESEARCHES ON THE BIOLOGICAL EFFECTS OF IONIZING RADIATION IN JAPAN
Contains brief abstracts of 55 papers from the Japanese literature dealing with (1) research on biological indicators of the effects of ionizing radiation in small and large doses, and (2) research on counter measures to alleviate radiation injury. Classical and more modern morphological, histochemical, and biochemical methods of observation were used for the assessment of radiation damage. Most studies were performed on mammals. It is emphasized that it is very difficult to obtain reliable biological indicators of damage by small doses and that hematological methods are still the most suitable in man.
- G/R.70 RADIOLOGICAL DATA IN JAPAN
- G/R.70 Correction to above document.
(Corr.1)
- G/R.135 ANALYSIS OF Sr^{90} , CAESIUM-137 AND Pu^{239} IN FALLOUT AND CONTAMINATED MATERIALS
The report gives radiochemical procedures for Sr^{90} , Cs^{137} , and Pu^{239} from air filter ash. The counting equipment is described briefly.
- G/R.136 PRIMARY ESTIMATE OF THE DOSE GIVEN TO THE LUNGS BY THE AIRBORNE RADIOACTIVITY ORIGINATED BY THE NUCLEAR BOMB TESTS
The report gives method and results of measurement of airborne radioactivity for Tokyo from 1955-1957. Values are obtained for gross alpha and beta concentrations and radiochemically determined concentrations of Sr^{90} and Pu^{239} . A method for computation of the dose to the lungs is described. The mean dose during 1955-1957 was of the order of magnitude of 10^{-2} rem/year.
- G/R.136 Correction to above report.
(Corr.1)
- G/R.137 A MEASURE OF FUTURE STRONTIUM-90 LEVEL FROM EARTH SURFACE TO HUMAN BONE
Calculation of the future Sr^{90} level is made on the basis of present data on cumulative ground deposit and food contamination.
The cumulative ground deposit (mc/km^2) is calculated assuming that:
1. The total amount of fission products from future tests is known.
2. 20% of airborne Sr^{90} falls to the earth's surface every year.
3. The distribution of fallout is homogeneous.
The metabolism of Sr^{90} through the food channel and food habit factor related to calcium and strontium source are taken into consideration.
The future human skeletal dose and maximum permissible level of ground deposit are then calculated.
- G/R.138 SUPPLEMENTAL REVIEW OF THE RECENT RESEARCHES ON THE ALLEVIATION OF RADIATION HAZARDS
This is an addition to G/R.63 and gives abstracts of new developments of radiobiology in Japan. Work on protection by amino acids, cystamine and some new derivatives of this last compound is reported. Work on the therapeutic effect of a protein diet and of adrenochrome preparation is also reported.

Japan (Continued)

- G/R.138 Correction to above report.
(Corr.1)
- G/R.139 **EXPERIMENTAL STUDIES ON THE DEVELOPMENT OF LEUKEMIA IN MICE WITH FREQUENT ADMINISTRATIONS OF SMALL DOSES OF SOME RADIOACTIVE ISOTOPES (P-32, Sr-89, Ce-144)**
The development of leukemia is described in three strains of mice in which the disease has not been observed under control conditions. Nine cases of leukemia have been observed among 46 animals surviving 21 weeks and longer following the first of repeated administrations of P³² at three dose levels (0.1, 0.3, and 0.5 μc/g). Latent periods varied with total dose administered. Larger doses were more effective than small doses. The leukemias were primarily of the myeloid type.
Radiostrontium (Sr⁹⁰) and radio-cerium (Ce¹⁴⁴) were much less and practically ineffective in producing this disease in these animals. Sarcoma of bone was found in strontium-treated animals. It is concluded that leukemia is the result of severe damage to the haematopoietic tissues in the bone marrow and lymph nodes. There are many tables and figures, including results of radiochemical analyses of various bones at various intervals following injection.
- G/R.139 Correction to above report.
(Corr.1)
- G/R.140 **EXPERIMENTAL STUDIES ON COLLOIDAL RADIOACTIVE CHROMIC PHOSPHATE CrP³²O₄**
Describes morphological observations on the liver of rats which were injected intravenously with various concentrations of colloidal suspensions (particle size 0.1–1.0 micron) of radioactive chromium phosphate (CrP³²O₄). Even with high doses (7.5 μc/g) liver injury did not become manifest until 20 days after injection and correspondingly later with lower doses. Changes in the liver are described but not illustrated. They are greater in the liver than in other organs containing reticule-endothelial cells. The lesions are said to resemble those of virus hepatitis. Large doses of chromium phosphate also produce lesions in the bone marrow with concomitant changes in the peripheral blood.
- G/R.140 Correction to above report.
(Corr.1)
- G/R.141 **RADIOLOGICAL DATA IN JAPAN II—CONCENTRATIONS OF STRONTIUM 90, CAESIUM 137, Pu-239 AND OTHERS IN VARIOUS MATERIALS ON EARTH'S SURFACE**
Contains data on concentration of Sr⁹⁰ in rain water, soil, foodstuffs, and human bone in Japan obtained by radiochemical analysis in some cases and by computation from the total beta activity in other cases. Besides Sr⁹⁰, data on Cs¹³⁷, Pu²³⁹, Zn⁶⁵, Fe⁵⁵, and Cd¹¹³ are also included.
- G/R.141 Correction to above report.
(Corr.1)
- G/R.161 **A SENSITIVE METHOD FOR DETECTING THE EFFECT OF RADIATION UPON THE HUMAN BODY**
Discovery of a new extremely sensitive biological indicator of the effect of ionizing radiation. The acute dose of 50 mr and even less results in significant changes of the phosphene threshold of the eye. Approximately linear relationship between the effect and the logarithms of the dose from 1 mr to 50 mr is derived. Summation of the effect of repeated exposure is found.
- G/R.168 **AN ENUMERATION OF FUTURE Sr⁹⁰ CONCENTRATION IN FOODS AND BONE**
Gives amendments and corrections to the report G/R.137 based upon new available data.

Japan (Continued)

- G/R.172 THE ESTIMATION OF THE AMOUNT OF Sr⁹⁰ DEPOSITION AND THE EXTERNAL INFINITE GAMMA DOSE IN JAPAN DUE TO MAN-MADE RADIOACTIVITY

Korea

- G/R.18 REPORT CONCERNING THE REQUEST FOR INFORMATION ON NATURAL RADIATION BACKGROUND
Describes counters used for monitoring radiation background and gives results (cpm) from January 1955 to June 1956.

Mexico

- G/R.5 FIRST REPORT ON THE STUDIES OF RADIOACTIVE FALLOUT
Gives full description and comparisons of sticky paper and pot methods, preliminary results May-July 1956 for total β activity and intended expansion of programme.
- G/R.42 FIRST STUDIES ON RADIOACTIVE FALLOUT
Revised form of G/R.5.
- G/R.164 THIRD REPORT ON THE STUDIES ON RADIOACTIVE FALLOUT
Presents fallout data for 13 stations in Mexico covering the period from March to October 1957.
Computes approximate figures for infinite gamma dose and Sr⁹⁰ precipitation.
Gives preliminary results of Sr⁹⁰ and Cs¹³⁷ content in milk.
- G/R.187 SUMMARY OF RADIOACTIVE FALLOUT DATA RECORDED IN MEXICO

Netherlands

- G/R.59 RADIOACTIVE FALLOUT MEASUREMENTS IN THE NETHERLANDS
Describes methods used for collecting samples of airborne radioactivity and of deposited fallout, and methods of measurement.
Includes tables of results for 1955 and 1956; calculation of gamma doses and quantity of Sr⁹⁰ computed from total activity.
- G/R.90 CHEMICAL STEPS INVOLVED IN THE PRODUCTION OF MUTATIONS AND CHROMOSOME ABERRATION BY X-RADIATION AND CERTAIN CHEMICALS IN DROSOPHILA
A survey of comparative studies of X-ray and chemical mutagenesis in *Drosophila*, made in an attempt to throw light on possible intermediate chemical steps in the induction of chromosome breaks or mutations by ionizing radiation.
- G/R.110 FOUR REPORTS ON QUANTITATIVE DETERMINATION OF RADIOACTIVITY
- G/R.183 REPORT OF THE COMMITTEE OF THE ROYAL NETHERLANDS ACADEMY OF SCIENCES CONCERNING THE DANGERS WHICH MAY ARISE FROM THE DISSEMINATION OF RADIOACTIVE PRODUCTS THROUGH NUCLEAR TEST EXPLOSIONS
Report on the amount of radioactivity, its world-wide spreading and its biological risk as a consequence of test explosions.
- G/R.184 RADIOACTIVE FALLOUT MEASUREMENTS IN THE NETHERLANDS UNTIL DECEMBER 31, 1957
- G/R.184 Correction to above report.
(Corr.1)

New Zealand

G/R.13 NOTE BY NEW ZEALAND

Gives brief notes in reply to the questions contained in individual paragraphs of annexes to letter PO 131/224 of 9 April 1956 (Annexes derived from G/R.10). Other sections describe: measurements of radioactivity (only radon found) collected from air at Wellington by filter and by electrostatic precipitator February 1953 - May 1956, also by an impactor method in 1953 and in rain water on certain dates November 1955 - May 1956; results of measurements of total beta activities of fallout by sticky paper method May - July 1956.

G/R.107 NEW ZEALAND REPORT TO U. N. SCIENTIFIC COMMITTEE ON ATOMIC RADIATION: EFFECTS OF ATOMIC RADIATION MEASURED IN NEW ZEALAND TO 31 JULY 1957

A set of notes on the current status of various programs in New Zealand within the field of interest of the Scientific Committee on the Effects of Atomic Radiation, including preliminary measurement of radioactive fallout, C^{14} activity airborne, natural and artificial radioactivity, and occupational gonad exposures.

G/R.185 LETTER OF DEPARTMENT OF HEALTH, DOMINION X-RAY AND RADIUM LABORATORY, CHRIST CHURCH, NEW ZEALAND

Contains: (1) Description of radiation protection measures in New Zealand; (2) Results of routine monitoring of radiation workers; (3) Preliminary results of statistical study on genetically significant gonad dose from X-ray diagnosis.

Norway

G/R.14 REPORT OF 3 PARTS

Suggests taurine biochemistry and lens opacities as biological indicators for low doses. Gives notes on disposal of small amounts of radioactive wastes. Describes and gives results of analyses by pot method in 1956 of total beta activity due to fallout on ground, in air, in drinking water, and accumulated in snow falls. Includes some analyses for Sr^{90} .

G/R.92 RADIOACTIVE FALLOUT IN NORWAY

Contains information on methods and results of measurements of fallout in Norway.

G/R.106 INFORMATION ON RADIOLOGICAL DATA

Summary tables on radiological data in Norway with an extensive set of data on x-ray and natural radiation exposures.

G/R.106 (Add.1) Correction to above report.

G/R.111 ON THE DEPOSITION OF NUCLEAR BOMB DEBRIS IN RELATION TO AIR CONCENTRATION

Studies the relation between the deposition of fallout and the airborne activity. It appears that in 1956 - 1957 the fallout in the Oslo area was roughly proportional to the product of precipitation and airborne activity at ground level.

G/R.112 RADIOACTIVE FALLOUT IN NORWAY UP TO AUGUST 1957

Gives the results of measurement of fallout materials in air, precipitations, water, and other samples. Measurement of airborne activity at high altitudes are included. Sr^{90} values are computed from total β activity, a small number of samples having been checked by chemical analysis. Samples of water, milk, and urine have been analyzed for I^{131} .

G/R.113 RADIOCHEMICAL ANALYSIS OF FALLOUT IN NORWAY

Describes the methods used in Norway for determination of Sr^{90} , Cs^{137} , and I^{131} , and contains data of Sr^{90} and Cs^{137} activities in water and milk and I^{131} in milk, in the period February - June 1957.

Norway (Continued)

- G/R.144 RADIOACTIVE FALLOUT UP TO NOVEMBER 1957
A review is given of the monitoring in Norway of airborne activity and fallout of radioactive dust; also radioactive contamination in drinking water is reported.

Norway and Sweden

- G/R.77 RADIOACTIVE FALLOUT OVER THE SCANDINAVIAN PENINSULA BETWEEN JULY AND DECEMBER 1956
In this report, fallout and rain precipitation figures over the Scandinavian peninsula are discussed. Accumulated monthly fallout is reported for the period July - December 1956.

Poland

- G/R.118 REPORT ON MEASUREMENTS OF FALLOUT IN POLAND
Continuous measurements of global beta activity of fallout are reported for four stations in Poland.

Romania

- G/R.52 ORGANIZATION AND RESULTS IN RADIOBIOLOGICAL RESEARCH WORK IN THE ROMANIAN PEOPLE'S REPUBLIC
Describes the following:
1. and 2. Protective effect of narcosis during irradiation only.
3. After 325 r, up to 11 days narcosis increases biological effects (does not state what criteria of biological effect).
4. Hibernation (25°C) protects. Hibernation between 18° to 25°C enhances effect. Does not state if this is during or after irradiation.
5. Hematological tests for 350 r.
6. Caffeine or aktedron during irradiation enhances effect; caffeine or aktedron after irradiation diminishes effect.
Suggests roentgenotherapy under conditions of protection (narcosis). Gives programme for radiobiology research in 1956 - 1957.

Sweden

- G/R.15 REPORT OF 15 PARTS
The fifteen sections cover: consumption of the doses to the gonads of the population from various sources; thorough survey of natural radioactivity including estimates of weekly dose-rates; measurements of gamma radiation from the human body; measurements of fallout (1953 - 1956) including total beta activity, gamma ray spectrum, and migration of Sr⁹⁰ into soils, plants, and grazing animals, content of certain isotopes as well as research upon certain related physical quantities; considerations of occupational (medical) exposures. Methods used are extensively described throughout.
- G/R.69 DOES THERE EXIST MUTATIONAL ADAPTATION TO CHRONIC IRRADIATION?
- G/R.77 RADIOACTIVE FALLOUT OVER THE SCANDINAVIAN PENINSULA BETWEEN JULY AND DECEMBER, 1956
(See annotation under *Norway and Sweden*.)
- G/R.79 A SUGGESTED PROCEDURE FOR THE COLLECTION OF RADIOACTIVE FALLOUT
Proposes new method for evaluation of the external thirty-year dose due to the deposition of gamma-emitting isotopes, based upon a single beta measurement

Sweden (Continued)

for each sample and one caesium ratio chemical determination in a pooled sample.

A second part of the report describes a collecting procedure using ion exchange resins.

- G/R.145 UPTAKE OF STRONTIUM AND CAESIUM BY PLANTS GROWN IN SOILS OF DIFFERENT TEXTURE AND DIFFERENT CALCIUM AND POTASSIUM CONTENT
- G/R.146 THE RADIOACTIVE FALLOUT IN SWEDEN UP TO 1/7/57
Additional data to the report G/R.15 for the period up to June 1957 are given. The total activity, accumulated Sr⁹⁰ and Cs¹³⁷ amount and Sr⁹⁰ content in soil are measured.
- G/R.147 GAMMA RADIATION IN SOME SWEDISH FOODSTUFFS
Significant increase of radiation in milk, beef, cattle-bone, and vegetables was found during the period 1952-1956. No increase of gamma radiation in children in the corresponding period could be observed.
- G/R.148 PROGRESS REPORT ON THE METABOLISM OF FISSION PRODUCTS IN RUMINANTS
The excretion of radioactive fission products (Sr⁹⁰ and I¹³¹) in milk after oral administration is measured.
- G/R.149 A METHOD FOR MONTHLY COLLECTION OF RADIOACTIVE FALLOUT
Describes a collecting procedure using anion and cation exchange resins.
- G/R.150 THE COMPUTATION OF INFINITE PLANE 30-YEAR DOSES FROM RADIOACTIVE FALLOUT
Proposes new method for evaluation of the external 30-year dose due to the deposition of gamma emitting isotopes, based upon a single beta measurement for each sample and one Cs¹³⁷ ratio chemical determination in a pooled sample.
- G/R.151 THE CONTROL OF IRRADIATION OF POPULATIONS FROM NATURAL AND ARTIFICIAL SOURCES
Describes an automatic system for continuous indication and recording of very low radiation level; suggests the use of such instrument for public control purposes.
- G/R.173 TRANSFER OF STRONTIUM-90 FROM MOTHER TO FOETUS AT VARIOUS STAGES OF GESTATION IN MICE
Shows that no significant fixation of Sr⁹⁰ by the foetus can be detected before the 15th day of gestation. The increase of radioactivity corresponds with the intensity of ossification processes.
- G/R.174 THE RECOVERY PHENOMENON AFTER IRRADIATION IN DROSOPHILA MELANOGASTER
1. Recovery or differential sensitivity to X-rays.
Experimental results: lower rate of chromosome aberrations induced by X-ray if irradiated in anoxia in comparison with irradiation in air. Supports the hypothesis of recovery.
- G/R.174 (Add.1) THE RECOVERY PHENOMENON AFTER IRRADIATION IN DROSOPHILA MELANOGASTER
Indicates that both the spontaneous recovery and the differential sensitivity in sperm's genesis in *Drosophila* are responsible for the changes in the rate of chromosome breaks under conditions of irradiation.
- G/R.174 (Add.2) THE RECOVERY PHENOMENON AFTER IRRADIATION IN DROSOPHILA MELANOGASTER

Sweden (Continued)

Chromosomes breakage *per se* or their rejoining by recovery seems to have no genetic consequences.

- G/R.175 REPORTS ON SCIENTIFIC OBSERVATIONS AND EXPERIMENTS RELEVANT TO THE EFFECTS OF IONIZING RADIATION UPON MAN AND HIS ENVIRONMENT ALREADY UNDER WAY IN SWEDEN
- G/R.175
(Add.1) REPORT ON EXPERIMENTS ON THE INFLUENCE OF SELECTION PRESSURE ON IRRADIATED POPULATIONS OF *DROSOPHILA MELANOGASTER*
Attempts to determine the influence of high selection pressure in a population on the spread of radiation-induced genetic changes. No results are as yet available.
- G/R.175
(Add.2) STUDIES ON THE MUTAGENIC EFFECT OF X-RAYS
Summarizes the results of the work on radiation-induced chromosome breakage under various conditions.
- G/R.175
(Add.3) DOES THERE EXIST MUTATIONAL ADAPTATION TO CHRONIC IRRADIATION?
The results do not confirm the assumption that under the increased radiation-background mutational adaptations occur due to incorporation in the population of mutational isoalleles with lower mutability.
- G/R.175
(Add.4) SOME RESULTS AND PREVIEWS OF RESEARCH IN SWEDEN. RELEVANT TO HUMAN RADIATION GENETICS
Summarizes the present state of knowledge and recommends: (1) Large scale international investigation of genetic consequences in females who have been controlled by means of X-rays due to congenital dislocation of the hip. (2) The study of genetic effects of radiation on human cell cultures.
- G/R.175
(Add.5) SUMMARY OF PAPERS OF LARS EHRENBERG AND COWORKERS WITH REGARDS TO THE QUESTIONS OF THE U. N. RADIATION COMMITTEE
Summary of papers of L. Ehrenberg and coworkers on genetic effects of radiation.
- G/R.175
(Add.6) STUDIES ON THE EFFECTS OF IRRADIATION ON PLANT MATERIAL CARRIED OUT DURING RECENT YEARS AT THE INSTITUTE FOR PHYSIOLOGIC BOTANY OF UPPSALA UNIVERSITY
- G/R.175
(Add.7) SWEDISH MUTATION RESEARCH IN PLANTS
- G/R.175
(Add.8) DR. GUNNAR OSTERGREN AND CO-WORKERS
Study on experimentally induced chromosome fragmentation.
- G/R.175
(Add.9) INVESTIGATIONS CARRIED OUT BY DR. C. A. LARSON (HUMAN GENETICS)
- G/R.176 SOME NOTES ON SKIN DOSES AND BONE MARROW DOSES IN MASS MINIATURE RADIOGRAPHY
- G/R.177 INVESTIGATIONS INTO THE HEALTH AND BLOOD PICTURE OF SWEDISH WOMEN LIVING IN HOUSES REPRESENTING DIFFERENT LEVELS OF IONIZING RADIATION
No difference was found either in general health-state or in blood picture among the various groups of individuals (over 2000 women) living in different types of dwelling.
- G/R.178 11 OTHER HAEMOPOIETIC FUNCTIONS: READ-OFF METHODS IN RADIO-HAEMATOLOGICAL CONTROL
Proposes a statistical method of evaluating total white-cells count as a control test of radiation damage.

Sweden (Continued)

- G/R.181 **BONE AND RADIOSTRONTIUM**
The local radiation dose to the bone tissue and to the bone marrow after administration of bone-seeking isotopes is discussed. The figures are compared with the maximum permissible body burden.
- G/R.182 **RADIATION DOSES TO THE GONADS OF PATIENTS IN SWEDISH ROENTGEN DIAGNOSTICS. SUMMARY OF STUDIES ON MAGNITUDE AND VARIATION OF THE GONAD DOSES TOGETHER WITH DOSE REDUCING MEASURES**

Switzerland

- G/R.27 **LETTER FROM THE "SERVICE FÉDÉRAL DE L'HYGIÈNE PUBLICQUE," BERN**
Gives brief description of works on studies of atomic radiations conducted in Switzerland.

Union of Soviet Socialist Republics

- G/R.37 **ON THE METHODS OF INDICATING THE CHANGES PRODUCED IN THE ORGANISM BY SMALL DOSES OF IONIZING RADIATION**
Gives an enumeration of many methods which might be used as tests for small dosages; but these are based on certain symptoms which have not yet been worked out to give a quantitative response; i.e., vegetative-visceral symptoms, nervous symptoms (like the increase in threshold of gustatory and olfactory sensitivity, etc.), skin vascular reactions, electroencephalogram.
Blood symptoms are also described (alterations of thrombocytes and lack of a leucocytosis response to the injection of Vit. B-12).
Certain "immunological" symptoms are quoted, such as the bactericidal properties of saliva and of skin.
- G/R.39 **CONTENT OF NATURAL RADIOACTIVE SUBSTANCES IN THE ATMOSPHERE AND IN WATER IN THE TERRITORY OF THE UNION OF SOVIET SOCIALIST REPUBLICS**
Studies content of natural radioactive substances in the atmosphere and in waters; geochemical considerations on mechanism of contamination of waters and description of radiohydrogeological methods. Gives methods of measurement of airborne activity and results, and includes tables giving content of natural radioactive products in air and waters.
- G/R.40 **STUDY OF THE ATMOSPHERIC CONTENT OF STRONTIUM-90 AND OTHER LONG-LIVED FISSION PRODUCTS**
Gives measurements of airborne fission products (Sr^{90} , Cs^{137} , Ce^{144} , and Ru^{106}); methods for collection of samples and of their radiochemical analysis; results and comments.
- G/R.41 **ON THE BEHAVIOR OF RADIOACTIVE FISSION PRODUCTS IN SOILS, THEIR ABSORPTION BY PLANTS AND THEIR ACCUMULATION IN CROPS**
Report made in two parts
Part I. Experiments of absorption and desorption by soil of fission products and especially of isotopes such as $\text{Sr}^{90} + \text{Y}^{90}$, Cs^{137} , $\text{Zr}^{95} + \text{Nb}^{95}$ and $\text{Ru}^{106} + \text{Rh}^{106}$ are described. Theoretical analysis is also described.
It was observed that $\text{Sr}^{90} + \text{Y}^{90}$ is absorbed through ion exchange reaction, and is completely or almost completely displaced from the absorbed state under the action of a neutral salt such as CaCl_2 . Radioactive equilibrium between Sr^{90} and Y^{90} is destroyed during the interaction with soil.

Union of Soviet Socialist Republics (Continued)

Displacement of absorbed radiocesium is greatly affected by the potassium ions, but not highly affected by NaNO_3 or CaCl_2 compared with $\text{Sr}^{90} + \text{Y}^{90}$. Zirconium and ruthenium absorbed by soil exhibit a much lower susceptibility to desorption into neutral salt solution, though their absorption is less complete. The disturbance of the equilibrium occurs also by absorption or desorption.

Part II. The results of experiments on uptake of fission products by several agricultural plants are described. In water culture, the bulk of radioactive isotopes of cesium and strontium is held in the above-ground organ of plant, while Zr, Rh^{106} , and Ce are mainly retained in the root system. Sr and Cs are likely to accumulate in reproductive organs of plants in larger quantities than Zr, Ru, and Ce. The plant uptake is affected by the concentration of hydrogen ions in the solution. Plants' uptake of fission products from soils is considerably smaller than from aqueous solution, and cesium was found to be less absorbable from soil, compared with other isotopes, while cesium is among the fission products most strongly absorbed by plants in water culture. These facts can be explained by the absorptive and desorptive capacity of the isotopes of the soil. The properties of soil as well as the application of lime, potassium or mineral fertilizers greatly affect the plant uptake. When a solution of fission products was applied to leaves of a plant, radioisotopes were observed to pass to other organs. Radiocesium was the most transmovable among the isotopes tested.

G/R.47 **PRELIMINARY DATA ON THE EFFECTS OF ATOMIC BOMB EXPLOSIONS ON THE CONCENTRATION OF ARTIFICIAL RADIOACTIVITY IN THE LOWER LEVELS OF THE ATMOSPHERE AND IN THE SOIL**

Contains description of methods of measurement of radioactive products in the air at ground level and high altitude and gives results of observations.

Also contains the following conclusions:

1. The existing technique for detecting the presence of artificial radioactivity in the lower atmosphere and the technique for determining the integral activity for aerosols deposited on the earth's surface makes it possible to estimate the level of contamination of the soil by radiostrontium (Sr^{90}).

2. The accumulation of radiostrontium in the soil in various areas of USSR territory is attributable partly to the explosion of atomic bombs in USA and partly to explosions set off in USSR. The lower limit of activity of the Sr^{90} which has accumulated in the past two years (1954-1955) is as high as about 30 millicuries per km^2 in certain towns (cf., for example, Adler).

3. Since radiostrontium is readily caught up in the biological cycle, suitable projects must be put in hand to determine the permissible levels of contamination of the soil with radiostrontium (Sr^{90}) and other biologically dangerous isotopes.

G/R.48 **PROGRAMME OF SCIENTIFIC RESEARCH ON THE EFFECTS OF IONIZING RADIATIONS ON THE HEALTH OF PRESENT AND FUTURE GENERATIONS**

Describes a programme of research intending to study the effects of radiation at dosages 1 or 2 orders of magnitude above background intensity, of contamination of the air and soil and life in areas of high natural radioactivity.

G/R.49 **SUMMARIES OF PAPERS PRESENTED AT THE CONFERENCE ON THE REMOTE CONSEQUENCES OF INJURIES CAUSED BY THE ACTION OF IONIZING RADIATION**

Mostly concerned with effects of various radionuclides and external radiation on different mammalian populations (hematology, carcinogenesis, fertility mostly studied). Twenty-two papers are summarized.

G/R.50 **CONTRIBUTIONS TO THE STUDY OF THE METABOLISM OF CESIUM, STRONTIUM, AND A MIXTURE OF BETA EMITTERS IN COWS**

The metabolism of Cs^{137} , $\text{Sr}^{89,90}$ and a number of mixed beta emitters has been studied in cows (milk, urine, feces, tissues).

Union of Soviet Socialist Republics (Continued)

Strontium: about 10% given is absorbed in intestine and 1.45% is retained in bones, and twenty times less in the soft tissues. The rest is excreted by milk or urine.

Cesium: about 25% given is absorbed in intestine—one fifth of this is retained in muscle and less than one tenth of this amount in other organs or skeleton; the rest is eliminated in the milk or urine.

- G/R.53 Report consists of two articles
1. THE EFFECTS OF IONIZING RADIATIONS ON THE ELECTRICAL ACTIVITY OF THE BRAIN
 - (a) Grigorev's research work states: γ rays depress electrical action of human brain. Does not confirm Eldrid-Trowbridge, who do not find effect on monkey.
 - (b) Describes effects of β rays of P^{32} (0.05 mc/kg up to 1 mc/kg) on electroencephalogram of dogs. This was followed by radiation sickness (if dose >0.5 mc/kg) and hematological effects. A special implantation method of the electrodes is used. Injection of 0.09 mc/kg gives change in amplitude 5 minutes after (reduction in amplitude). Id. when 0.5 mc—lowering of electrical activity lasts for several days. For dosages above 0.1 mc, part of the repression of brain activity is probably a result of the radiation sickness induced by such high dosages.
 2. ON THE BETA RADIATION ACTIVITY OF HUMAN BLOOD

Report on radioactivity of human blood: 100 cc of normal blood have a radioactivity of 1.7 to 3.64 10^{-10} curies (due to K^{40}). Permits determination of K content of whole blood. Same values are found in different pathological conditions. No data on people working with radioactive material.
- G/R.160 DRAFT OF CHAPTER F PREPARED BY THE DELEGATION OF THE U.S.S.R. TO THE SCIENTIFIC COMMITTEE ON THE EFFECTS OF ATOMIC RADIATION
- G/R.163 DATA ON THE RADIOACTIVE STRONTIUM FALLOUT ON THE TERRITORY OF THE U.S.S.R. TO THE END OF 1955
- G/R.196 DRAFT CHAPTER ON "GENETIC EFFECTS OF RADIATION" FOR THE REPORT TO BE TRANSMITTED BY THE SCIENTIFIC COMMITTEE ON THE EFFECTS OF ATOMIC RADIATION TO THE GENERAL ASSEMBLY IN 1958
- G/R.197 DRAFT CHAPTER ON "CONCLUSIONS AND RECOMMENDATIONS" FOR THE REPORT TO BE TRANSMITTED BY THE SCIENTIFIC COMMITTEE ON THE EFFECTS OF ATOMIC RADIATION TO THE GENERAL ASSEMBLY IN 1958
- G/R.198 CONTAMINATION OF THE BIOSPHERE IN THE VICINITY OF LENINGRAD BY THE PRODUCTS OF NUCLEAR EXPLOSIONS

Contains the description of methods used for monitoring the fallout deposition. Results for the period 1953–1957 are given. Data on specific activity of water from the river Neva, the sea, and the water supply system are also included. Accumulated radioactivity on the ground and external dose from radioactive deposit are then computed. Special attention is given to the contamination of the biosphere by Sr^{90} . Data are based on Hunter and Ballou's calculation.
- G/R.199 STUDY OF THE STRONTIUM-90 CONTENT OF THE ATMOSPHERE, SOIL, FOODSTUFFS, AND HUMAN BONES IN THE USSR

The Sr^{90} content of the air, soil, milk, and cereals in various districts of the USSR was determined by radiochemical analysis. Preliminary results on the Sr^{90} content in bones from children in the Moscow district give the average value of 2, 3 S.U. in the second half of 1957. A few data on Cs^{137} concentration in the air are attached.

Union of Soviet Socialist Republics (Continued)

- G/R.200 **UPTAKE OF RADIOACTIVE STRONTIUM BY PLANTS AND ITS ACCUMULATION IN VARIOUS AGRICULTURAL CROPS**
Detailed analysis of Sr⁹⁰ uptake by plants in relation to their biological characteristic (plant species, vegetative period) and the properties of the soil.
Both factors can influence to a large extent the incorporation of Sr⁹⁰ during the biological cycle.
- G/R.201 **SOME RESULTS OF A STUDY OF THE BONE SYSTEM AFTER INJURY BY RADIOACTIVE STRONTIUM**
Reviews the experimental results obtained in the studies on the effect of bone-seeking radioisotopes. The progressive pathological changes leading to the development of bone tumors are described. The disturbances in the osteogenetic processes during the initial stages after contamination are marked pretumorous changes; their histological characteristic and their pathogenetic significance are discussed.
- G/R.202 **BLASTOMEGENIC EFFECTS OF STRONTIUM-90**
Summarizes and evaluates the results so far published on the cancerogenic effect of Sr⁹⁰ in bone. In particular, the minimum and optimum tumor-producing doses, the latent period and the distribution of Sr⁹⁰ are discussed. The connection between the blastomogenic effect and the development of leukemia is briefly mentioned.
- G/R.203 **THE RADIATION HAZARDS OF EXPLOSIONS OF PURE HYDROGEN AND ORDINARY ATOMIC BOMBS**
Compares the hazards of the long-lived radioactive substances dispersed throughout the world after the explosion of a fission and a pure fusion bomb. Radiation doses to the gonads and bones are calculated and the number of persons affected (hereditary diseases and leukemia) then computed. The conclusion is drawn that a pure fusion bomb cannot be regarded as less dangerous to mankind than a fission bomb.
- G/R.204 **TOWARDS AN ASSESSMENT OF THE HAZARD FROM RADIOACTIVE FALLOUT**
An attempt to assess the various forms of hazard involved in the contamination of the earth's surface with long-lived radioactive fission products. The particular importance of Sr⁹⁰ is stressed. Effects of small doses of radiation and the concept of maximum permissible dose are discussed.
- G/R.205 **NATURE OF THE INITIAL EFFECT OF RADIATION ON THE HEREDITARY STRUCTURES**
A survey of the present knowledge of the nature of the primary mechanisms through which ionizing radiation damages the hereditary structures.
- G/R.206 **RADIATION AND HUMAN HEREDITARY**
Emphasizes the importance of the basic scientific principles of radiation genetics for the assessment of radiation-induced changes in human heredity. The natural mutation rate for various hereditary abnormalities is compared with the observations so far available on irradiated human population. The comparison of natural and induced mutagenesis both in experimental organisms and in men is the basis on which the doubling dose for man was estimated as approximately 10 r. The lack of exact knowledge and the urgent need for it is stressed.
- G/R.207 **THE EFFECT OF RADIATION ON THE HISTOLOGICAL STRUCTURE OF MONKEY TESTES**
Presents the results of histological analysis of monkey testes two years after exposure to a dose of 150–450 r. While the recovery process proceeds rapidly and is apparently complete in animals irradiated after the attainment of sexual

Union of Soviet Socialist Republics (Continued)

maturity, harmful disturbances have been found in young animals even two years after exposure.

G/R.208 THE CYTOGENETIC EFFECTS OF RADIATION EXPOSURE ON SPERMATOGENESIS IN MONKEYS

Presents the results of cytological analysis of monkey testes two years after exposure to a dose of 150–450 r. Extensive damage to the spermatogenesis was found. The frequency of chromosome rearrangements in mammals considerably exceeds that in *Drosophila* after exposure to the same dose, being 65% and 1.6% after 500 r respectively.

Union of South Africa

G/R.6 PRELIMINARY REPORT ON RADIOACTIVE FALLOUT

The preliminary result of the measurement of total β activity of fallout by porcelain dish method is described and results are given for January–June 1956. Sr^{90} deposition was estimated by chemical analysis.

United Arab Republic

G/R.191 RADIOACTIVE FALLOUT IN EGYPT: DECEMBER, 1956 – FEBRUARY 1957

G/R.192 RADIOACTIVE FALLOUT IN EGYPT: MARCH–DECEMBER 1957

G/R.193 SOME SOMATIC CHANGES OBSERVED IN CULEX MOLESTUS FORSKAL 1775

Shows differences in the uptake of P^{32} in dependence upon the development stage and sex. The explanation of sex-difference is discussed.

UNESCO/FAO/WHO

G/R.162 UNESCO/FAO/WHO REPORT ON SEA AND OCEAN DISPOSAL OF RADIOACTIVE WASTES, INCLUDING APPENDICES A, B, AND C

Summarizes contributions made by different authorities.

Appendix A. R. Reville and M. B. Schaefer. General considerations concerning the ocean as a receptacle for artificially radioactive materials.

Contains general account of the processes in the oceans and indicates the necessity of research on certain basic problems which would enable prediction of the consequences of the disposal of large quantities of radioactive material at sea.

Recommends measures of an international character in order to assure safe liquidation of atomic wastes.

Appendix B. Report prepared by FAO and WHO. Discusses the questions:

1. The geochemical cycle of various elements between the water and the sediments.
2. The affinities of the various species of organisms in the oceans for different elements which have radioactive isotopes.
3. The possible rate and distance of vertical and horizontal transport of radioactive isotopes by marine organisms.
4. The distribution, abundance, and rate of growth of the populations in the oceans.

Appendix C. Abstracts of eight other contributions to the report on sea and ocean disposal of radioactive wastes.

United Kingdom

- G/R.2 **THE HAZARDS TO MAN OF NUCLEAR AND ALLIED RADIATIONS**
General report covers both somatic and genetic hazards associated with radiation, present and foreseeable levels of exposure, and an assessment of the hazards in terms of associated actual and permissible levels.
- G/R.20 **THE RADIOLOGICAL DOSE TO PERSONS IN THE UNITED KINGDOM DUE TO DEBRIS FROM NUCLEAR TEST EXPLOSIONS PRIOR TO JANUARY 1956**
Summarizes measurements of total beta activity and Sr⁹⁰ content of fallout at ground stations, in rain water and in the air over the United Kingdom during 1952-1955. Includes calculations of time-integrated gamma ray doses.
- G/R.30 **RADIOSTRONTIUM FALLOUT IN BIOLOGICAL MATERIALS IN BRITAIN**
Describes methods for determination of Sr⁹⁰ in soils and material of the biological cycle; gives results of measurement effected in England up to Spring 1956.
- G/R.51 **THE GENETICALLY SIGNIFICANT RADIATION DOSE FROM THE DIAGNOSTIC USE OF X-RAYS IN ENGLAND AND WALES—A PRELIMINARY SURVEY**
Contains an analysis of number of X-ray diagnostic examinations performed per annum in England and Wales, and a subdivision obtained from five selected hospitals into types of examinations, and into age and sex of the patients examined. In addition, an assessment is made of the minimum dose received by the gonads in each type of examination, and the probability of reproduction as a function of age. The results show that it is unlikely that the genetically significant radiation dose received by the population of England and Wales from X-ray diagnosis amounts to less than 22% of that received from natural sources and it may well be several times greater than this figure. Most of this radiation is received in a few types of examinations, undergone by relatively few patients, and by foetal gonads in examinations during pregnancy.
- G/R.60 **GENETIC RESEARCH IN THE UNITED KINGDOM**
Relevant programmes of genetic research in the United Kingdom and their investigators concerned are listed under the headings.
(i) fundamental research upon mechanisms
(ii) population structure
(iii) quantitative data on human mutation
- G/R.60 **SUGGESTIONS FOR RESEARCH IN RADIATION GENETICS**
(Add.1) General considerations are reviewed and a list of suggested programmes of research in the fields of (i) to (iii) is appended.
- G/R.100 **THE DETERMINATION OF LONG-LIVED FALLOUT IN RAIN WATER**
Describes radiochemical procedures for the determination of Sr⁸⁹, Sr⁹⁰, Cs¹³⁷, and Ce¹⁴⁴ activities in the rain water.
- G/R.103 **MODIFICATION OF IMMUNOLOGICAL PHENOMENA AND PATHOGENIC ACTION OF INFECTIOUS AGENTS AFTER IRRADIATION OF THE HOST**
Evidence is given that whole body irradiation before the repeated injection of antigen both diminishes the peak-concentration of antibody and delays in time the appearance of the peak. The lowest efficient dose was 25 r. The tolerance of heterogeneous skin grafts or bone marrow cells has been also shown after irradiation; the duration of inhibition of immune response is proportional to dose received.
- G/R.104 **SOME DATA, ESTIMATES, AND REFLECTIONS ON CONGENITAL AND HEREDITARY ANOMALIES IN THE POPULATION OF NORTHERN IRELAND**
Presents an extremely detailed and thorough medicogenetic survey of the population of Northern Ireland using data accumulated over a number of years,

United Kingdom (Continued)

together with very pertinent analyses of the data, the problem of genetic disability and its relation to radiation effects.

G/R.105 LEUKEMIA AND APLASTIC ANEMIA IN PATIENTS IRRADIATED FOR ANKYLOSING SPONDYLITIS

The incidence of leukemia and of aplastic anemia was investigated in patients treated in Britain for ankylosing spondylitis by means of ionizing radiations during the years 1935-1954.

Relationship between radiation dose and incidence of leukemia was evaluated. The answers suggest the adoption of working hypothesis that for low doses the incidence of leukemia bears a simple proportional relationship to the dose of radiation, and that there is no threshold dose for the induction of the disease. The dose to the whole bone marrow which would have doubled the expected incidence of leukemia may lie within 30 to 50 r for irradiation with X-rays.

G/R.114 THE RELATIVE HAZARDS OF STRONTIUM-90 AND RADIUM-226

Methods for calculations of the doses received by soft tissue cavities in bone containing Sr^{90} and Ra^{226} are presented. Non-uniformity factors are given for the dose from Sr^{90} . Calculation of the maximum permissible body burden for radium on the basis of a given maximum permissible dose-rate to bone gives a wide range of values, depending on the assumptions made. In the case of radiostrontium, the range of possible values is less. It is suggested that radium be no longer taken as the basis for the calculation of maximum permissible body burden of Sr^{90} .

G/R.115 SHORTENING OF LIFE BY CHRONIC IRRADIATION: THE EXPERIMENTAL FACTS

A survey of all published experimental results relating to shortening of life-span of mice due to chronic irradiation.

The comparison of effects between gamma-rays of Co^{60} and fast neutrons is made; the R.B.E. factor used for fast neutrons was 13.

A good agreement of experimental results has been found indicating that chronic irradiation both with gamma-rays and neutrons shortens the life of mice in a reproducible manner. No statistically significant data were found below the weekly dose of 10 r.

The possibility of extrapolation and the possible dose-effect relationship is discussed.

G/R.126 RADIOSTRONTIUM IN SOIL, GRASS, MILK, AND BONE IN U. K. 1956 RESULTS

Results of Sr^{90} analysis of soil, grass, and animal bone for 12 stations in U. K. are given. Human bone specimens obtained in 1956 have also been measured.

G/R.128 IONIZING RADIATION AND THE SOCIALLY HANDICAPPED

Collects available data and calculations concerning the numbers in various classes of handicapped individuals in the U. K. and the relationships of these numbers to genetic factors, mutation rates, and radiation levels.

G/R.132 THE DETERMINATION OF LONG-LIVED FALLOUT IN RAIN WATER

A method is described for the determination of long-lived isotopes in samples of rain water. Some attention is paid to the development of the method, including details of the checks to ensure radiochemical purity of the final sources used for counting.

G/R.143 THE WORLD-WIDE DEPOSITION OF LONG-LIVED FISSION PRODUCTS FROM NUCLEAR TEST EXPLOSIONS

A network of 6 stations in the U.K. and 13 other parts of the world has been set up for rain water collection. Samples are analyzed for Sr^{90} , Sr^{90} , Cs^{137} , and Ce^{144} . This report contains an account of the results obtained so far, and some discussion of the present and future levels of Sr^{90} in U.K. soil.

United Kingdom (Continued)

- G/R.152 **THE ANALYSIS OF LOW LEVEL GAMMA-RAY ACTIVITY BY SCINTILLATION SPECTROMETRY**
The application of gamma-ray spectrometry enables measurement of the gamma-activity of 10^{-11} curies or less.
- G/R.167 **MEASUREMENTS OF Cs¹³⁷ IN HUMAN BEINGS IN THE UNITED KINGDOM 1956/1957**
Describes the method of determining the Cs¹³⁷ content in the human body using gamma-ray spectrometry.
The average present value is 34.0 ± 7.6 μc per g potassium.
- G/R.170 **THE DISPOSAL OF RADIOACTIVE WASTE TO THE SEA DURING 1956 BY THE UNITED KINGDOM ATOMIC ENERGY AUTHORITY**
Summarizes the discharges of liquid radioactive wastes to the coastal sea from Windscale Works during 1956.
The results of monitoring indicate that the average activity of the samples remains well below the permissible level.
- G/R.171 **A SUMMARY OF THE BIOLOGICAL INVESTIGATIONS OF THE DISCHARGES OF AQUEOUS RADIOACTIVE WASTE TO THE SEA FROM WINDSCALE WORKS, SELLAFIELD, CUMBERLAND**
Summarizes the results of preliminary hydrographic and biological studies and of regular monitoring of the marine environment in the period 1952-1956. About 2,500 curies of radioactive wastes monthly has been discharged during this period. Due to the favorable local conditions, the upper limit for safe liquidation is determined to be more than 45,000 curies per month.

United States of America

- G/R.1 **THE BIOLOGICAL EFFECTS OF ATOMIC RADIATION**
Summarizes general survey in which committees of experts covered the following subjects: genetics; pathology; meteorology; oceanography and fisheries; agriculture and food supplies; disposal and disposers of radioactive wastes.
- G/R.7 **RADIOACTIVE FALLOUT THROUGH SEPTEMBER 1955**
Summarizes analysis of daily samples obtained up to end of September 1955 from 26 stations in United States and 62 elsewhere by gummed film method calibrated against collection in high walled pots (see A/AC.82/INF.1). Cumulative deposition of mixed fission products, integral gamma doses and Sr⁹⁰ deposits are calculated and compared with other findings, including Sr⁹⁰ content of soils and milk.
- G/R.11 **PATHOLOGIC EFFECTS OF ATOMIC RADIATION**
Present knowledge of the pathological (non-hereditary) effects of radiation are surveyed extensively by a committee. Includes separate sections by sub-committees or individual members on: acute and long-term hematological effects; toxicity of internal emitters; acute and chronic effects of radioactive particles on the respiratory tract, delayed effects of ionizing radiations from external sources; effects of radiation on the embryo and foetus; radiation in a disturbed environment; effects of irradiation of the nervous system; radiation effects on endocrine organs.
- G/R.21 **PROJECT SUNSHINE BULLETIN NO. 12**
Presents and discusses results of Sr⁹⁰ analysis since 1 December 1955. Includes Sr⁹⁰ concentration in human and animal bones, animal products, vegetation, soil, precipitation, other water, and air.

United States of America (Continued)

- G/R.22 **SUMMARY OF ANALYTICAL RESULTS FROM THE HASL STRONTIUM PROGRAM TO JUNE 1956**
Summarizes the data of research on Sr⁹⁰ conducted by HASL since 1951. Includes Sr⁹⁰ content in fallout, soil, vegetation, human and animal bones, human urine, milk, cheese, drinking water, and fish. Fallout measurements and samples cover not only United States of America but also several other countries.
- G/R.24 **THE EFFECT OF EXPOSURE TO THE ATOMIC BOMBS OF PREGNANCY TERMINATION IN HIROSHIMA AND NAGASAKI**
Gives full account of survey of pregnancies in Nagasaki and Hiroshima from 1948 to 1954: sex ratio, congenital malformations, still births, birthweights, neo-natal deaths, certain anthropometric measurements at 9 months, and autopsies were compared with parental irradiation histories. No significant correlations were found.
- G/R.54 **SOME EFFECTS OF IONIZING RADIATION ON HUMAN BEINGS**
A report on the Marshallese and Americans accidentally exposed to radiation from fallout and a discussion of radiation injury in the human being. Gives general and clinical symptomatology in relation to the estimated dosage and to internally deposited radionuclides.
- G/R.55 **BACKGROUND RADIATION—A LITERATURE SEARCH**
The results of literature search about background radiations to human beings are described and classified into three categories: (1) cosmic radiation; (2) terrestrial radiation sources; and (3) radiation from internal emitter.
The cosmic radiation is important for the evaluation of natural background, since it is estimated very roughly to contribute about a quarter of total background dosage to the human population at sea level and high latitude. However, its intensity varies with various factors, such as altitude, geomagnetic latitude, barometric pressure, temperature, etc. Facts directly related to biological effects of cosmic rays are also reviewed.
Radiations from naturally occurring radioactive isotopes form another important part of the natural background. The contribution which comes from land is mainly due to K⁴⁰, Ra²²⁶, Th²³², and U²³⁸ and the decay products of the last three nuclides. The radium concentrations in surface water and public water supplies in various districts are tabulated. The atmospheric concentration of Rn and Th is greatly dependent on the locality, atmospheric condition, and degree of ventilation, if indoor.
The population dose due to the natural background radiation is difficult to evaluate in general, because of the statistical nature and varying conditions involved in nations.
- G/R.56 **OPERATION TROLL**
Operation Troll was conducted to survey the radioactivity in sea water and marine life in the Pacific area during the period from February to May 1955. The general conclusions obtained are as follows:
1. Sea water and plankton samples show the existence of widespread low-level activity in the Pacific Ocean. Water activity ranged from 0-579 d/min/liter and plankton from 3-140 d/min/g wet weight.
2. There is some concentration of the activity in the main current streams, such as the North Equatorial Current. The highest activity was off the coast of Luzon, averaging 190 d/min/liter down to 600 m (1 April 1955).
3. Analyses of fish indicate no activity approaching the maximum permissible level for foods. The highest activity in tuna fish was 3.5 d/min/g ash, less than 1 per cent of the permissible level.
4. Measurements of plankton activity offer a sensitive indication of activity in the ocean.

United States of America (Continued)

5. Similar operations would be valuable in assessing the activity from future tests and in gathering valuable data for oceanographic studies.

- G/R.57 **GONADAL DOSE IN ROENTGEN EXAMINATIONS—A LITERATURE SEARCH**
Contains results of literature research which show the estimated contribution of gonadal dose by standard medical roentgenographic procedures. Contribution to the gonadal dose of certain examinations, such as examinations of teeth, skull, chest, and extremities, is relatively insignificant, when compared to the case of pelvic and abdominal examinations. It should be noticed that the dose to the foetal gonad is important genetically.
- G/R.64 **SHORTENING OF LIFE IN THE OFFSPRING OF MALE MICE EXPOSED TO NEUTRON RADIATION FROM AN ATOMIC BOMB**
Length of life in the offspring of male mice exposed to moderate doses of acute neutron radiation from a nuclear detonation is shortened by 0.61 days for each rep received by the father over the dose range tested. This figure excludes death before weaning age. The 95% confidence limits are 0.14 and 1.07 days per rep. Extrapolating to a proportional shortening of life in man gives 20 days per rep received by the father as the point estimate and 5 and 35 days as the 95% confidence limits. The offspring were obtained from matings made from 19 to 23 days after irradiation and, therefore, represent the effect of irradiation on germ cells in post-spermatogonial and sensitive stage of gametogenesis. It is probable that irradiation of spermatogonia (the stage that is important from the point of view of human hazards) would give a somewhat smaller effect. However, since the present data show an effect on the offspring which is as large as the shortening of life in the exposed individuals themselves, it seems likely that, even when allowance is made for the conditions of human radiation exposure, shortening of life in the immediate descendents will turn out to be of a magnitude that will warrant serious consideration as a genetic hazard in man.
- G/R.65 **GAMMA-RAY SENSITIVITY OF SPERMATOGONIA OF THE MOUSE**
Relates the depletion of spermatogenic cells to killing of spermatogonia, the repopulation being related to the maturation of surviving cells.
- G/R.66 **SOME DELAYED EFFECTS OF LOW DOSES OF IONIZING RADIATIONS IN SMALL LABORATORY ANIMALS**
A quantitative study of the life span, the incidence of leukemia, tumors (lung, liver, ovary), and lens opacities as a response to low dosages (less than 100 rads).
- G/R.67 **EFFECTS OF LOW-LEVEL RADIATION (1 TO 3 r) MITOTIC RATE OF GRASS-HOPPER NEUROBLASTS**
A study of the inhibitions of mitotic rate and of its possible relationship with the alteration of chromosome structure.
- G/R.68 **EFFECTS OF LOW DOSES OF X-RAYS ON EMBRYONIC DEVELOPMENT IN THE MOUSE**
Effects of 25 r applied during different stages of embryonic development on skeletal malformations appearing in the young.
- G/R.71 **OCCUPATIONAL RADIATION EXPOSURES IN U. S. ATOMIC ENERGY PROJECTS**
- G/R.72 **WORLDWIDE EFFECTS OF ATOMIC WEAPONS**
(A comprehensive preliminary report on the Sr⁹⁰ problem up to 1953)
A preliminary report discussing the various aspects of long-range contamination due to the detonation of large numbers of nuclear devices. An improved methodology for assessing the human hazard is developed, and an extensive experimental program is proposed.

United States of America (Continued)

- G/R.73 **MAXIMUM PERMISSIBLE RADIATION EXPOSURES TO MAN**
A preliminary statement of the U. S. National Committee on Radiation Protection and Measurement. The recommendations given by the Committee in NBS Handbook 59 have been revised and the maximum permissible dose-levels have been lowered. The concept of "accumulated" dose for occupational conditions differs from the ICRP recommendations of 1956. For the whole population an annual additional exposure of 2.5 times the exposure from natural radiation sources is allowed.
- G/R.74 **GONADAL DOSE PRODUCED BY THE MEDICAL USE OF X-RAYS**
A survey of diagnostic X-ray exposure with an attempt to estimate the genetically significant dose in the United States. The estimate has been made under the assumption that patients undergoing X-ray examinations have a normal child expectancy. The authors have assumed that the genetically significant dose can then be evaluated as approximately equal to the average gonad dose for patients below the age of 30. Using exposure data which are considered fairly representative of American practice they arrive at 130-140 mrem/year and 50 mrem/year as being the most probable and the minimum figure respectively.
- G/R.75 **SUMMARY OF CURRENT AND PROPOSED PROGRAMS OF RESEARCH IN THE U.S.A. RELATED TO RADIATION GENETICS**
A survey by investigator and title of current and proposed programs of research in the U.S.A. related to radiation genetics.
- G/R.91 **STRONTIUM-90 IN MAN**
Radiochemical analysis of Sr⁹⁰ in human bone have been reported. The values are in accord with the predicted levels based on fallout measurements and fractionation through the food chains.
- G/R.93 **SUMMARY OF ANALYTICAL RESULTS FROM THE HASL STRONTIUM PROGRAM JULY THROUGH DECEMBER 1956**
Summarizes data on samples collected by the U. S. A. fallout network since September 1955 up to September 1956. In addition, it summarizes the data of the samples collected for the strontium program during the period July to December 1956.
- G/R.94 **ENVIRONMENTAL RADON CONCENTRATIONS—AN INTERIM REPORT**
Preliminary data showing ambient concentrations of radon in the Metropolitan New York area are presented. An attempt has been made to define the variability of concentration of radon in the general atmosphere with location, time, and weather conditions. Samples have been analyzed from the outdoor air, inside of buildings, and above and below the surface of the ground. Comparisons with the data obtained by other investigators are also shown.
- G/R.95 **THE RADIUM CONTENT OF SOIL, WATER, FOOD, AND HUMANS—REPORTED VALUES**
- G/R.96 **MARINE BIOLOGY—EFFECTS OF RADIATION—A SELECTED BIBLIOGRAPHY**
24 references concerning investigation on the distribution and metabolism of fission products in marine organisms.
- G/R.97 **SEA DISPOSAL OPERATION**
Some atomic energy activities in the United States have been disposing of radioactive wastes at selected ocean disposal sites since as early as 1946. It is the purpose of this report to describe the extent of these disposal operations including a summary of types of packaging used and of places where the wastes are dumped. The status of related oceanographic research (1956) is briefly touched upon.

United States of America (Continued)

- G/R.97 Correction to the above report.
(Corr.1)
- G/R.108 **CURRENT RESEARCH FINDINGS ON RADIOACTIVE FALLOUT**
General survey of the fallout problem, especially Sr⁹⁰ distribution and uptake in the human body.
- G/R.109 **DOSAGES FROM NATURAL RADIOACTIVITY AND COSMIC RAYS**
- G/R.123 **RADIOACTIVITY OF PEOPLE AND FOODS**
Potassium and cesium activities measured with whole body counters are reported. The amount of Cs¹³⁷ now present in the population of the United States shows no marked dependence on geographical location.
- G/R.124 **ATMOSPHERIC RADIOACTIVITY ALONG THE 80TH MERIDIAN, 1956**
Radioactivity levels at the various sites during 1956 are reported for three different collecting systems: air filters, cloth screens, and gummed films. Extremely wide variations in the gross radioactivity of fission products in the air have been noted, with the highest levels occurring in the Northern hemisphere. Preliminary results of radiochemical analyses of a few filter collections are included.
- G/R.125 **RADIOACTIVE CONTAMINATION OF CERTAIN AREAS IN THE PACIFIC OCEAN FROM NUCLEAR TESTS**
Contains a summary of the data on contamination levels in some areas of the Pacific Ocean and results from medical surveys of Marshall Islands inhabitants. Data on gross beta activity, individual isotope contamination and external gamma exposure are included.
- G/R.130 **THE NATURE OF RADIOACTIVE FALLOUT AND ITS EFFECTS ON MAN**
An extremely diverse and extensive collection of information and expert opinion given as public testimony before a governmental committee, and presented without further evaluation.
- G/R.131 **RADIOACTIVE STRONTIUM FALLOUT**
General survey of the fallout problem, especially Sr⁹⁰ distribution and uptake in the human body.
- G/R.142 **RADIOACTIVE FALLOUT**
General survey of the fallout problem, especially Sr⁹⁰ distribution and uptake in the human body.
- G/R.153 **THE CHICAGO SUNSHINE METHOD: ABSOLUTE ASSAY OF STRONTIUM-90 IN BIOLOGICAL MATERIALS, SOILS, WATERS, AND AIR FILTERS**
Contains a survey of Chicago sunshine research program on the distribution of Sr⁹⁰ in the biosphere. Methods of sample treatment, counting, and evolution of date are reported. Detailed description of analytical chemical procedures is added.

World Health Organization

- G/R.58 **EFFECT OF RADIATION ON HUMAN HEREDITY—REPORT OF A STUDY GROUP (COPENHAGEN 7-11 AUGUST 1956)**
Document A. Reply to a question asked by the Scientific Committee on the Effects of Atomic Radiation. Report concerning general questions and recommendations for future progress and research.

World Health Organization (Continued)

- G/R.58 ANNEXES 1 AND 10 TO THE ABOVE DOCUMENT
(Add.1) 1. Damage from point mutations in relation to radiation dose and biological conditions.
- (1) Accumulation
 - (2) Linear relation to dose
 - (3) Influence of local concentration of activations
 - (4) Complications at high doses
 - (5) Influence of cell type on induced mutation rate
 - (6) Estimation of total damage from point mutations
 - (7) Manner of distribution and expression of the total damage
 - (8) The induced in relation to the spontaneous mutation damage
 - (9) Species differences and the problem of extrapolation
 - (10) Light from another source
10. Some problems in the estimation of spontaneous mutation rates in animals and man.

World Meteorological Organization

- G/R.35 SUMMARY OF COMMENTS OF WMO ON PROCEDURES FOR COLLECTION AND ANALYSIS OF ATMOSPHERIC RADIOACTIVITY DATA
Comments on measurements of fallout and airborne activity; stresses the importance of cooperation between meteorologists in selecting sites wherefrom to obtain samples.
- G/R.133 EXCERPT FROM A LETTER DATED 6 NOVEMBER 1957 RECEIVED FROM THE SECRETARY-GENERAL OF THE WMO-INTERIM INTERNATIONAL REFERENCE PRECIPITATION GAUGE
Brief report of the discussion held by the Executive Committee Panel on Atomic Energy and by the Commission for Instruments and Methods of Observations of the WMO on subjects related to the effects of atomic radiation.

NUMERICAL CROSS REFERENCE OF REPORT NUMBERS TO COUNTRIES

G/R.1 United States of America	G/R.53 Union of Soviet Socialist Republics
G/R.2 United Kingdom	G/R.54 United States of America
G/R.3 Belgium	G/R.55 United States of America
G/R.4 Japan	G/R.56 United States of America
G/R.5 Mexico	G/R.57 United States of America
G/R.6 Union of South Africa	G/R.58 World Health Organization
G/R.7 United States of America	G/R.58/Add. 1 World Health Organization
G/R.8 China	G/R.59 Netherlands
G/R.9 Canada	G/R.60 United Kingdom
G/R.10 Canada	G/R.60/Add. 1 United Kingdom
G/R.11 United States of America	G/R.61 Japan
G/R.12 Canada	G/R.61/Add. 1 Japan
G/R.13 New Zealand	G/R.62 Japan
G/R.14 Norway	G/R.63 Japan
G/R.15 Sweden	G/R.64 United States of America
G/R.16 France	G/R.65 United States of America
G/R.17 Czechoslovak Republic	G/R.66 United States of America
G/R.18 Korea	G/R.67 United States of America
G/R.19 Austria	G/R.68 United States of America
G/R.20 United Kingdom	G/R.69 Sweden
G/R.21 United States of America	G/R.70 Japan
G/R.22 United States of America	G/R.70/Corr. 1 Japan
G/R.23 Argentina	G/R.71 United States of America
G/R.24 United States of America	G/R.72 United States of America
G/R.25 Hungary	G/R.73 United States of America
G/R.26 Belgium	G/R.74 United States of America
G/R.27 Switzerland	G/R.75 United States of America
G/R.28 Argentina	G/R.76 Food and Agriculture Organization
G/R.29 Australia	G/R.76/Rev. 1 Food and Agriculture Organization
G/R.30 United Kingdom	G/R.77 Norway and Sweden
G/R.31 Federal Republic of Germany	G/R.78 Belgium
G/R.32 India	G/R.79 Sweden
G/R.33 India	G/R.80 Argentina
G/R.34 and G/R.34/Add. 1 Brazil	G/R.81 Argentina
G/R.35 World Meteorological Organization	G/R.81/Corr. 1 Argentina
G/R.36 Brazil	G/R.82 Argentina
G/R.37 Union of Soviet Socialist Republics	G/R.83 Argentina
G/R.38 Brazil	G/R.83/Add. 1 Argentina
G/R.39 Union of Soviet Socialist Republics	G/R.84 Argentina
G/R.40 Union of Soviet Socialist Republics	G/R.85 Argentina
G/R.41 Union of Soviet Socialist Republics	G/R.86 Argentina
G/R.42 Mexico	G/R.87 Argentina
G/R.43 Japan	G/R.88 Argentina
G/R.44 Japan	G/R.89 Argentina
G/R.45 Japan	G/R.90 Netherlands
G/R.46 Egypt	G/R.91 United States of America
G/R.47 Union of Soviet Socialist Republics	G/R.92 Norway
G/R.48 Union of Soviet Socialist Republics	G/R.93 United States of America
G/R.49 Union of Soviet Socialist Republics	G/R.94 United States of America
G/R.50 Union of Soviet Socialist Republics	G/R.95 United States of America
G/R.51 Union Kingdom	G/R.96 United States of America
G/R.52 Romania	

G/R.97 United States of America	G/R.141/Corr. 1 Japan
G/R.97/Corr. 1 United States of America	G/R.142 United States of America
G/R.98 Canada	G/R.143 United Kingdom
G/R.99 Canada	G/R.144 Norway
G/R.100 United Kingdom	G/R.145 Sweden
G/R.101 Denmark	G/R.146 Sweden
G/R.102 Austria	G/R.147 Sweden
G/R.103 United Kingdom	G/R.148 Sweden
G/R.104 United Kingdom	G/R.149 Sweden
G/R.105 United Kingdom	G/R.150 Sweden
G/R.106 Norway	G/R.151 Sweden
G/R.106/Add. 1 Norway	G/R.152 United Kingdom
G/R.107 New Zealand	G/R.153 United States of America
G/R.108 United States of America	G/R.154 Argentina
G/R.109 United States of America	G/R.155 Belgium
G/R.110 Netherlands	G/R.156 Belgium
G/R.111 Norway	G/R.157 Argentina
G/R.112 Norway	G/R.158 Belgium
G/R.113 Norway	G/R.159 Belgium
G/R.114 United Kingdom	G/R.160 U.S.S.R.
G/R.115 United Kingdom	G/R.161 Japan
G/R.116 Belgium	G/R.162 UNESCO/FAO/WHO
G/R.117 International Commission on Radiological Protection and International Commission on Radiological Units and Measurements	G/R.163 U.S.S.R.
	G/R.164 Mexico
	G/R.165 Food & Agriculture Organization of the United Nations
G/R.118 Poland	G/R.166 India
G/R.119 Belgium	G/R.167 United Kingdom
G/R.120 Belgium	G/R.168 Japan
G/R.121 Belgium	G/R.169 Brazil
G/R.122 Belgium	G/R.169/Corr. 1 Brazil
G/R.123 United States of America	G/R.170 United Kingdom
G/R.124 United States of America	G/R.171 United Kingdom
G/R.125 United States of America	G/R.172 Japan
G/R.126 United Kingdom	G/R.173 Sweden
G/R.127 Argentina	G/R.174 Sweden
G/R.128 United Kingdom	G/R.174/Add. 1 Sweden
G/R.129 Canada	G/R.174/Add. 2 Sweden
G/R.130 United States of America	G/R.175 Sweden
G/R.131 United States of America	G/R.175/Add. 1 Sweden
G/R.132 United Kingdom	G/R.175/Add. 2 Sweden
G/R.133 World Meteorological Organization	G/R.175/Add. 3 Sweden
G/R.134 Italy	G/R.175/Add. 4 Sweden
G/R.135 Japan	G/R.175/Add. 5 Sweden
G/R.136 Japan	G/R.175/Add. 6 Sweden
G/R.136/Corr. 1 Japan	G/R.175/Add. 7 Sweden
G/R.137 Japan	G/R.175/Add. 8 Sweden
G/R.138 Japan	G/R.175/Add. 9 Sweden
G/R.138/Corr. 1 Japan	G/R.176 Sweden
G/R.139 Japan	G/R.177 Sweden
G/R.139/Corr. 1 Japan	G/R.178 Sweden
G/R.140 Japan	G/R.179 France
G/R.140/Corr. 1 Japan	G/R.179/Corr. 1 France
G/R.141 Japan	G/R.180 France

G/R.181 Sweden	G/R.197 USSR
G/R.182 Sweden	G/R.198 USSR
G/R.183 The Netherlands	G/R.199 USSR
G/R.184 The Netherlands	G/R.200 USSR
G/R.184/Corr. 1 The Netherlands	G/R.201 USSR
G/R.185 New Zealand	G/R.202 USSR
G/R.186 France	G/R.203 USSR
G/R.187 Mexico	G/R.204 USSR
G/R.188 Brazil	G/R.205 USSR
G/R.189 Brazil	G/R.206 USSR
G/R.190 Brazil	G/R.207 USSR
G/R.191 United Arab Republic	G/R.208 USSR
G/R.192 United Arab Republic	G/R.209 Belgium
G/R.193 United Arab Republic	G/R.210 Belgium
G/R.194 France	G/R.211 France
G/R.195 Italy	G/R.212 France
G/R.196 USSR	G/R.213 France

Part 4

SELECTED PAPERS

THIS PAGE
WAS
INTENTIONALLY
LEFT BLANK
IN
ORIGINAL

THIS PAGE
WAS
INTENTIONALLY
LEFT BLANK
IN
ORIGINAL

RADIOSTRONTIUM IN SOIL, GRASS, MILK, AND BONE IN THE UNITED KINGDOM, 1956 RESULTS*

F. J. Bryant, A. C. Chamberlain, A. Morgan, and G. S. Spicer,
Atomic Energy Research Establishment, Harwell

ABSTRACT

The results of Sr^{90} analysis of soil, grass and sheep bone from twelve stations in England and Wales are given. The Sr^{90} in the top 4 inches of undisturbed soil in July, 1956 ranged from 1.9 to 10.0 mc/km^2 , depending on the rainfall. The Sr^{90} activity of herbage and of sheep bone showed a wider range, samples from acid hill soils being relatively more active. Milk from Somerset had a median activity of $4.4 \mu\text{mc}$ of Sr^{90} per gram of Ca in 1956, compared with 4.1 in 1955.

Human bone specimens obtained in 1956 showed Sr^{90} activity depending on age. The average level in children under 5 was $0.7 \mu\text{mc}$ of Sr^{90} per gram of Ca, and the average bone dose 2 mrad/year.

1 INTRODUCTION

The fission products formed in nuclear explosions are carried round the world in the upper air and fall to earth in rain (Eisenbud and Harley, 1953, 1955, 1956; Stewart et al., 1955, 1956; Libby, 1956). The fission product of greatest biological hazard is Sr^{90} (Medical Research Council, 1956, para. 236). The routes by which Sr^{90} enters the human body are shown diagrammatically in Fig. 1. The work described here is concerned with the Sr^{90} contamination of agricultural produce, and with the resulting trace contamination of human bones.

As strontium and calcium are chemically related the amount of Sr^{90} in biological materials is usually expressed in terms of the specific activity relative to calcium. The strontium unit, † or S.U. is defined as:

$$\text{Strontium unit} = 10^{-12} \text{ curie } \text{Sr}^{90} \text{ per gram calcium.}$$

2 METHODS

The analytical methods used have been described in detail in an AERE report (Bryant et al., 1956). After addition of carrier strontium, sample material is treated to bring the alkaline earths into solution. Radiostrontium (Sr^{89} and Sr^{90}) with the strontium carrier is separated from calcium as nitrate in strong nitric acid solution. Ferric hydroxide and barium chromate scavengers are included to remove contaminating activities. The separated strontium is stored with

*This paper was received from The Atomic Energy Research Establishment as Report A.E.R.E. HP/Ro 2353, dated August 1957.

†The unit was referred to in the past as the "Sunshine Unit."

yttrium carrier for at least 14 days and the yttrium precipitated as the hydroxide, converted to oxalate, mounted and counted in a suitable low background counter. The Y^{90} decay curve is followed and the activity of the Sr^{90} deduced. Strontium is also precipitated as carbonate, mounted and the Y^{90} allowed to re-equilibrate. The sample is counted and as the activity is then due to $Sr^{89} + Sr^{90} + Y^{90}$, the Sr^{89} activity can be deduced by difference. The count may be repeated at weekly intervals and the 54-day decay of the Sr^{89} observed.

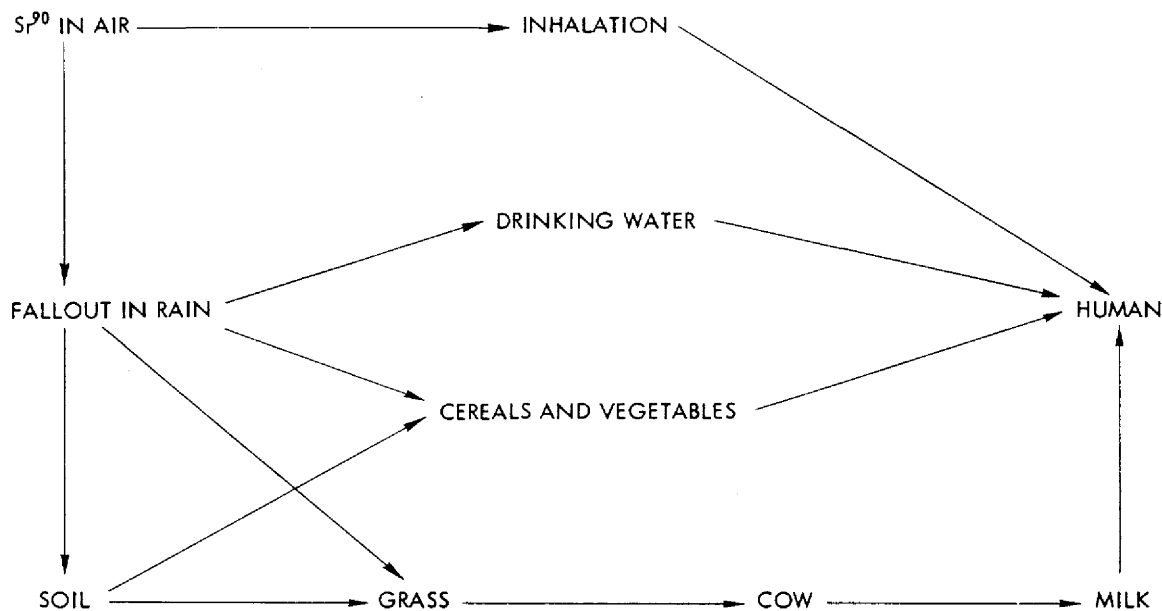

Fig. 1—Entry of Sr^{90} to human bone.

Typical decay curves from a sample of vegetation ash are shown in Fig. 2. In this instance the count rate of both Y^{90} and Sr^{89} was reasonably high, and an end window counter with background of 7 counts/min was used. When the specific activity of the original sample is low, or only a limited weight is available, very much lower counting rates are found. End window counters with a background of 0.5 counts/min (Bryant et al., 1956) are then used, but a 20-gram sample of human bone gives a maximum Sr^{90} activity of only a few disintegrations per minute and the Y^{90} measurement is often impracticable. The total strontium count is therefore reported for human bone. In instances where the activity has been sufficient for the Y^{90} determination, the Sr^{90} and total strontium counts have been compared and the Sr^{89}/Sr^{90} has been found to be low, as would be expected from the slow turnover of strontium in human bone. (Appendix 3).

The analytical methods used at AERE are generally similar to those developed at the University of Chicago by Libby and his associates (Libby, 1956; Martell, 1956) and at the Health and Safety Laboratory, USAEC, New York by Harley et al., (1956). Several intercomparison samples have been exchanged between different laboratories (Harley, 1956) and have shown good agreement.

There is a variation of practice in the treatment of soils, which is partly due to different objectives. The amount of calcium in the soil, which is removed by ion-exchange processes such as ammonium acetate leaching or the electrodialysis method used in the U.S., is variable as between one soil and another and depends also on the conditions of the extraction. The Sr^{90} in the soil appears to be mostly exchangeable. Consequently the Sr^{90}/Ca ratios or S.U. values in soils are usually higher when determined by ion exchange methods than when more complete extraction is made by hydrochloric acid leaching or fusion with sodium carbonate. The difference is most marked with calcareous soils.

The Sr^{90}/Ca ratio in the roots of plants growing in the soil is more nearly represented by the exchangeable than by the total strontium and calcium analysis, but it is very difficult to reproduce the extraction by the plant by any simple chemical procedure (Bowen & Dymond, 1955, 1956). Since the "exchangeable calcium" in the soil is an imprecise conception it was decided to make extraction with 6 M hydrochloric acid the standard procedure. Previous work (Bryant

et al., 1956) had shown that this method extracts as much Sr^{90} from the soil as the more heroic method of fusion with sodium carbonate, and it is shown below that measurements of the total Sr^{90} fallout by HCl extraction of soil agree well with the estimated cumulative fallout in rain.

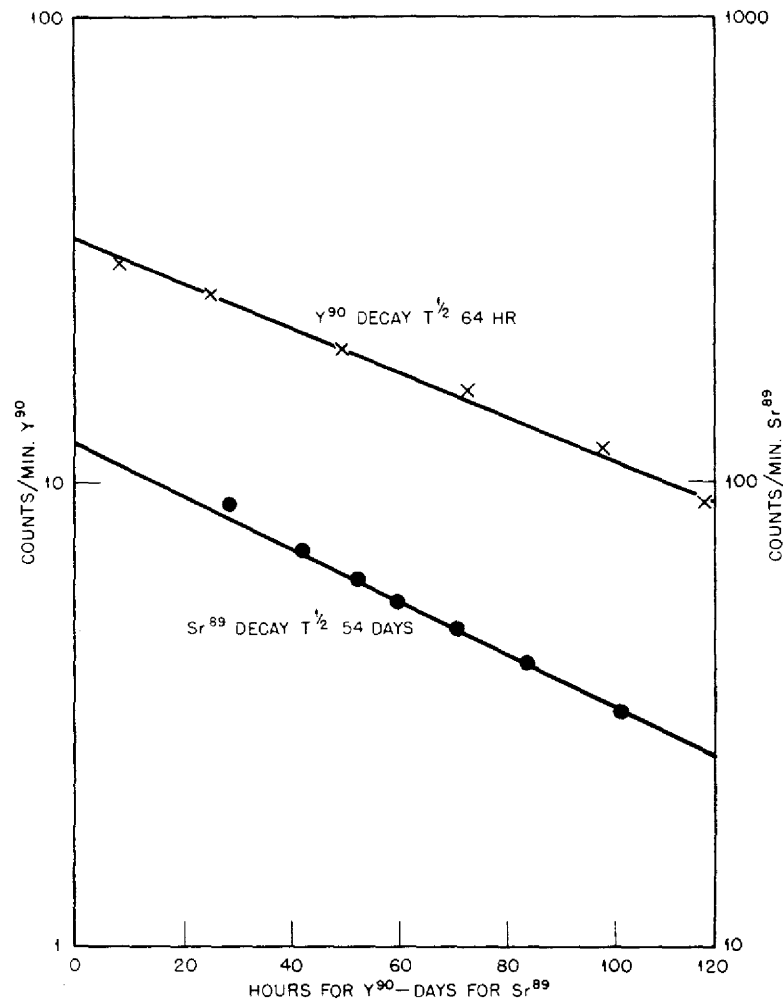

Fig. 2— Y^{90} and Sr^{89} decay.

Extraction with ammonium acetate at pH 7 as well as with HCl has also been done on a selection of soils, aliquots of dried, ground and mixed soil being taken for the two methods. The details are given by Bryant et al. (1956) for the 1955 soils and in Appendix 1 of this paper for the 1956 soils. In Fig. 3 the results in S.U. by the two methods are compared. On calcareous soils, which correspond to low S.U. values, there is considerable divergence between the HCl and NH_4Ac results, the latter tending to give higher S.U. ratios. On acid soils there does not seem to be any systematic difference in the S.U. results by the two methods.

There is also some variation of practice in the measurement of the Sr^{90} and Ca content of vegetation ash. Since the stable Sr content is low, Sr carrier is added before extraction with acid and the yield of Sr estimated. The Sr^{90} result is then corrected for yield, on the assumption that the stable and radioactive isotopes are extracted equally. This procedure is impossible for Ca, and in the method as described by Bryant et al., (1956) and used at Woolwich, an independent extraction of the ash with HF/HClO_4 is made for calcium determination.

In the Health Physics Division an alternative method has been used in which both Ca and Sr^{90} were determined in the $\text{HClO}_4/\text{HNO}_3$ extract, but it became clear from intercomparison of results (Appendix 2.1) that this extractant did not remove all the Ca from the ash.

A third method is being developed in which both Sr^{90} and Ca are determined in the HF/HClO_4 extract, and details of this method will be published later.

3 SAMPLING OF SOIL, GRASS AND SHEEP BONE

The analytical methods and counting techniques are lengthy and complicated so that the number of samples that can be analyzed in a year is limited. The sampling procedure had to be designed with the utmost economy of numbers, but it was decided nevertheless to include in the survey a wide range of climate and soil conditions. Soil and grass samples were confined to permanent grassland, so as to avoid the alterations in the soil activity profile brought about by cultivation.

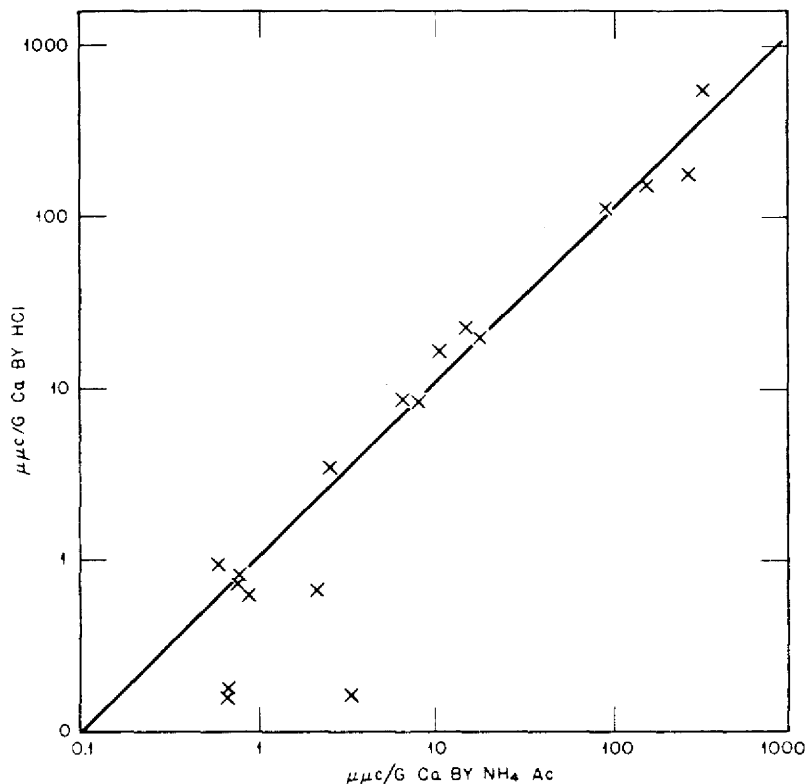

Fig. 3—Comparison of Sr^{90}/Ca ratios in soil by HCl and NH_4Ac extraction.

A list of sampling stations in use in 1956 is given in Table 1.

Stations A to G are farms carrying sheep on permanent pasture, A to E are hill farms, and F and G are lowland farms. One half-acre plot was selected for sampling on each station, except Station A, where two such plots were chosen. The plots were intended to be typical but not fully representative of the grazing, which on hill farms varies greatly from place to place.

Soil cores were taken in July 1956, from 10 or 12 points on each plot to a depth of 4 in. and a square yard of herbage surrounding each soil core was cut as closely as possible with shears. The sites had been grazed up to a few weeks before sampling, and the growth was therefore fresh. The soil and herbage sub-samples were bulked and mixed before analysis. Leg bones from a sheep between 12 and 15 months old, which had grazed pasture similar to and including the sampling plot for at least several months previously, were taken at each station. Yearlings were stipulated to ensure recent but mature bone growth.

To supplement the sheep stations, soil and grass were taken at five auxiliary stations. One of these (A3) is in the Cwmystwyth Valley, at Pwllpeiran, about 5 miles from the stations A1 and A2. The sampling area at A3 is in an upland valley, and is typical of the pastures to which the sheep are brought down in bad weather. The other four stations (H to K) are on former air-fields, all within 15 miles of Harwell, and having similar meteorological but dissimilar soil status. At these auxiliary stations, small plots of about 20 sq yd were fenced off. The soil cores and the herbage were taken from within these enclosed plots. At each of stations H to K in July, 1956, three cores were taken to depths 12 in., and divided into three horizons of 4 in. each to

Table 1—SAMPLING STATIONS

Ref.	Locality	Altitude ft	Rainfall 1954-1956		pH	Soil	
			in./yr	Total Ca, g/kg		Type	Samples
A1	Cwmystwyth, Cardigan	1200	60	4.3	0.14	Peat on shale	Soil, grass,
A2	Cwmystwyth, Cardigan	1100	60	4.5	0.17	(free draining)	sheep bone
A3	Cwmystwyth, Cardigan	800	60	4.9	1.0	Peat on shale	Soil, grass
						(free draining)	
B	Vyrnwy, Montgomery	1100	62	5.4	1.8	Peat on shale	Soil, grass,
						(free draining)	sheep bone
C	Talgarth, Brecon	1050	36	6.2	2.7	Free draining	Soil, sheep
						soil on sand-	bone
						stone	
D	Princetown, Devon	1300	81	5.6	5.8	Sandy peat	Soil, grass,
						on granite	sheep bone
E	Rookhope, Durham	1600	42	3.6	0.4	Peaty sandy	Soil, grass,
						loam with	sheep bone
						podsol layer	
F	Norwich, Norfolk	85	26	7.5	4.7	Sandy loam	Soil, grass,
						with gravel	sheep bone
G	Boxworth, Cambs.	157	22	6.8	14.6	Dark brown	Soil, grass,
						loam with	sheep bone
						chalk	
H	Aldermaston, Berks.	250	25	6.0	1.6	Sandy soil	Soil, grass
						with humus	
I	Culham, Oxon	180	22	6.6	3.0	Sandy soil	Soil, grass
						on lower	
						greensand	
J	Grove, Berks.	250	25	7.1	39	Heavy gault	Soil, grass
						clay	
K	Chilton, Berks.	400	24	8.0	156	Calcareous	Soil, grass
						clay with	
						flint	

test the penetration with depth. At A3 one single square yard soil sample only was taken in May, but when the sampling was repeated in November, twelve cores were taken.

At the five auxiliary stations, repeated samples of grass were taken at intervals from May to September 1956. Samples were of two types: (1) Accumulated growth taken from previously untouched plots; (2) Fresh grass which had grown since the last cutting.

4 RESULTS ON SOIL, GRASS AND SHEEP BONE

4.1 Sr⁹⁰ in Soil

A list of the results of Sr⁹⁰ analysis of soils taken in 1956 is given in Appendix 1, and a summary of the results by HCl extraction is given in columns 3 to 5 of Table 2. In Fig. 4 the Sr⁹⁰ activity by HCl extraction per unit area of soil to depth 4 in.* is compared with the annual rainfall at the same stations in the years 1954-1956. The line on the graph shows the fallout of Sr⁹⁰ which would have occurred if it is proportional to rainfall, using as reference point the cumulative total in rain of 5.6 mc/km² to July 1956, measured at Milford Haven, where the annual rainfall is 38 in. (Stewart et al., 1956, extended by further measurements). There is a rather large scatter in the results from the stations A1, A2 and A3, but otherwise there is good agreement between the fallout of Sr⁹⁰ believed to have occurred in rain, and that found in the top 4 in. of soil.

*The unit $\mu\text{c}/\text{m}^2$ is used in Table 2 and Appendix 1. The unit mc/km^2 , equivalent to $1000 \mu\text{c}/\text{m}^2$ is used in Fig. 4, because this unit is a commonly used measure of fallout generally.

Table 2—STRONTIUM-90 IN SOIL, GRASS, AND SHEEP BONE

Station	pH	Soil (HCl extraction)			Grass			Bone μμc/g Ca
		g Ca/kg	μμc/m ²	μμc/g Ca	μμc/m ²	μμc/kg	μμc/g Ca	
A1	4.3	0.14	4900	800	60	2550	2100	160
A2	4.5	0.17	5700	760	90	2500	1400	
A3	4.9	1.1	9600	130	15	230	116	
B	5.4	1.8	6600	59	145	1000	123	41
C	6.2	2.7	3300	14				24
D	5.6	5.8	10000	28	50	2100	125	53
E	3.6	0.37	5000	220	64	790	625	71
F	7.5	4.7	2900	5.2	20	450	64	13
G	6.8	14.6	3400	2.6	15	250	41	8.7
H	6.0	1.6	2600	19	a	24	150	68
					b	1.3	68	48
I	6.6	3.0	2500	8.0	a	24	100	33
					b	2.3	89	26
J	7.1	39	1900	0.66	a	18	100	32
					b	2.5	72	26
K	8.0	156	2200	0.15	a	27	190	33
					b	4.8	210	28

This agreement shows that Sr⁹⁰ remains substantially in the top soil and available to HCl extraction for periods of the order of years. This lack of penetration has previously been reported from the U.S. (Libby, 1956), and is shown also in the results from the 4 to 8 in. and 8 to 12 in. horizons from stations H to K, given in Appendix 1 and previously reported (Booker et al., 1957).

The soil results are also expressed as the specific activity of Sr⁹⁰ with respect to Ca (S.U.) in the extractant. The S.U. content of the soil is a function of the extractant used as well as the soil, especially for calcareous soils. On acid soils different methods of extraction appear to give approximately the same S.U. results (Fig. 3 and Bryant et al., 1956).

A more serious objection to the S.U. as a unit of Sr⁹⁰ in soil is that it takes no account of the vertical distribution of Sr⁹⁰ which may be very nonuniform even within the top 4 in. This is shown in the results from the two stations (D and E) where there was a sufficiently discrete layer of matt between vegetation and soil for a separate sample to be taken. The matt was found to contain about half the total activity in micromicrocurie per square meter, and the S.U. ratio in it was 4½ times that of the soil beneath. Equally sharp variation with depth may occur on other soils.

4.2 Sr⁹⁰ in Grass

The detailed results from the sheep stations are given in Appendix 2.1, and from the other stations in Appendices 2.2 to 2.6. A summary is given in Table 2, in which the figures quoted for stations A3 and H to K are the averages of the results on the sequential samples taken between May and September, 1956. At Stations H to K samples of accumulated growth and of new growth were taken separately, and the results on the two types are given in the rows labelled (a) and (b) respectively for each station.

The results are expressed in activity per square meter of ground, per kilogram dry weight and per gram Ca in the vegetation. The Sr⁹⁰ in micromicrocurie per square meter in vegetation may be compared with the corresponding figure for soil in the fourth column of Table 2, and the vegetation activity expressed as a percentage of that in the soil. This percentage varies from 2.2 at station B to 0.05 at station H (new growth).

The Sr⁹⁰ expressed in micromicrocurie per square meter in the new growth samples at stations H to K was only about one-sixth of that in the nearby samples of accumulated growth. This was largely due to the difference in the weight of vegetation. Per unit dry weight the accumulated growth had 17 per cent more Sr⁹⁰ than the new growth and per gram calcium 28 per cent more. Only the latter difference is significant on a test, and both are much smaller than

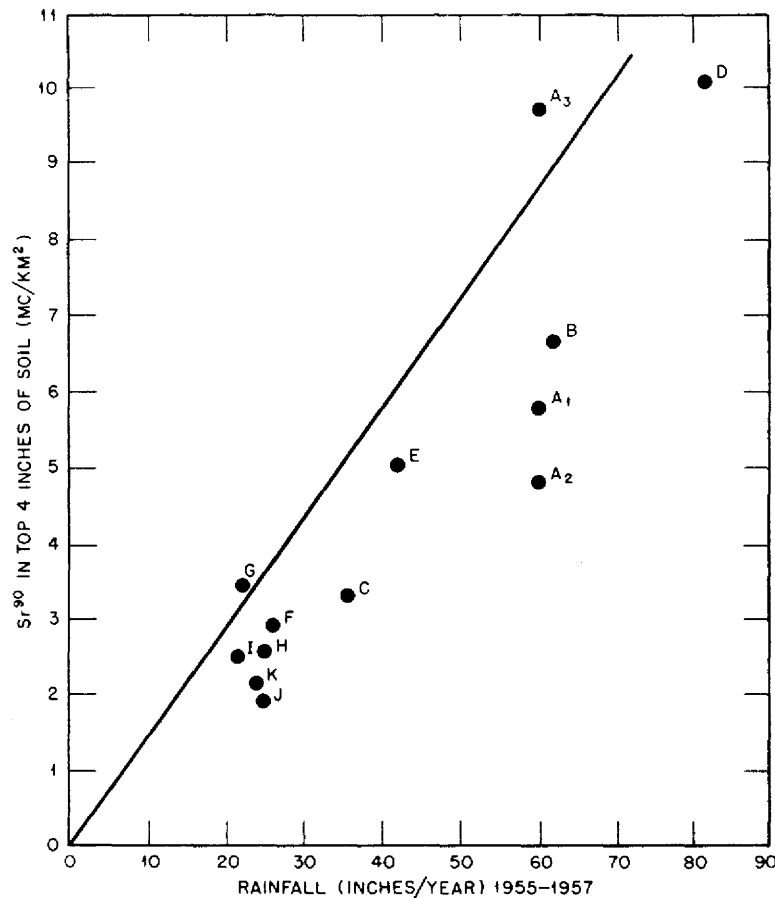

Fig. 4—Correlation of soil Sr⁹⁰ and rainfall.

the divergence between the micromicrocurie per square meter on adjacent new and old growth. This suggests that micromicrocurie per kilogram or micromicrocurie per gram of Ca is the best unit for expressing the activity of vegetation when the conditions of growth are uncontrolled.

In Fig. 5 the micromicrocurie per gram of Ca (S.U.) in vegetation at all stations in mid-1956 is correlated with the calcium content of the top 4 in. of soil. In making the comparison the variation in total fallout of Sr⁹⁰ ($\mu\mu\text{c}/\text{m}^2$ in soil) has been allowed for by normalizing the results of the various stations to a nominal fallout of 5000 $\mu\mu\text{c}/\text{m}^2$. Thus for station B, at which the Sr⁹⁰ in soil was 6600 $\mu\mu\text{c}/\text{m}^2$, the vegetation result given in Table 2 has been multiplied by the factor 5000/6600 before insertion in Fig. 5. The object of normalizing the results in this way is to avoid spurious correlation due to the association of high rainfall both with high total fallout and with low soil calcium and pH.

The normalized S.U. ratio in grass does not show any correlation with soil calcium when the latter is 1 g/kg dry weight or over, as determined by HCl extraction. Thus the normalized S.U. in grass from Pwllpeiran (A3) and from Chilton (K) are about the same, though the soil at the former station has 1 g of Ca per kilogram and pH 4.9 whereas the latter has 156 g of Ca per kilogram and pH 8.0.

The normalized S.U. values in vegetation on the uncultivated, acid, and very low calcium soils A1, A2 and E are higher by a factor of 10 to 60 than the values for normal soils.

Romney et al. (1957) grew crops in pots containing 7 different soils to which Sr⁹⁰ had been added. The highest Sr⁹⁰ levels were found in plants grown in acidic soils low in calcium and the lowest levels in the alkaline calcareous soils. Plants grown in the Sassafras soil, which had a pH of 4.6 and less than 0.1 g of exchangeable Ca per kilogram, took up about 10 times as much Sr⁹⁰ per unit dry weight as plants grown on alkaline calcareous soils. These experiments were under controlled laboratory conditions, using Sr⁹⁰ added uniformly to homogenized soil, and without the complications introduced by foliar uptake, the profile of Sr⁹⁰ in uncultivated soils, and the presence of peaty matt between vegetation and soil.

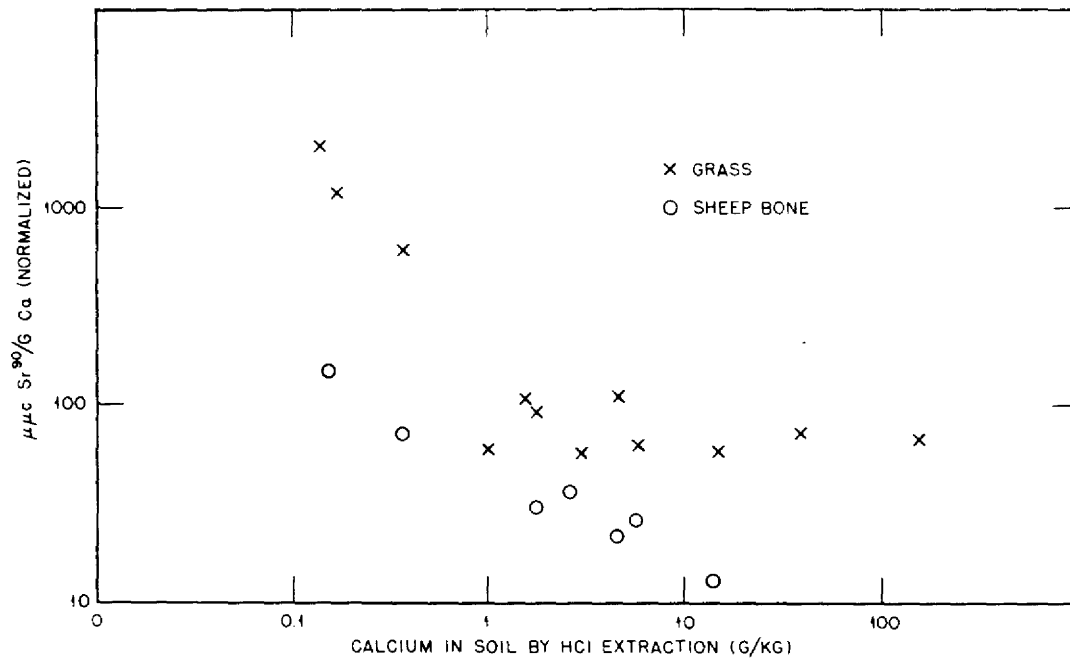

Fig. 5—Correlation of Sr⁹⁰ in grass and sheep bone with soil calcium (normalised to 5000 μμc/m² in soil).

4.3 Sr⁸⁹ in Grass

In the autumn of 1956 a series of measurements was made of the Sr⁸⁹/Sr⁹⁰ ratio in grass at Chilton, near Harwell. Grass samples (accumulated growth) were taken at monthly intervals and rain was also collected during the month previous to each grass sample. The Sr⁸⁹ and Sr⁹⁰ activities were measured, and the Sr⁸⁹/Sr⁹⁰ ratio at the time of sampling worked out. These results are shown in Table 3. The Sr⁸⁹/Sr⁹⁰ ratio in the soil was also estimated, by numerical integration of the monthly fallout of Sr⁸⁹ and Sr⁹⁰.*

Table 3—Sr⁸⁹/Sr⁹⁰ RATIOS IN GRASS, RAIN, AND SOIL AT CHILTON

Date	Sr ⁸⁹ /Sr ⁹⁰ ratio		
	Grass	Rain	Soil
Oct. 5, 1956	22	40	2.4
Dec. 3, 1956	15	28	2.2
Jan. 1, 1957	10	19	2.3
Feb. 1, 1957	13	17	2.3
Mar. 1, 1957	12	15	2.1

The Sr⁸⁹/Sr⁹⁰ ratio in rain decreased from 40:1 to 15:1 during the period of these measurements but the calculated soil ratio declined only from 2.4:1 to 2.1:1, because of the effect of build-up and radioactive decay. The Sr⁸⁹/Sr⁹⁰ ratio in grass was on each occasion intermediate between that of rain and of soil.

*For this purpose results on the Sr⁸⁹ and Sr⁹⁰ content of rain at Milford Haven due to Osmond (1957) were used. This was necessary because the Chilton results did not extend far enough back. Over the period during which the Sr⁸⁹/Sr⁹⁰ ratio from both stations was available, there was good agreement between them.

4.4 Sr⁹⁰ in Sheep Bone

The Sr⁹⁰ in calcium ratio in the bones of yearling sheep at stations A to G are shown in Table 2, and the normalized S.U. values are plotted against soil calcium in Fig. 5. Independent estimations by different laboratories on mixed ash samples show reasonable agreement, but there is an unknown variation between animals from the same flock.

The range of results for sheep from different areas in 1956 is as follows:*

	No.	Range (S.U.)	Median (S.U.)
Lowland sheep	7	7.8 to 15.6	14
Hill sheep	6	24 to 160	57

The hills grazed by sheep in Britain are generally areas of high rainfall. The soil is uncultivated, peaty and of low calcium status and there is low yield of vegetation. Any or all these factors may tend to enhance the uptake of Sr⁹⁰. The lowland farms generally have the opposite conditions. It is not possible to deduce from the present results the relative importance of these factors, but it is clear, from Fig. 5 that variation in the total fallout of Sr⁹⁰ is not the sole cause. The bones of hill sheep contain more Sr⁹⁰ per unit fallout than those of lowland sheep.

4.5 Ratio of Strontium to Calcium in Herbage and Sheep Bone

In Table 4 the Sr/Ca and Sr⁹⁰/Ca ratios in grass and sheep bone at stations A to G are compared. The estimations of stable Sr were made by the Spectrographic Section, Chemistry Division (Woolwich Outstation) using methods which will be reported separately. The discrimination against Sr in passage from grass to bone is shown with both stable and radioactive Sr. Following Comar et al. (1956, 1957), the "Observed Ratio" (OR) is defined as:

$$OR_{\text{bone-grass}} = \frac{\text{Sr/Ca in bone}}{\text{Sr/Ca in grass}}$$

The OR for the sheep-bone/grass comparison varies between 0.15 and 0.31 for stable Sr, and between 0.09 and 0.42 for Sr⁹⁰. The mean of the OR's at the various stations is 0.24 (stable) and 0.23 (radioactive). These values are in excellent agreement with results reported elsewhere with various animal species (Comar et al., 1957).

Table 4—STRONTIUM/CALCIUM RATIOS IN GRASS AND SHEEP BONE

Station	Stable Sr, $\mu\text{g/g Ca}$			Sr ⁹⁰ , $\mu\mu\text{c/g Ca}$		
	Bone	Grass	OR	Bone	Grass	OR
A	730	5000	0.15	160	1750	0.09
B	470	1500	0.31	41	123	0.33
D	470	1700	0.28	53	125	0.42
E	650	2800	0.23	71	625	0.14
F	520	2500	0.21	12.8	64	0.20
G	930	3400	0.27	8.7	41	0.21
Average			0.24			0.23

5 RADIOSTRONTIUM IN MILK

A series of samples of spray dried skimmed milk from a factory at Frome, Somerset† have been analyzed, some in New York (by the kindness of Dr. J. H. Harley) and some at Wool-

*Some additional bones from animals killed in the early part of 1956, reported by Bryant et al. (1956) have been included.

†The location was wrongly referred to as Yeovill by Bryant et al., 1956.

wich and Harwell. The results are shown in Fig. 6 together with the cumulative Sr⁹⁰ fallout in rain at Milford Haven, reported by Stewart et al. (1956).

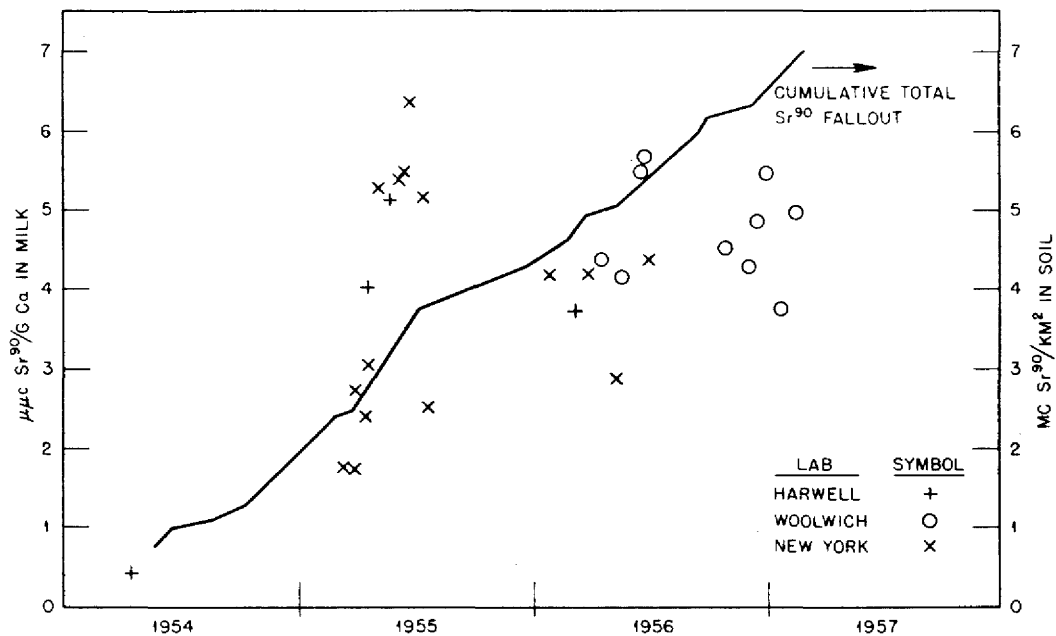

Fig. 6—Sr⁹⁰ in Somerset milk.

A comparison of the milk activity with the total fallout shows that, whereas the latter has increased fairly steadily for the past three years, the former rose quickly from about 2 to 5 S.U. in the spring of 1955 and has thereafter stayed fairly constant. The median of thirteen 1956 samples is 4.4 S.U., compared with 4.1 S.U. in 1955. The general trend is consistent with the theory that the milk activity is determined partly by the cumulative fallout and partly by the rate of fallout.

In October and again in December 1956, samples of dried milk from various parts of Britain were obtained, and Sr⁸⁹ and Sr⁹⁰ determinations made, with results shown in Table 5. There is

Table 5—REGIONAL COMPARISON OF Sr⁹⁰ AND Sr⁸⁹ IN DRIED MILK

Area	Date of manufacture, 1956	Sr, μg/g Ca	Sr ⁹⁰ , μμc/g Ca	Sr ⁸⁹ , μμc/g Ca	Ratio Sr ⁸⁹ /Sr ⁹⁰
Carmarthen	Oct. 17		8.0	190	23
Carmarthen	Dec. 29	200	7.2	30	4.2
Yorkshire	Oct. 16		4.3	53	12
Yorkshire	Dec. 27	240	3.9	19	4.8
Cumberland	Oct. 19		6.5	100	15
Cumberland	Dec. 25	410	5.6	5	0.8
Antrim	Oct. 19		6.9	150	22
Antrim	Dec. 28	270	7.0	24	3.4
Londonderry	Oct. 17		10.3	220	21
Londonderry	Dec. 27	280	6.2	22	3.6
Somerset	Oct. 26		4.6	110	24
Somerset	Dec. 28	230	5.5	25	4.5

a tendency in both sampling periods for the Sr⁹⁰ activity to be higher in milk from the North and West of the British Isles than in that from the South and East. This is probably an effect of rainfall amounts. The activity of just over 10 S.U. found in the October sample from Londonderry, Northern Ireland compares with maxima of 10 S.U. or slightly more, reported from

British Columbia (Atomic Energy of Canada Limited, 1957) and from North Dakota (Harley et al., 1956).

The $\text{Sr}^{89}/\text{Sr}^{90}$ ratio in the October milk samples varies from 12 (Yorkshire) to 24 (Somerset), which compares with a ratio of 22 found in Chilton grass (Table 3). There is a marked reduction in Sr^{89} activity from the October to the December 1956 sampling, due mainly to the change over from fresh grass eaten by the cows in the open autumn of 1956 to hay, silage, and other stored foods in winter time. If the cows were eating in December hay or silage cut the previous June, the Sr^{89} content would have experienced a radioactive decay of three half lives, reducing it by a factor 8, during the storage period.

The stable Sr/Ca ratios in the December series of samples were measured spectrographically, and show a range from 200 to 410 micrograms Sr per gram Ca.

6 RELATIVE IMPORTANCE OF MILK AND OTHER SOURCES OF Sr^{90}

Milk is the main source of calcium for growing children in Britain but it does not necessarily follow that it is the main source of strontium or of radiostrontium. Strontium-90 reaches the earth in air and rain, neither of which contains appreciable calcium, and it is therefore possible for Sr^{90} to enter the human body by routes different from those of calcium. Some possible alternatives are considered in turn.

6.1 Inhalation

Stewart et al. (1956) give the mean Sr^{90} concentration in air at ground level in the years 1952-1955 as $4 \times 10^{-16} \mu\text{c}/\text{cc}$. A person breathing at the "standard man" rate of $20 \text{ m}^3/\text{day}$ would have inhaled $10 \mu\mu\text{c}$ in the four years. Taking the fraction transferred to bone as 0.22 (ICRP, 1955), the resulting body burden would be 0.002 S.U. The same calculation would apply to a child, except insofar as the breathing rate of an active child may be greater in proportion to its body weight. Inhalation cannot therefore be a major factor in determining the body burden of Sr^{90} .

6.2 Drinking Water

The mean Sr^{90} content of rain in 1952-1955 was $1.7 \mu\mu\text{c}/\text{litre}$. (Stewart et al., 1956). In 1956 it was about $2.5 \mu\mu\text{c}/\text{litre}$. A litre of liquid milk contains about 1 gram of Ca, so the figures quoted above for the S.U. content of milk can also be read as $\mu\mu\text{c}/\text{litre}$. The Sr^{90} content of milk is thus about twice that of rain water, volume for volume.

6.3 Cereals and Vegetables

If the plants eaten by man have S.U. levels equal to those found in grass they are potentially an important source of Sr^{90} , since they enter into diet without the discrimination against strontium which occurs in the production of milk by cows. Adequate data are lacking, but there are indications that the Sr^{90} levels in cereals and vegetables in Britain are at present about the same as in milk, and considerably lower than in grass.* The reasons for this include the effects of cultivation and the protection afforded against foliar uptake by the outer leaves and husks of vegetables and cereals, and by washing and other preparatory processes. The addition of mineral calcium will depress the S.U. ratio in flour.

The relative importance of milk and other sources of Sr^{90} may change with time, as the importance of foliar uptake and of the effect of cultivation will lessen as the cumulative fallout increases and the Sr^{90} becomes more evenly distributed in the top soil.

*Hiyama (1957) has reported that brown rice samples in Japan gave 12 S.U. in July 1956, and 104 S.U. in November 1956. There is some doubt whether the latter estimate is of Sr^{90} or of Sr^{90} and Sr^{89} . Since the $\text{Sr}^{89}/\text{Sr}^{90}$ ratio in grass towards the end of 1956 was about 20:1, the distinction is an important one.

7 RADIOSTRONTIUM IN HUMAN BONES

A list of human bone specimens to the end of 1956 analyzed at Woolwich is given in Appendix 3, and the radiostrontium results* on 34 femora and 3 tibiae among them are shown in Fig. 7. The specimens come mostly from South East England and the Midlands, but there were a few from the West and Northwest, and these included the two showing the highest radiostrontium activity, namely, 1.55 S.U. in a two-year-old Plymouth child and 1.3 S.U. in a three-month-old child from Carlisle.† There is a considerable scatter in the results on bones from infants under 1 year, but thereafter there is a fall off in the Sr^{90}/Ca ratio with age.

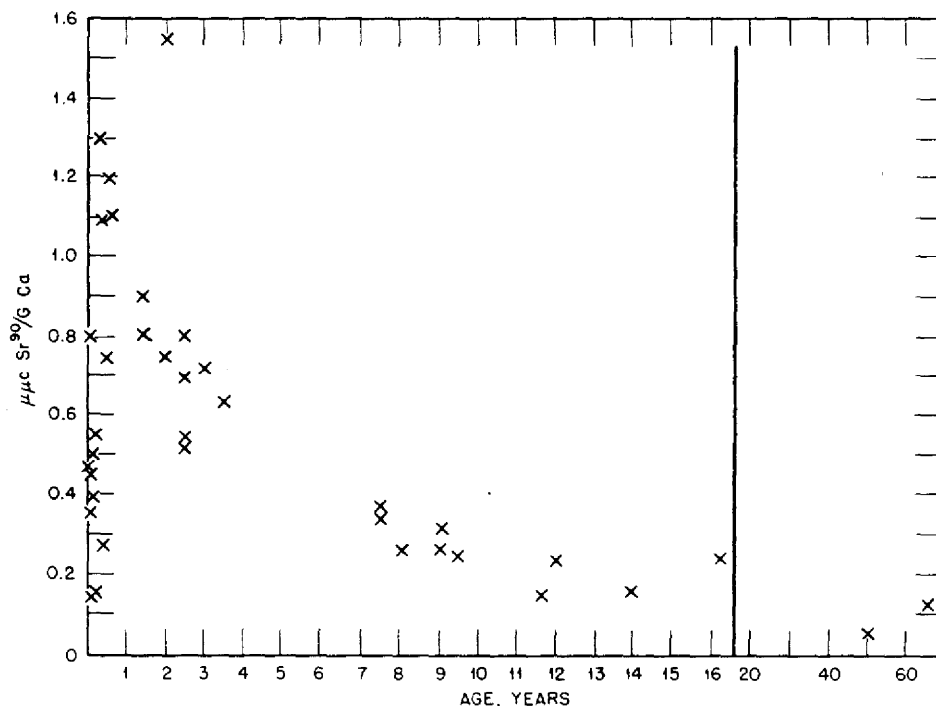

Fig. 7— Sr^{90} in human bone in 1956.

The average Sr^{90} activity of femora in various age groups is given in Table 8 at the end of this paper.

As the minimum weight of bone for a reasonably accurate Sr^{90} estimation is 50 g, it was not possible to make a detailed study of distribution within the bone, but two femora from older children were each divided into four portions which were analyzed separately as shown in Table 6. The pattern is the same in both specimens, with a maximum in the new sub-epiphyseal bone and a minimum in the old bone in the centre of the shaft.

Stable Sr measurements have been made on a number of human bones, and the results are given in Appendix 3. The average at all ages in the present series is 290 μg of Sr per gram of Ca, which is not significantly different from the average of 270 μg of Sr per gram of Ca found in milk. Since, however, the stable Sr content of foods not derived from milk is about 10 times greater than this, it is by no means certain that milk is the main source of stable Sr in human bone.

*As stated in the paragraph on methods, the practice with human bones has been to measure the total radiostrontium activity and attribute it to Sr^{90} . On specimens for which Y^{90} has been measured independently, the Sr^{90} activity deduced has been within 15 per cent of that estimated by the total strontium method.

† Provisional results of 2.3 S.U. in a one-year-old Cumberland child and 2.4 S.U. in a six-month-old Liverpool child have been obtained in 1957.

Table 6—DISTRIBUTION OF Sr⁹⁰ IN HUMAN FEMORA
($\mu\mu\text{c/g Ca}$)

Reference	HB 38	HB 57
Age (years)	14	9
Distal epiphyseal plate	0.17	0.25
Distal sub-epiphyseal bone	0.20	0.34
Centre of shaft	0.11	0.22
Proximal sub-epiphyseal bone	0.20	0.27

8 DOSE RATE FROM RADIOSTRONTIUM

In Table 7 the average dose rate to bone from the Sr⁹⁰ burden in children in 1956 is compared with that due to natural radioactivity (Spiers, 1956).

Table 7—DOSE RATE FROM Sr⁹⁰ AND NATURAL RADIOACTIVITY TO BONE

Source of Radiation	Dose rate, mrem/yr
Natural radiation	
External sources	82
Radium in bone	39
Total	121
Sr ⁹⁰ in children under 5 in 1956	
Median level (0.70 S.U.)	2
Maximum level (1.55 S.U.)	4

The highest Sr⁹⁰ activity recorded in 1956 gives an average dose to bone which is one-tenth of that due to the natural radium, when allowance is made for the relative biological efficiency of the alpha rays,* and one thirtieth of the total natural dose to bone from internal and external sources.

9 MAXIMUM PERMISSIBLE BODY BURDEN OF Sr⁹⁰

The maximum permissible body burden for occupational workers is one microcurie (ICRP, 1955) which is approximately equivalent to 1000 S.U. The Medical Research Council Committee (1956) have proposed a limit of one-tenth of the occupational body burden for the general population, and state also that "immediate consideration would be required if the concentration in human bones showed signs of rising greatly beyond one-hundredth of that corresponding to the maximum permissible occupational level."

The highest Sr⁹⁰ activity in human bone found in our series to the end of 1956 is 1.55 S.U. which is $\frac{1}{60}$ of the maximum permissible for the general population, and $\frac{1}{6}$ of the level above which "immediate consideration would be required."

It has been suggested that a dose rate 10 times the human occupational level would be acceptable for animals (Chamberlain, Loutit, Scott Russell and Martin, 1956). The Sr⁹⁰ maximum permissible level for sheep would then be 10,000 S.U. The highest levels recorded in Britain are at Cmmystwyth, when 183 S.U. was found in October, 1955 (Bryant et al., 1956) and 160 S.U. in July 1956 (Table 2).

*RBE of alpha rays is 10 (ICRP, 1955).

10 SUMMARY OF 1956 RESULTS

The range of 1956 results on the various materials sampled and the median values are given in Table 8.

Table 8—Sr⁹⁰ IN BIOLOGICAL MATERIALS IN 1956

Material	No. of samples	Sr ⁹⁰ activity, $\mu\mu\text{c/g}$ of Ca		
		Max.	Min.	Median
Grass (acid hill soils)	9	2100	91	130
Grass (normal soils)	61	77	11	37
Sheep bones (hills)	6	170	24	57
Sheep bones (lowland)	7	15.6	7.8	13.7
Milk (Somerset)	13	5.7	2.9	4.4
Milk (other areas)	10	10.3	3.9	6.7
Human bones (femora and tibiae)				
0-5 years	25	1.55	0.15	0.70
5-20	10	0.38	0.15	0.26
>20	2	0.13	0.06	

11 ACKNOWLEDGMENTS

We are indebted to K. H. Jones and to all members of the National Agricultural Advisory Service of the Ministry of Agriculture, Fisheries and Food who obtained samples for us. Dr. Rice Williams, in particular, gave very valuable advice and practical help in obtaining the Welsh samples.

We are indebted to Dr. M. Bodian, Dr. J. S. Faulds, Dr. R. H. Mole, Dr. A. H. Cameron and Dr. C. A. Jones who went to great trouble to provide the human bone specimens, to Dr. J. F. Loutit, Dr. E. E. Pochin and Dr. R. Scott Russell for helpful discussions.

Appendix 1—LIST OF SOIL SAMPLES
(Soil samples to depth 4 inches except where otherwise stated)

Station	Ref.	Sample		Soil		Sr ⁹⁰		Method
		Date, 1956	No. of cores	kg/m ²	g of Ca/kg	μμc/g of Ca	μμc/m ²	
A1	A31	May 7	1	50	0.13	520	3400	HCl
					0.11	330	1800	NH ₄ Ac
A1	A48	July 9	10	37	0.09	1440	4800	HCl
A1	A46	Oct. 20	12	45	0.19	680	5700	HCl
					0.20	800	7200	HCl
A1	Mean			44	0.14	800	4900	HCl
A2	A42	July 9	10	44	0.17	760	5700	HCl
A3	A30	May 7	1	79	1.11	110	9700	HCl
					1.04	110	8900	HCl
					0.65	98	4900	NH ₄ Ac
A3	A47	Nov. 20	12	66	0.97	150	10000	HCl
B	A43	July 6	10	62	1.8	59	6600	HCl
C	A23	Mar. 20	10	86	2.7	14	3300	HCl
D	A40	July 18	10	57	5.5	19	5900	HCl
	(matt)	July 18		5.4	8.7	88	4100	HCl
	(total)	July 18		62	5.8	28	10000	HCl
E	A41	July 10	12	59	0.31	120	2200	HCl
	(matt)	July 10		5.3	1.0	560	3000	HCl
	(total)	July 10		64	0.37	220	5200	HCl
F	A33	July 4	16	119	4.7	5.2	2900	HCl
G	A32	July 3	12	90	14.6	2.6	3400	HCl
H	A36	July 31	3	86	1.6	19	2600	HCl
		July 31			1.4	17	2000	NH ₄ Ac
	4-8"	July 31	3	107	1.5	<0.8	<150	HCl
	8-12"	July 31	3	128	1.5	<0.3	<150	HCl
I	A37	July 31	3	104	3.0	8.0	2500	HCl
		July 31			2.3	8.5	2000	NH ₄ Ac
	4-8"	July 31	3	128	2.7	0.6	200	HCl
	8-12"	July 31	3	131	3.5	<0.3	<150	HCl
J	A35	July 27	3	75	39	0.66	1900	HCl
		July 27	3		7.7	2.2	1300	NH ₄ Ac
	4-8"	July 27	3	87	17	0.18	270	HCl
	8-12"	July 27	3	107	9.5	0.22	220	HCl
K	A38	July 27	3	96	156	0.15	2200	HCl
		July 27	3		6.6	3.4	2200	NH ₄ Ac
	4-8"	July 27	3	132	185	<0.01	<150	HCl
	8-12"	July 27	3	158	204	<0.01	<150	HCl

Appendix 2—LIST OF GRASS SAMPLES

Ref.	Station	Date, 1956	Dry wt., g/m ²	Ca, g/kg	Sr, µg/g of Ca	Sr ⁹⁰				Lab
						µµc/m ²	µµc/kg	µµc/g of Ca	µc/g of Sr	
A.2.1 Sr ⁹⁰ IN GRASS ON SHEEP FARMS										
D51	A1	July 9	23	1.5	5000	64	2700	1900	0.38	W
	A1	July 9	23	1.1		57	2400	2200		H
D69	A2	July 9	37	2.0		100	2800	1400		W
		July 9	37	1.6		80	2200	1400		H
D45	E	July 6	151	8.2	1500	160	1100	134	0.089	W
		July 6	151	7.7		130	870	112		H
D65	D	July 18	24	17.3	1700	58	2400	140	0.082	W
		July 18	24	15.6		42	1800	110		H
D44	E	July 10	81	1.5	2800	77	950	650	0.23	W
		July 10	81	1.0		51	630	600		H
D38	F	July 4	45	7.1	2500	20	450	64	0.026	W
D37	G	July 3	60	6.3		15	250	41		W
A.2.2 Sr ⁹⁰ IN GRASS AT PWLLPEIRAN, CWMYSTWYTH (STATION A3)										
D32	A3	June 18	53	1.9		13	240	126		
D39	A3	July 3	105	1.1		14	130	124		
D57	A3	Aug. 8	64	2.0		12	180	91		
D68	A3	July 17	61	3.0		22	365	121		
		Average	71	2.0		15	229	116		

Appendix 2—(Continued)

Ref.	Date, 1956	Growth	Dry wt., g/m ²	Ca, g/kg	Sr ⁹⁰			
					μμc/m ²	μμc/kg	μμc/g of Ca	
A.2.3 Sr ⁹⁰ IN GRASS AT ALDERMASTON (STATION H)								
D27/2	May 29	(a)	109	1.6	7.3	67	42	
27/3	May 29	(a)	203	1.9	18.5	91	49	
27/4	May 29	(a)	148	1.8	7.2	49	27	
27/5	May 29	(a)	154	1.5	9.9	64	43	
Mean	May 29	(a)	153	1.7	10.7	68	40	
D35/5	June 19	(a)	207	1.5	23.8	115	77	
D35/1-4	June 19	(b)	15	1.3	1.5	100	77	
D41/5	July 10	(a)	189	1.0	11.9	63	63	
D41/1-4	July 10	(b)	27	1.6	1.9	70	44	
D48	July 31		Samples lost in analysis					
D55/5	Aug. 23	(a)	144	4.1	37	260	63	
D55/1-4	Aug. 23	(b)	19	1.4	0.6	34	24	
Mean		(a)	180	2.2	24	146	68	
		(b)	20	1.4	1.3	68	48	
A.2.4 Sr ⁹⁰ IN GRASS AT CULHAM (STATION I)								
D24/1	May 8	(a)	135	4.2	23	170	40	
24/2	May 8	(a)	154	4.4	22	145	33	
24/4	May 8	(a)	183	4.7	44	240	51	
24/5	May 8	(a)	120	5.2	23	190	37	
Mean	May 8	(a)	148	4.6	28	186	40	
D29/5	May 29	(a)	147	3.5	20	135	39	
D29/1-4	May 29	(b)	17	3.8	2.3	140	36	
D34/5	June 19	(a)	303	2.9	24	78	27	
D34/1-4	June 19	(b)	28	4.2	1.3	46	11	
D43/5	July 10	(a)	303	3.3	44	145	44	
D43/1-4	July 10	(b)	37	4.3	4.1	110	26	
D45/5	July 31	(a)	106	2.4	5.6	53	22	
D46/1-4	July 31	(b)	23	1.9	1.4	60	32	
Mean		(a)	215	3.0	24	103	33	
		(b)	26	3.5	2.3	89	26	
A.2.5 Sr ⁹⁰ IN GRASS AT GROVE (STATION J)								
D23/1	May 8	(a)	106	1.6		Lost		
23/2	May 8	(a)	61	1.8	4.6	75	42	
23/3	May 8	(a)	59	1.8	3.7	63	35	
23/4	May 8	(a)	75	1.8	5.2	70	39	
23/5	May 8	(a)	63	1.9	2.7	44	23	
Mean	May 8	(a)	64	1.8	4.0	63	35	
D28/5	May 29	(a)	96	2.7	7.0	73	27	
D28/1-4	May 29	(b)	42	2.1	2.3	55	26	
D35/5	June 19	(a)	170	4.2	27.7	164	39	
D33/1-4	June 19	(b)	36	2.6	2.6	73	28	
D42/5	July 10	(a)	259	2.7	20.5	78	29	
D42/1-4	July 10	(b)	25	3.8	2.5	88	23	
D49	July 31		Samples lost in analysis.					
Mean		(a)	175	3.2	18.4	105	32	
		(b)	39	2.8	2.5	72	26	

(a) Accumulated growth.

(b) New growth since cutting 3 weeks previously.

Appendix 2—(Continued)

A.2.6 Sr⁹⁰ IN GRASS IN CHILTON (STATION K)

Ref.	Date, 1956	Growth	Dry wt., g/m ²	Ca, g/kg	Sr ⁹⁰			Sr ⁸⁹ /Sr ⁹⁰ , ratio
					μμc/m ²	μμc/kg	μμc/g of Ca	
D25/1	May 9	(a)	78	5.0	14	180	36	
25/2	May 9	(a)	63	7.6	18	290	38	
25/3	May 9	(a)	105	5.5	20	180	33	
25/4	May 9	(a)	120	4.2	27	230	55	
25/5	May 9	(a)	76	3.2	10	130	40	
Mean		(a)	88	5.1	18	200	40	
D30/5	May 30	(a)	177	3.7	26	145	39	
D30/1-4	May 30	(b)	19	3.8	2.4	130	34	
D36/5	May 20	(a)	185	3.7	21	115	31	
D36/1-4	May 20	(b)	34	3.4	4.4	130	37	
D40/5	July 11	(a)	187	5.2	32	170	33	
D40/1-4	July 11	(b)	31	9.2	7.1	240	25	
D47/5	Aug. 1	(a)	120	7.1	29	240	34	
D47/1-4	Aug. 11	(b)	16	13.5	2.9	210	16	
D54/5	Sept. 9	(a)	97	9.0	26	260	29	
D54/1-4	Sept. 9	(b)	22	11.5	7.1	320	28	
Mean		(a)	153	5.7	27	186	33	
		(b)	24	8.3	4.8	206	28	
D64	Oct. 5	(a)	234	6.2	57	243	39	22
D76	Dec. 3	(a)	182	8.5	66	364	42	15
D81	1/1/57	(a)	144	8.3	66	458	54	10
D92	2/1/57	(a)	114	13.4	63	552	41	13
D104	3/1/57	(a)	74	9.8	56	760	77	12

(a) Accumulated growth.

(b) New growth since cutting 3 weeks previously.

Appendix 3—LIST OF HUMAN BONE SAMPLES

Ref.	Month	Age at Death	Bone	District	Sr, μg/g Ca	Sr ⁹⁰ , μμc/g of Ca	
						(a)	(b)
1955							
HB1	Oct.	12	Ribs	Swindon		0.2	
2	Oct.	27	Ribs	Swindon	330	0.15	
3	Oct.	40	Ribs	Swindon	380	0.05	
4	Oct.	38	Ribs	Reading	350	0.05	
5	Oct.	6	Ribs	Swindon		0.15	
6	Dec.	1		Birmingham		1.2	
7	Nov.	27		Reading		0.2	
8	Dec.	31	Ribs	Oxford		0.06	
9	Nov.	23	Ribs	Reading		0.16	
10	Dec.	10	Ribs	Birmingham		0.57	0.50
1956							
11	Jan.	1½ yr	Ribs	Birmingham		0.76	
12	Jan.	1 yr	Ribs	Birmingham		1.1	1.1
13	Jan.	3½ yr	Ribs	Dudley	160	1.05	
14	Jan.	16½ yr	Tibia	Carlisle	250	0.25	
15	Jan.	50 yr	Tibia	Carlisle		0.06	
16	Jan.	65 yr	Tibia	Carlisle		0.13	
17	Jan.	Still	Sternum & femur	Carlisle		0.45	
18	Jan.	64 yr	Tibia	Carlisle		Not analysed	
19	Jan.	67 yr	Tibia	Carlisle		Not analysed	
20	Feb.	1½ yr	Femur	Carlisle		0.8	
21	Feb.	3 mo	Femur	Carlisle		1.3	
22	Jan.	33 yr	Ribs	Swindon		0.1	
23	Dec., 1955	18 yr	Ribs	Swindon	450	0.2	
24	Dec., 1955	40 yr	Ribs	Swindon		0.07	
25	Dec., 1955	34 yr	Ribs	Swindon	380		
26	Feb.	8 mo	Ribs	Birmingham		0.5	
27	Feb.	20 yr	Ribs	Birmingham	450	0.2	
28	Jan.	16 yr	Ribs	Birmingham		0.2	
29	Feb.	2 yr	Femur	Birmingham		0.55	
30	Feb.	11 yr	Femur	Birmingham	250	0.15	
31	Feb.	9½ yr	Femur	Birmingham	150	0.24	
32	May	1 mo	Femur	Herts		0.5	
33	Apr.	2 mo	Femur	Sussex		0.15	
34	June	1½ yr	Femur	Surrey		0.9	
35	May	2½ yr	Femur	London	530	0.8	
36	Apr.	8 yr	Femur	Middlesex	320	0.27	
37	May	12 yr	Femur	London	300	0.24	
38	May	14 yr	Femur	Surrey	420	0.17	
39	June	2 day	Femur	London		0.45	
40	July	7 day	Femur	Kent		0.15	
41	July	12 day	Femur	London	190	0.35	
42	July	3 day	Femur	London	240	0.8	
43	July	1 mo	Femur	London		0.4	
44	July	2 mo	Femur	Sussex		0.55	
45	June	5½ mo	Femur	London		1.1	1.0
46	June	6 mo	Femur	Bucks		0.75	
47	June	6 mo	Femur	London		1.2	1.1
48	July	6 mo	Femur	Blackpool		1.1	
49	July	2 yr	Femur	Middlesex		0.75	
50	July	2½ yr	Femur	Essex		0.70	
51	July	3½ yr	Femur	Sussex		0.64	
52	June	7½ yr	Femur	Essex		0.38	

Appendix 3—(Continued)

Ref.	Month	Age at Death	Bone	District	Sr, $\mu\text{g/g Ca}$	Sr ⁹⁰ , $\mu\text{mc/g of Ca}$	
						(a)	(b)
53	Dec.	2½ yr	Femur	Surrey		0.54	
54	Dec.	3 yr	Femur	Surrey		0.72	
55	Dec.	9 yr	Femur	Sussex		0.32	
56	Dec.	2 yr	Femur	Plymouth		1.55	1.35
57	Dec.	9 yr	Femur	Berks		0.27	
58	Dec.	7 yr	Femur	Norwich		0.35	
59	Dec.	4 mo	Femur	Cambridge		0.28	
1957							
60	Feb.	Still	Femur	Carlisle		0.65	
61	Mar.	1 yr	Femur	Keswick		2.3	2.1
62	Mar.	Still	Femur	Carlisle		0.5	
63	Mar.	Still	Femur	Carlisle		0.6	
64	Mar.	1 day	Femur	Carlisle		0.4	
65	Mar.	5 yr	Femur	Carlisle		0.5	
66	Apr.	8 yr	Femur	Birmingham		0.4	
67	Apr.	Still	Femur	London		0.7	
68	Apr.	Still	Femur	London			
69	Apr.	1 mo	Femur	London		0.9	
70	Apr.	7 yr	Femur	Birmingham		0.3	
71	May	5 mo	Femur	Birmingham	180		
72	May	13 yr	Femur	Liverpool	230	0.37	
73	May	2 yr	Femur	Liverpool	180	0.4	
74	May	6 mo	Femur	Liverpool	160	2.4	
75	May	6 mo	Femur	Liverpool	160	1.3	
76	June	Still	Femur	London			
77	June	Still	Femur	London	230	0.5	
78	June	Still	Femur	London			
79	June	Still	Femur	London	310	0.4	

N.B. The 1957 results above are included for completeness but are excluded from the summarized Tables 7 and 8 and from Fig. 7, which all relate to 1956.

Sr⁹⁰ activity: (a) estimated by total radiostrontium count. (b) estimated by Y⁹⁰ count.

Appendix 4—STABLE STRONTIUM IN BIOLOGICAL MATERIALS*
(Micrograms Sr per gram Ca)

A4.1 GRASS-SHEEP BONE COMPARISON

Station	Stable Sr		
	Grass	Sheep	Ratio
Cwmystwyth	5000	730	0.15
Vyrnwy	1500	470	0.31
Princetown	1700	470	0.28
Rookhope	2800	650	0.23
Norwich	2500	520	0.21
Boxworth	3400	930	0.27
Average	2800	630	0.24

Compare Bowen & Dymond (1955).
Meadow plants (9 samples) ranged from
2200 to 6130.

A4.2 FEED-COWBONE-MILK COMPARISON AT READING

Silage	2400	Straw	2400
Kale	1300	Cowbone	520
Concentrate	3300	Milk	330

A4.3 COMPARISON OF LOWLAND AND HILL SHEEP (INCLUDING THOSE LISTED ABOVE AND OTHERS)

	No.	Mean	S.E.
Lowland	8	710	78
Hill	10	530	64

A4.4 MILK†

Source	AERE	MRC
Frome	230	220
Carmarthen	200	210
Ballymoney	270	
Carlisle	410	420
Coleraine	280	350
Driffield	240	250
Reading	330	

A4.5 OTHER FOODS (BOUGHT AT HARWELL)

Cheese	550	Cereal (Farex)	2200
Potatoes	2500	Flour	2100
Carrots	2900	Rice	1550
Cabbage	2900		

(Compare Harrison et al. (1955): Mixed
diet, including milk, 1700)

A4.6 HUMAN BONES

Age	AERE		MRC*	
	No.	Av.	No.	Av.
0-6 mo.	7	210	7	200
1-18 y.	10	280	9	230
>18 y.	6	390	18	265

*Results of Sowden and Stitch (1956)
by activation analysis.

*AERE results by Spectrographic Section, Woolwich Outstation, Chemistry Division, AERE.

†Results by AERE (Spectrographic) and MRC (Harrison, activation).

THIS PAGE
WAS
INTENTIONALLY
LEFT BLANK
IN
ORIGINAL

THE WORLD-WIDE DEPOSITION OF LONG-LIVED FISSION PRODUCTS FROM NUCLEAR TEST EXPLOSIONS*

By N. G. Stewart, R. G. D. Osmond, R. N. Crooks, and Miss E. M. Fisher

U.K.A.E.A. Research Group, Atomic Energy Research Establishment, Harwell

ABSTRACT

Measurements of the gross fission product activity deposited since 1951 at two stations in the U. K. have been described in an earlier report.¹ A network of six stations in the U. K. and thirteen in other parts of the world has now been set up at which rain water is collected over monthly or three-monthly periods and analyzed for Sr⁸⁹, Sr⁹⁰, Cs¹³⁷, and Ce¹⁴⁴. The stations have been commissioned at intervals since the first was set up in May 1954 and an account is given of the results obtained so far, particularly on Sr⁹⁰ for which the records are the most complete.

It is shown that most of the Sr⁹⁰ deposited is derived from those nuclear explosions whose clouds enter the stratosphere and return to earth slowly over a number of years. In the successive yearly periods between May 1954 and May 1957 the Sr⁹⁰ deposition at a representative station in the U. K. amounted to 2.06, 2.24 and 2.55 mc/km², respectively, and the cumulative total in May 1957 was 7.5 mc/km². Cesium-137 levels are about 50% higher than those of Sr⁹⁰. The experimental data indicate that, within a given region, fallout is proportional to rainfall. Based on some simple assumptions about the frequency of nuclear weapon tests in the future, estimates are made of the possible future levels of Sr⁹⁰ in soil in the U. K.

It has been found that the mean Sr⁹⁰ concentration in rain water in the U. K. shows a marked seasonal variation with peaks in the late spring and troughs in the late autumn of 1955 and 1956, and the concentration in the lower stratosphere appears to vary in a similar manner. The maximum to minimum ratio is about 6:1. A similar but less marked variation of the opposite phase has been observed in New Zealand rain water. It has also been observed that the deposition rate of Sr⁹⁰ has a minimum value near the equator, and there appears to be a pronounced maximum in the middle latitudes of the northern hemisphere. These results are shown to be consistent with a model for the general circulation of the atmosphere proposed by Dobson⁶ and Brewer⁷ as a result of their observations of ozone and water vapour in the atmosphere.

Some proposals for future work on the meteorological problems of long-range fallout are given in the report.

1 INTRODUCTION

In a recent paper,¹ an account was given of the method used in the U. K. for measuring the rate of deposition of Sr⁹⁰ from nuclear test explosions. The measurements, which were con-

*Received from the Atomic Energy Research Establishment as report A.E.R.E. HP/R 2354, dated October 1957.

fined to one station only, showed that the deposition rate increased after the thermonuclear tests in the Pacific in 1954 and maintained a mean value of 2.3 mc/km²/year throughout the period ending April 1956. This result was shown to be consistent with the fact, established independently, that the debris from large-scale nuclear explosions is stored in the stratosphere and is returned to earth slowly over a number of years.

With only one sampling station it was not possible to deal with the important questions of the uniformity of this deposition over the U. K. and over the earth's surface. A network of six stations in the U. K. and thirteen in other parts of the world has now been set up, at which rain water is collected over three-month periods and analyzed for Sr⁸⁹, Sr⁹⁰, Ce¹⁴⁴, and Cs¹³⁷. Some of these stations have been in operation since the middle of 1955 and an account is given in this report of the results obtained so far. The non-uniformity observed in the world pattern of deposition shows that such global surveys are essential for a true assessment of the fallout problem, while the results as a whole throw some interesting light on the mechanism whereby fission products are transferred from the stratosphere to the troposphere and deposited on the ground by rain water.

Table 1—LIST OF RAIN WATER COLLECTION STATIONS

Station	Latitude	Longitude	Mean annual rainfall, cms	Sampling commenced
Kinloss	57° 39'N	03° 34'W	70	January 1956
Liverpool	53° 21'N	02° 58'W	85	January 1956
Snowdon*	53° 04'N	04° 01'W	300	October 1956
Abingdon	51° 41'N	01° 18'W	65	July 1955
Milford Haven†	51° 41'N	05° 09'W	75	May 1954
Felixstowe	51° 58'N	01° 20'E	55	January 1957
Tromso	69° 42'N	19° 01'E	68	June 1957
Bodo	67° 17'N	14° 22'E	87	July 1957
Esquimalt	49° 30'N	123° 00'W	79	October 1957
Ottawa	45° 20'N	75° 41'W	100	July 1956
Gibraltar	36° 10'N	65° 21'W	90	July 1955
Caenwood	18° 13'N	76° 35'W	280	July 1957
Palisadoes	17° 56'N	76° 47'W	80	July 1957
Port Harcourt	04° 45'N	07° 20'E	250	January 1956
Singapore	01° 19'N	103° 49'E	240	July 1955
Suva	18° 05'S	178° 28'E	290	July 1955
Melbourne	37° 45'S	144° 50'E	65	January 1956
Ohakea	40° 12'S	175° 23'E	100	July 1955
Port Stanley	51° 42'S	57° 52'W	65	February 1956

* Two stations one 335 m higher than the other.

† Monthly and three-month samples.

2 NETWORK OF RAIN WATER COLLECTION STATIONS

A list of the stations in current operation, arranged in order of latitude is given in Table 1 together with the dates when sampling commenced. The period of sampling at all stations is three months (January to March, April to June, etc.) but the monthly sampling at Milford Haven, which was started in May 1954 has been continued to provide some finer detail. The stations in the mountainous region near Snowdon were chosen because the rainfall there is about four times the average for the U. K.; one of the two stations is at an altitude 335 metres above the other. The recently commissioned stations in the West Indies, Caenwood and Palisadoes, were selected because they have quite different rainfall patterns although they are close together geographically.

Sampling at latitudes north and south of 60°N and 55°S, respectively, is difficult because of the lack of suitable stations and because of the problems associated with snow sampling. Through the kindness of T. Hvinden of the Norwegian Defence Research Establishment, snow cores and samples of summer rain have been obtained from latitudes up to 70°N. Through the

courtesy of Dr. Lister of the British Transantarctic Expedition, snow cores have been obtained from 78°S 37°W where summer melting is negligible, and arrangements have been made to obtain fresh snow samples from 82°N to 70°W.

3 SAMPLING PROCEDURE

At each station rain water is collected in a 4.5 liter polythene bottle through a polythene funnel with a 5 cm rim and a diameter of 10 cm or 20 cm according to the mean rainfall. When the collecting bottle is nearly full, or at the end of a sampling period, the water is transferred to a polythene transit bottle and returned to the laboratory, where carriers are added and radiochemical analysis carried out. An exception is made in the case of the monthly collector at Milford Haven where carriers are added before the rain falls, and the good agreement between the results obtained for Sr⁹⁰ on the monthly and three-monthly collector on the same site has served as a check on the reliability of the latter system for sampling this isotope.

The radiochemical procedures have been described in another report.²

On certain sites particularly, it has been found that the quantity of rain water collected does not correspond with that collected on the immediately adjacent standard rain gauge. The tendency has been for the polythene funnel to collect rather more than the rain gauge and discrepancies as high as 25 per cent have been found. It is probable that this phenomenon will occur with most types of collector. The procedure adopted here is to compute the specific activity of the rain water using the volume of water in the collector and then to compute the fallout per unit area using the rainfall figures from the standard rain gauge.

4 SOME GENERAL FEATURES OF THE DEPOSITION PROCESS

It is necessary at this stage to discuss some general features of the deposition process which are relevant both to the sampling method used and to the treatment and interpretation of the data obtained.

The first concerns the relative importance of the two ways in which very fine dust is removed from the atmosphere: (1) by washout in rain water; (2) by dry turbulent deposition onto surfaces.

A previous report¹ quoted evidence to show that the former was by far the more important process, particularly in the case of dust fed down from the stratosphere. Nevertheless, if a collecting funnel is exposed to the atmosphere for a lengthy period, significant amounts of radioactive dust will be deposited on the inner surface by turbulent deposition, and if the amount of rain during the period of exposure is small, the specific activity of the water in the bottle will be much higher than that of the falling rain. Some experiments have been carried out which allow an empirical correction to be made for this effect when the concentration of activity in ground level air is known throughout the period of exposure.

In the first place, the deposition of fission product activity onto horizontal sheets of gummed paper was measured daily over a period of weeks together with the concentration of activity in the air at ground level. The deposition velocity V_g defined by

$$V_g(\text{cms/sec}) = \frac{\text{rate of deposition of activity per cm}^2 \text{ per sec}}{\text{concentration of activity per cm}^3 \text{ of air}}$$

was found to have a mean value of 0.07 cm/sec which compared well with the mean value obtained by Megaw for the deposition of small particles onto filter papers.³ It is reasonable to expect that the nature of the surface is unimportant in the case of very fine particles, provided there are no large electrostatic charges. In a separate series of experiments, one of the standard polythene collecting funnels was lined on the inside with gummed paper and the deposition of fission products compared with that on flat sheets of gummed paper erected alongside. Over a period of twenty days it was found that the amount deposited on the inside of the funnel was equivalent, within 3%, to that on a flat sheet of paper of area equal to that of the cross-section of the funnel. Thus the dry rate of deposition of airborne activity onto the inside of the polythene funnel may be also taken to be 0.07 cm/sec.

The second feature of the deposition process concerns the variation of the rate of deposition during the course of a shower. Experiments carried out at Harwell show that this is a real effect. For some years, the fission product activity in the troposphere has been sampled regularly by fitting filters to aircraft carrying out standard meteorological flights from Aldergrove, Northern Ireland.¹ At the same time, measurements have been made of the gross activity in ground level air and of the activity of rain water at Harwell. It has been shown from the air measurements that, except when fresh dust clouds are crossing the U. K. for the first time, the mean gradient of activity in the lower troposphere following nuclear explosions in the "normal" size range is comparatively constant for different series of tests. It is possible, therefore, to scale the rain water activities following such tests to correspond to a fixed activity level in the troposphere. Normalized figures for the specific activity of rain water samples calculated in this way have been separated into groups according to the amount of rain which fell during the collection of the samples and an average figure computed for each group. The results are plotted in Fig. 1 which clearly shows that the specific activity of rain water de-

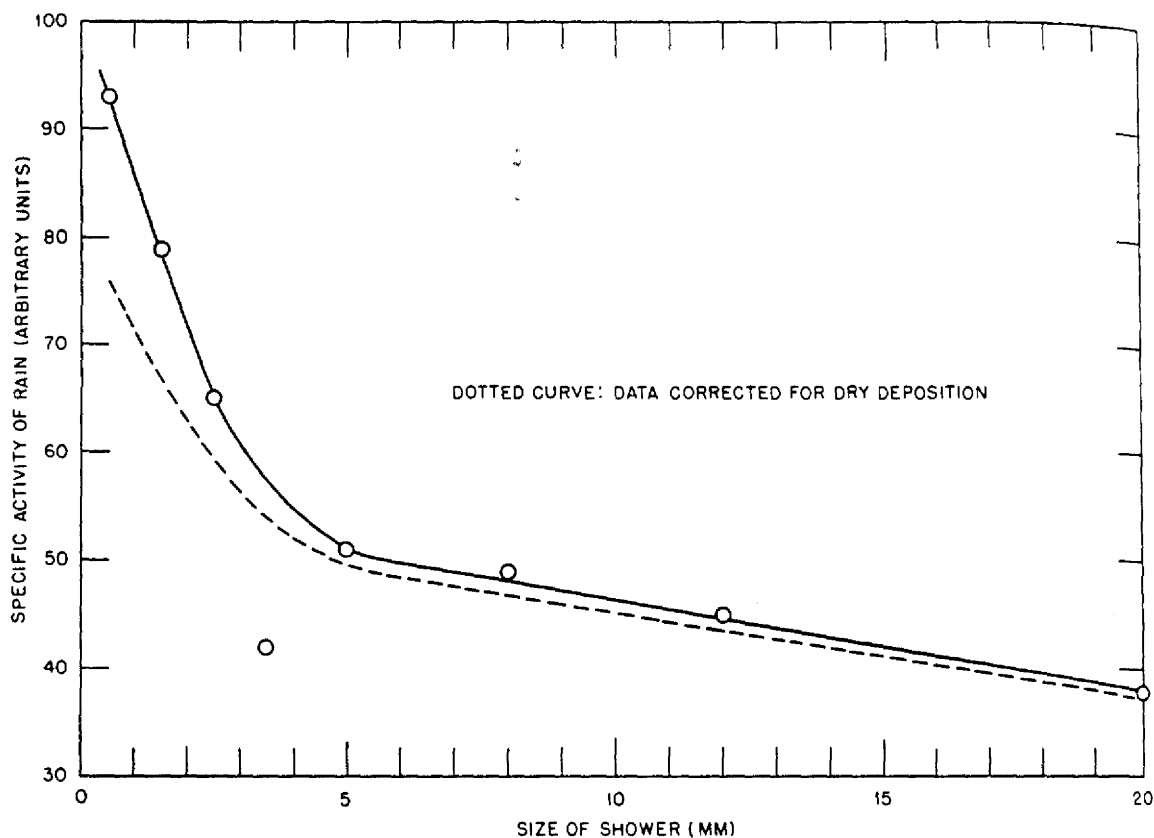

Fig. 1—Variation of specific activity of rain water with size of shower.

creases with the amount of rain that falls. The effect of dry deposition on this graph, greatest at low rainfalls, has been computed using the slightly exaggerated value of 0.1 cm/sec for the deposition velocity, and the corrected curve is also shown in Fig. 1. It is clear that the observed effect is not due primarily to dry deposition and it follows that the specific activity of rain water is a decreasing function of the amount of rain which falls. Further experiments are being carried out on this aspect of deposition.

5 RESULTS OF DEPOSITION MEASUREMENTS IN THE U. K.

The results obtained from the radiochemical analysis of the monthly samples collected at Milford Haven are given in Table 2 in which the activities are expressed on the last day of each sampling period. The Sr^{90} data are given both in terms of the specific activity of the rain water

Table 2—DEPOSITION DATA FROM MILFORD HAVEN, U. K.

Sample number	Period ending*	Rainfall, cms	Sr ⁹⁰ in rain, $\mu\text{c}/\text{litre}$	Sr ⁹⁰ , mc/km^2	$\frac{\text{Cs}^{137}}{\text{Sr}^{90}}$	$\frac{\text{Sr}^{89}}{\text{Sr}^{90}}$	$\frac{\text{Ce}^{144}}{\text{Sr}^{90}}$
<u>1954</u>							
1	May 13	6.50	0.45	0.017			
2	June 5	2.70	1.8	0.13			
3	June 20	2.66	1.5	0.14			
4	July 24	1.26	1.2	0.057			
5	Aug. 9	10.04	0.60	0.028			
6	Aug. 24	5.51	1.4	0.075			
7	Sept. 27	8.78	1.2	0.11			
8	Oct. 18	9.26	1.8	0.16			
9	Nov. 9	12.19	1.5	0.19			
10	Nov. 29	13.45	1.3	0.18			
11	Dec. 20	9.43	1.2	0.11			
<u>1955</u>							
12	Jan. 10	1.21	3.1	0.038			
13	Jan. 31	6.83	1.9	0.13		21.9	
14	Feb. 21	4.94	6.1	0.30			
15	Mar. 14	0.52	2.4	0.013			
16	Apr. 4	7.28	2.2	0.16		1.46	
17	Apr. 25	2.46	5.0	0.12		9.55	
18	May 16	8.03	4.4	0.36		0.89	
19	June 6	4.11	7.6	0.31		5.66	
20	July 4	8.54	3.4	0.29		3.49	
21	Sept. 5	3.27	5.4	0.18		1.36	
22	Sept. 26	2.63	3.8	0.10		0.51	
23	Oct. 17	2.20	1.7	0.039		0.91	
24	Nov. 7	10.48	0.91	0.093		0.47	
25	Nov. 28	2.95	1.2	0.036		1.45	
<u>1956</u>							
26	Jan. 2	17.06	1.4	0.25		19.22	
27	Jan. 23	10.44	2.4	0.25		6.56	
28	Feb. 13	4.11	4.0	0.16		0.27	
29	Mar. 5	1.53	7.9	0.12		10.53	
30	Mar. 26	1.61	4.5	0.073		7.55	
31	Apr. 16	1.03	9.4	0.097		5.30	15.49
32	May 7	0.99	7.6	0.075		4.10	11.60
33	May 28	2.62	7.0	0.18		3.91	8.56
34	June 18	5.62	4.7	0.27	1.75	2.41	5.31
35	July 9	1.86	9.1	0.17	1.89	2.48	7.26
36	Aug. 1	7.72	2.1	0.16	2.27	8.38	11.45
37	Sept. 3	8.79	2.0	0.18	2.12	16.43	8.99
38	Sept. 28	9.19	2.0	0.18	2.00	44.56	11.87
39	Nov. 1	4.34	4.0	0.17	1.66	29.60	11.83
40	Dec. 1	4.37	2.2	0.097	1.81	22.49	13.82
<u>1957</u>							
41	Jan. 1	14.55	2.0	0.29	1.82	15.41	20.73
42	Feb. 1	5.79	4.0	0.23	1.83	16.45	14.37
43	Mar. 1	7.49	2.9	0.22	2.32	15.19	21.80
44	Apr. 1	9.53	4.7	0.45	2.09	10.86	14.80
45	May 1	0.43	14.5	0.063	2.25	8.93	22.77

* Sampling commenced May 1, 1954, and was continuous over the measuring periods.

(column 4) and in terms of the amount deposited per unit area (column 5). The amounts of Sr^{89} , Cs^{137} , and Ce^{144} are expressed relative to the Sr^{90} activity.

The cumulative curves of deposition of Sr^{89} and Sr^{90} have been computed from the data in Table 2 and are plotted in Fig. 2. It will be seen that the deposition rate of Sr^{90} has been maintained¹ and that the total deposition in 1956 was about 8% greater than that in 1955 although the annual rainfall was 4% less.

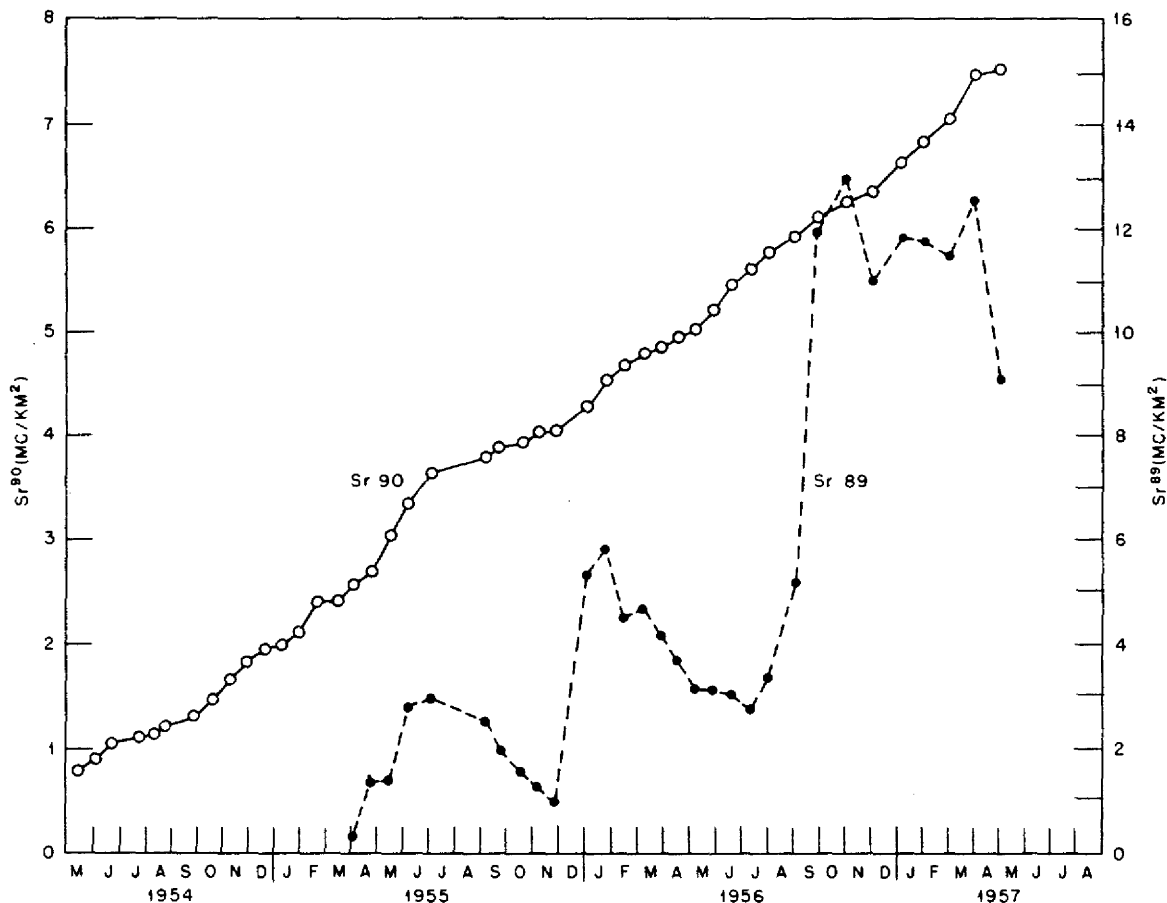

Fig. 2 — Cumulative deposition of Sr^{89} and Sr^{90} at Milford Haven.

The specific Sr^{90} content of the Milford Haven rain water has been plotted against time in Fig. 3 in which the figures have been grouped in approximately two monthly intervals to smooth out shorter period variations. The graph reveals a marked seasonal variation in the specific activity of the rain water, with peaks in the late spring and troughs in the late autumn of both 1955 and 1956 and in indication of an approaching peak in the late spring of 1957. There are three possible explanations for such a result:

(1) The curve is primarily a function of the amount and of the type of rain falling during the sampling periods, the controlling factors being dry deposition and the higher washout efficiency of small showers (para. 3).

(2) The form of the curve is determined by the dates of weapon testing programmes, each peak being associated with an immediately preceding series of explosions. This interpretation implies that the fallout is primarily tropospheric* and has been airborne for a relatively short time.¹

* Tropospheric fallout refers to radioactive dust particles which have never risen above the tropopause. Stratospheric fallout refers to particles which have spent part of their life in the stratosphere; these return ultimately to the troposphere to be deposited by the same processes as the tropospheric fallout.

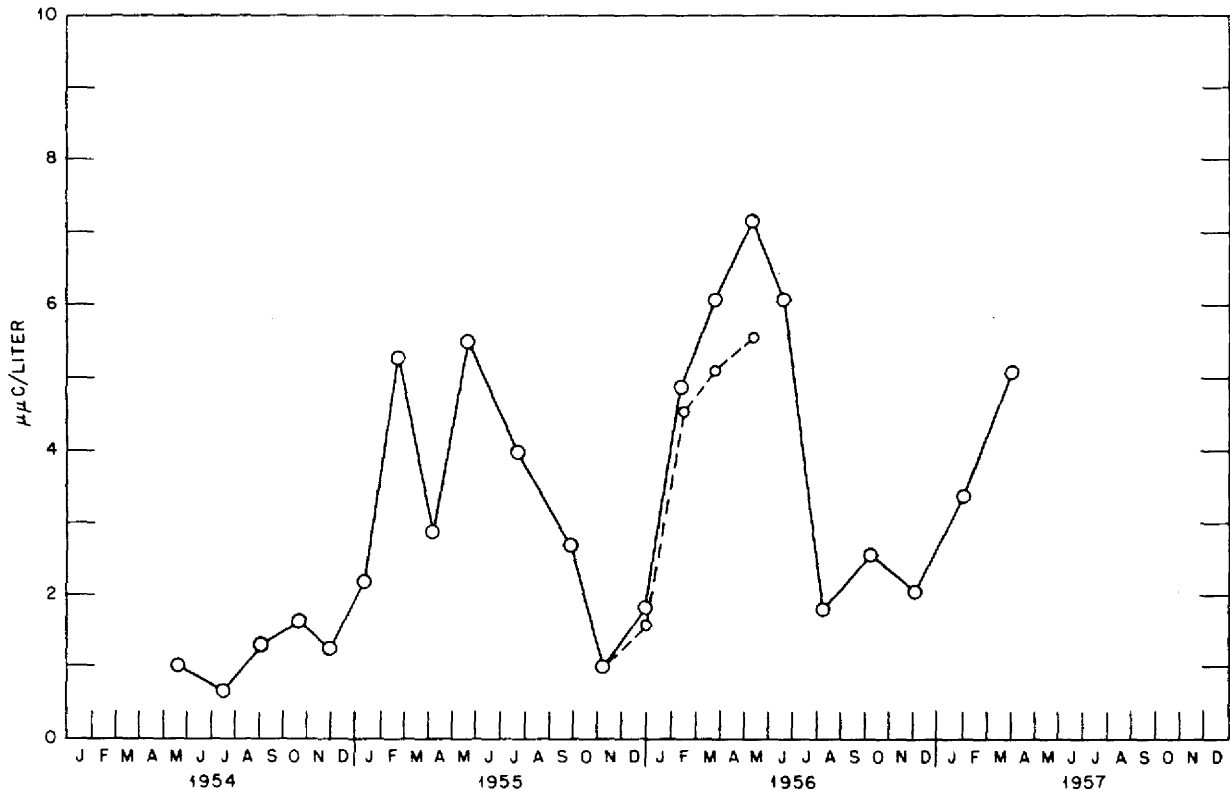

Fig. 3—Sr⁹⁰ content of rain water at Milford Haven.

(3) The Sr⁹⁰ deposited is primarily derived from dust which has been stored in the stratosphere and which, for meteorological reasons, is being fed down slowly into the lower atmosphere in a periodic manner.

It is comparatively simple to exclude possibilities (1) and (2) but the detailed arguments are lengthy and they are given in Appendices 1 and 2.

It is shown in Appendix 1 that the dry deposition and rainfall factors have little effect on the shape of Fig. 3 and that the latter reproduces the shape of the air concentration curve to within 15%. It would nevertheless be useful to demonstrate by direct measurement that the concentration of long-lived fission products in the troposphere has varied in the same cyclic manner as Fig. 3. A programme along these lines has been started at Harwell in which the Cs¹³⁷ on tropospheric filters collected over the past few years will be measured on a gamma-ray spectrometer.

The main arguments against hypothesis (2)—that the peaks are due to tropospheric fall-out—are given in Appendix 2 and are based on the known rapid deposition of tropospheric dust, the amount of 54-day Sr⁸⁹ present in the samples, the decay properties of the gross deposited radioactivity and knowledge of the very small amounts of Sr⁹⁰ deposited in the U. K. from the testing of nominal-size nuclear weapons prior to January 1955.

The continuing deposition of Sr⁹⁰ from the 1954 thermonuclear tests was anticipated in our previous report¹ in which the deposition rate of the dust was calculated to be 12% per year, which is in good agreement with Libby's estimate of a mean stratospheric storage time of ten years.⁴ The possibility of a periodic variation in the rate of deposition was not anticipated, but in a later section this result will be shown to support an atmospheric circulation model deduced from the measured distribution of ozone in the atmosphere.

The exact contributions of explosions subsequent to 1954 to the deposition of Sr⁹⁰ are not easy to determine, particularly in the absence of information about the amount of material in the stratosphere. Using the Sr⁸⁹ data given in Table 2, it is possible to compute the associated amount of Sr⁹⁰ when the date of origin of the Sr⁸⁹ is known, using published fission product yields (Sr⁸⁹/Sr⁹⁰ yield ratio = 0.81). By this method, it is deduced in Appendix 2 that tests staged in 1955 were responsible for less than 5% of the Sr⁹⁰ deposited at Milford Haven in that year. The

situation in the first half of 1956 became complex as a result of the Russian explosion in November 1955. This test was announced as being "in the megaton class" and the associated fresh fission products were observed some time later in the lower stratosphere above the U. K. Two other tests of unspecified magnitude were announced in the spring of 1956. An upper limit can be derived for the Sr^{90} contribution of these three tests to the amount deposited at Milford Haven between January and May 1956 by attributing all the deposited Sr^{90} to the test of November 1955. With this assumption, the associated Sr^{90} has been computed and subtracted from the observed amount in each sampling period, giving the dotted curve in Fig. 3 which must represent, in the main, a lower limit for the amount of Sr^{90} still attributable to the 1954 tests. After May 1956 it is not possible to fix the date of origin of the observed Sr^{90} but, as is shown in Appendix 2, the data still point to the fact that the Sr^{90} deposited is primarily of stratospheric origin.

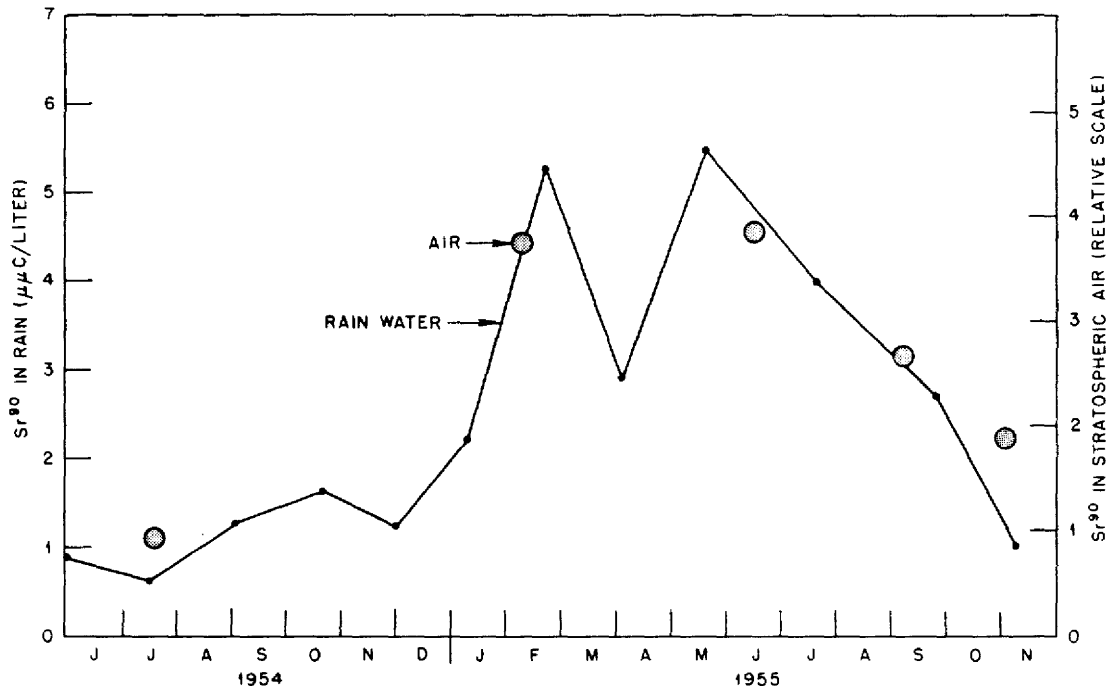

Fig. 4—Correlation between Sr^{90} concentrations in rain water and in the lower stratosphere.

An interesting result, supporting the stratospheric origin of the Sr^{90} deposited during the period July 1954 to October 1955, shows a marked correlation between the concentration of Sr^{90} in rain water and that in the lower stratosphere. The Sr^{90} concentration in the stratosphere was computed from the gross radioactivity collected, since during this period the lower stratosphere contained fission products from the 1954 Eniwetok tests only. The correlation is demonstrated in Fig. 4 where the stratospheric content is plotted on a scale in which the mean concentrations at both 13,400 metres and 14,600 metres have been expressed relative to the values found at these heights in July 1954. Stratospheric samples collected at later dates will be examined by the gamma spectrometer to determine if the correlation is maintained.

Figures for the amount of Sr^{90} deposited at the other U. K. stations are given in the upper part of Table 3. The differences between the amounts deposited at the stations over common periods reflect different rainfall rates rather than differences in the specific contents of the rain. In the following table, the over-all specific activities of the rain water at the various sites have been expressed as percentages of that at Milford Haven over the common period of sampling. Rainfall rates have been similarly expressed:

Station	Kinloss	Liverpool	Snowdon	Abingdon	Milford Haven	Felixstowe
Relative specific activity of rainfall	90	88	80	106	100	102
Relative rainfall rates	89	84	409	68	100	42

The specific activity of the rain is apparently insensitive to the amount of rain which falls, and there are therefore very good grounds for believing that the cumulative deposition of Sr^{90} at any point in the U. K. will be proportional to rainfall. The results of Bryant et al.⁵ obtained from the radiochemical analysis of soils confirm this. It appears that over a reasonable averaging period, each site receives its rain in showers of a sufficiently random nature that the effects which might otherwise be expected from the results of Fig. 1 do not arise.

Table 3—QUARTERLY DEPOSITION OF Sr^{90} IN VARIOUS PARTS OF THE WORLD (mc/km² OF Sr^{90})

Station	1955		1956				1957	
	3	4	1	2	3	4	1	2
Kinloss			0.72	0.43	0.56	0.60	0.76	
Liverpool			0.60	0.85		0.27	0.59	
Snowdon					1.40	2.44	3.22	
Abingdon	0.22	0.76	0.62	0.62	0.58	0.39	0.33	
Milford Haven	0.25	0.76	0.62	0.71	0.75	0.57	0.85	
Felixstowe							0.36	
Ottawa					0.60	0.52		
Gibraltar	No rain	0.97	2.44	1.69		1.01	0.66	
Port Harcourt			0.19	0.39	0.49	0.33		
Singapore	<0.014	0.055	0.055	0.055	0.19	0.093	0.11	
Suva	<0.11		0.091	0.13	0.31	0.52		
Melbourne			0.20	0.20	0.23	0.32		
Ohakea	0.14	0.35	0.11	0.25	0.32	0.29		
Port Stanley				0.12	0.20	0.19		

The total Sr^{90} fallout at Milford Haven between June 1, 1955, and April 1, 1957, determined by quarterly samples is within 3% of the value obtained on the monthly sampling system. This is not only a satisfactory check on the radiochemical analysis but on the sampling procedures which differ in that carrier is not added to the quarterly samples until they are returned to the laboratory for analysis.

6 RESULTS OF DEPOSITION MEASUREMENTS ON WORLD NETWORKS

The amounts of Sr^{90} deposited in three-monthly periods in the world network are given in the lower part of Table 3. The most striking features are the consistently very low values for the fallout at Singapore, which is nearly on the equator, and the relatively low values in the southern hemisphere. Since the stations were commissioned at different times, it is not possible to plot the total fallout figures in a straightforward manner. In Fig. 5a the total deposition of Sr^{90} during 1956 is plotted against latitude at each station where observations were continuous throughout the year. Also plotted are figures derived from stations where observations were made for nine months only, but here each station has been allocated a value whose ratio to the mean value at Milford Haven and Abingdon for the twelve month period is the same as the ratio determined over the shorter common period.

The specific activity of the rain water has been averaged over the total period of sampling at each station and the type of normalizing procedure described in the last paragraph used to derive the values plotted in Fig. 5b. In this instance the specific activities at stations in the

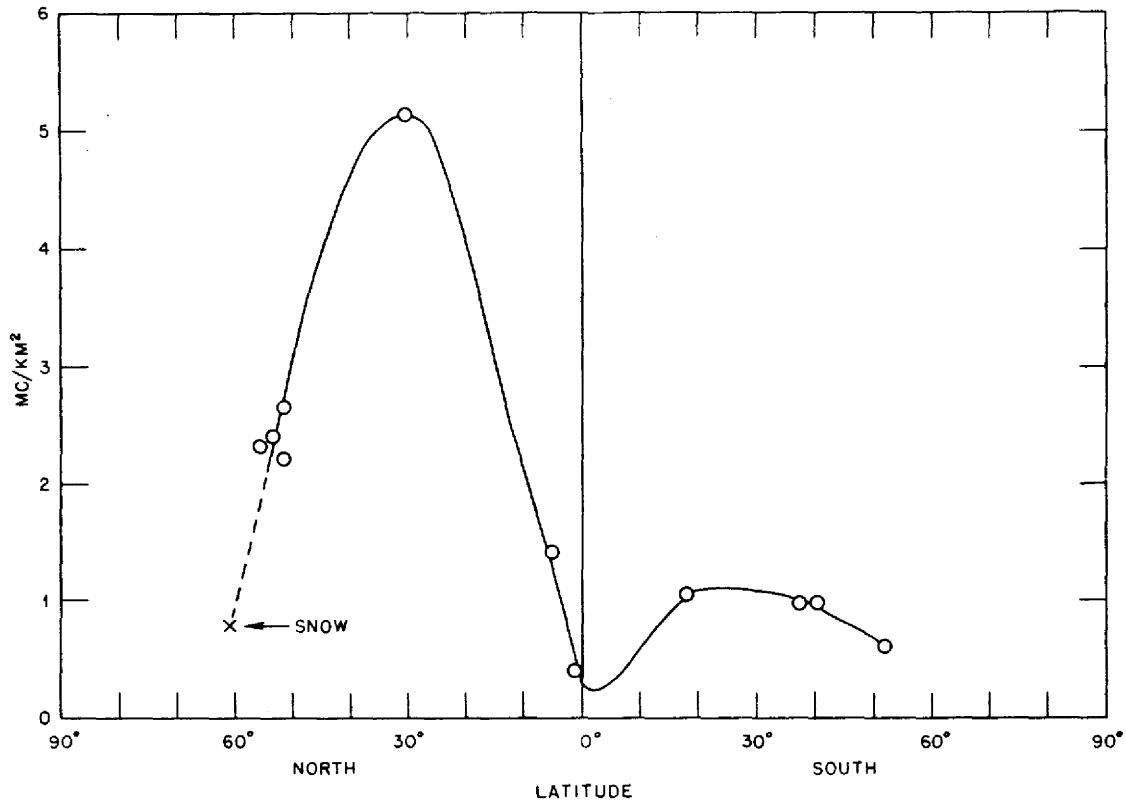

Fig. 5a—Total deposition of Sr⁹⁰ in 1956 at various latitudes.

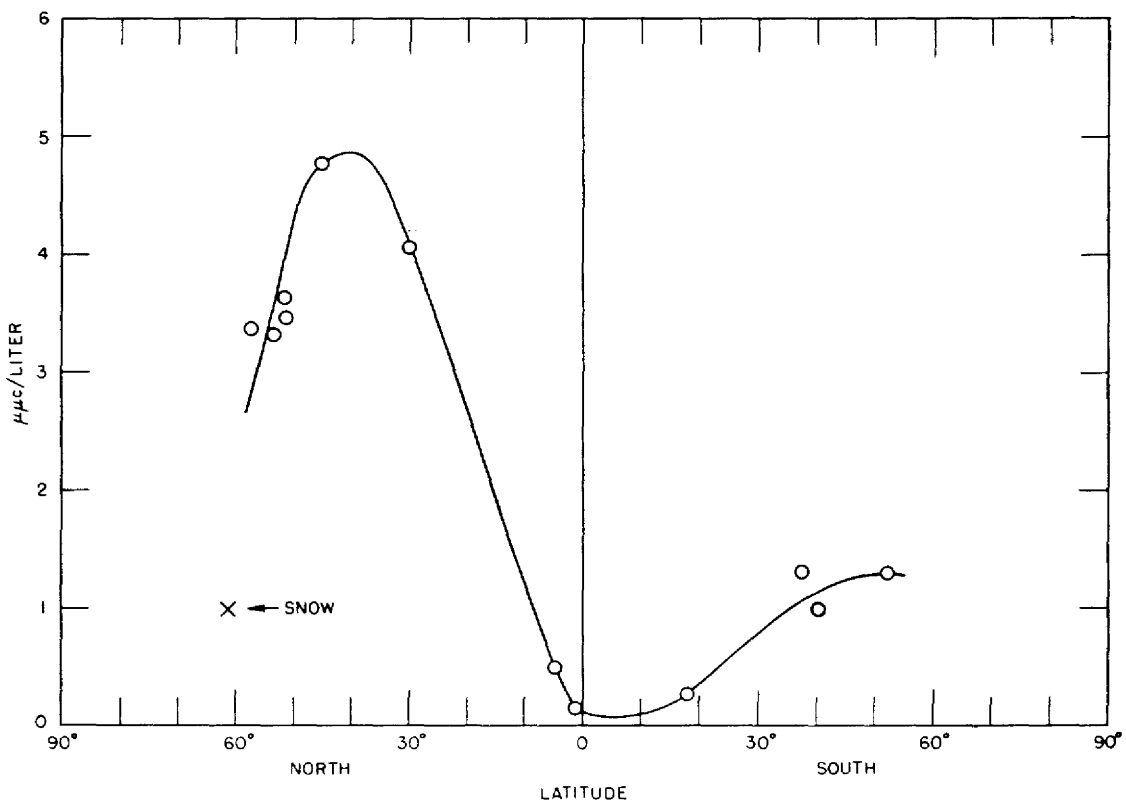

Fig. 5b—Mean Sr⁹⁰ content of rain water at various latitudes (1955-1957).

northern hemisphere have been adjusted using the mean of the values obtained at Milford Haven and Abingdon as reference but for the southern hemisphere stations, Ohakea has been used. Figures 5a and 5b have the same general characteristics, with a pronounced minimum near the equator, a strong suggestion of a maximum in the middle latitudes in the northern hemisphere and a possible smaller maximum in a similar region of the southern hemisphere. The low point plotted at 63°N on each diagram was obtained from the analysis of a snow core from Norway; this point might be artificially low as there has undoubtedly been some melting of the snow in the summer and there is a possibility that the percolating water might remove Sr⁹⁰ preferentially.

An interesting results is demonstrated in Fig. 6 in which the specific activities of the quarterly samples at Milford Haven and at Ohakea have been plotted. The Milford Haven curve

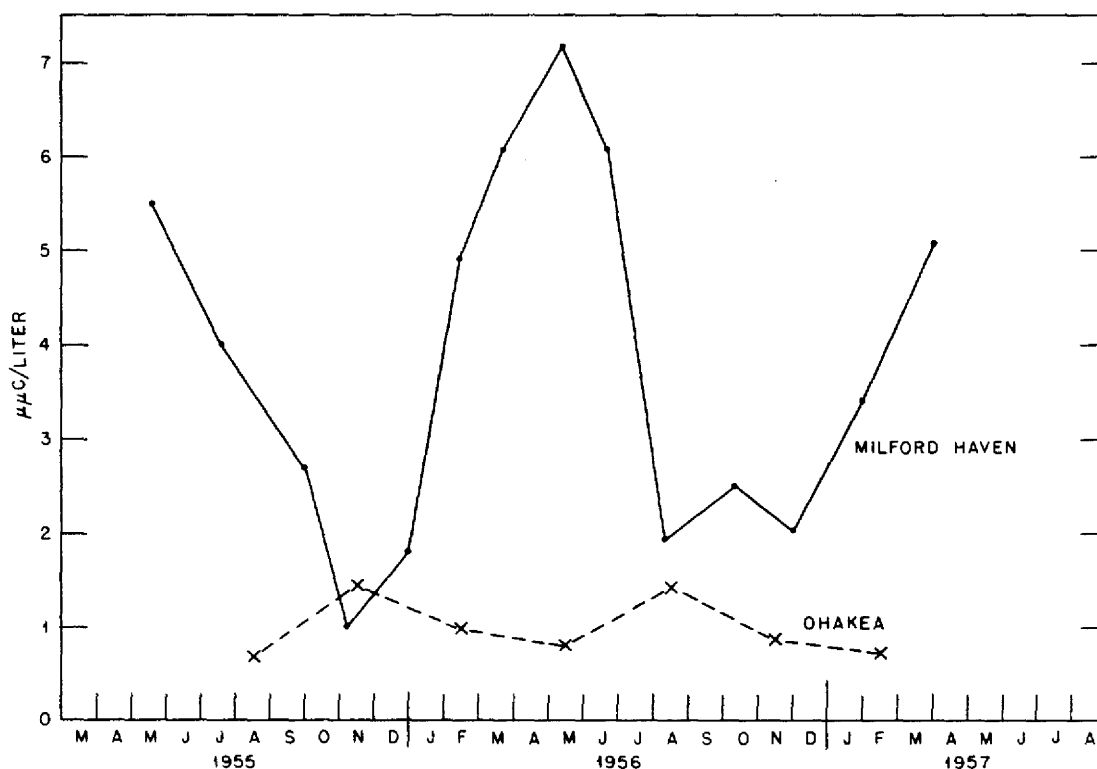

Fig. 6—Seasonal variation of Sr⁹⁰ content of rain water at Milford Haven and Ohakea.

is a portion of the curve in Fig. 3, showing the pronounced seasonal effect. The New Zealand curve also shows a seasonal effect but of the opposite phase to that in the northern hemisphere. This result will be discussed further when all the data are examined in terms of a model of general circulation of the atmosphere.

7 THE RATIO OF Cs¹³⁷ TO Sr⁹⁰ IN RAIN WATER

From radiochemical analysis and gross activity measurements of several samples of stratospheric dust collected at various times after the 1954 thermonuclear tests, a value of 4% has been obtained for the effective fission yield of Sr⁹⁰ in such tests. Cs¹³⁷ is situated in one of the peaks of the fission product yield curve and its yield should therefore be about 6% and comparatively insensitive to the type of fission. Since the half lives of Cs¹³⁷ and Sr⁹⁰ are nearly equal, one might therefore expect to find Cs¹³⁷/Sr⁹⁰ ratios of the order of 1.5 in airborne dust and in rain water. The actual values obtained from the quarterly rain water samples are given in Table 4 together with values of the mean determined from the ratio of the

Table 4—RATIO OF Cs¹³⁷ TO Sr⁹⁰ DEPOSITED IN VARIOUS PARTS OF THE WORLD

Station	1955		1956				1957		Mean value*
	3	4	1	2	3	4	1	2	
Kinloss			1.29	1.76	1.56	1.03	0.86		1.25
Liverpool			1.92	2.93		2.47	1.79		2.32
Snowdon					1.44	0.89	1.45		1.25
Abingdon	1.22	0.69	1.45	2.36		1.63	2.64		1.58
Milford Haven		1.68	1.71	1.63	1.90	1.40	1.68		1.68
Felixstowe							1.24		1.24
Ottawa					1.79	1.52			1.66
Gibraltar		0.78	0.40	0.45		0.64	0.47		0.51
Port Harcourt				1.26	1.52	2.48	1.20		1.66
Singapore	1.00	1.25	2.45	1.76		2.00	1.20		~1.66
Suva	2.16		2.51	4.87	3.50	0.32	2.10		~2.01
Melbourne			0.29	0.60	0.46	0.60	0.35		0.49
Ohakea	2.17		1.89	3.50	1.47	1.56	1.27		1.99
Port Stanley				2.22	1.40	1.47			1.71

$$* \text{ Mean value} = \frac{\text{Total Cs}^{137} \text{ deposited}}{\text{Total Sr}^{90} \text{ deposited}}$$

total Cs¹³⁷ to total Sr⁹⁰ deposited at each site. It is clear that there is a considerable scatter in the values of the ratio. The statistical errors involved in counting the Sr⁹⁰ and Cs¹³⁷ are only of the order of 1 or 2%; all the errors involved in the chemical processing and source preparation have been estimated to be about ±5% but even allowing an error of ±10%, the ratios of the two isotopes would be expected to be distributed with an error of ±15%. The mean of all the values obtained is 1.50 as expected but it is obvious that consistently low values, well outside the statistical margin of error, are obtained at Gibraltar and Melbourne, with fairly high values at Liverpool. No satisfactory meteorological explanation is as yet forthcoming for this phenomenon. The possibility cannot be ignored that the phenomenon is not a true one but is a feature of the sampling system. This is thought to be unlikely, as the procedure is exactly the same at all stations, but the polythene collecting bottles at several stations, including Gibraltar and Liverpool, are being returned to the laboratory to be examined radiochemically for evidence of adsorption of Cs¹³⁷ in particular. The excellent agreement between the Sr⁹⁰ collected at Milford Haven in the two independent systems with and without carrier has already been noted. It is noticeable, however, that the mean Cs¹³⁷/Sr⁹⁰ ratio obtained on the carrier-free quarterly collecting system at Milford Haven is about 16% less than that derived from the monthly system where carrier is always present.

In addition to the check on the collecting system, an experiment is currently being carried out at Gibraltar in which the Cs¹³⁷/Sr⁹⁰ ratios in rain water samples are being compared with the ratios obtained from dust samples collected from the air in the troposphere above Gibraltar.

8 Sr⁹⁰ AND THE GENERAL CIRCULATION OF THE ATMOSPHERE

The programme of measurements has revealed certain general facts about the Sr⁹⁰ in the atmosphere, in rain water and on the surface of the earth:

(1) Since 1954, nearly all the Sr⁹⁰ deposited at places remote from test sites has been derived from large-scale nuclear explosions and has been fed down gradually from the stratosphere.

(2) The concentration of Sr⁹⁰ in rain water, and hence in tropospheric air, shows a genuine seasonal variation, having opposite phases in the two hemispheres. There is a strong indication, in the northern hemisphere at least, that this variation is in step with a similar variation in the lower stratosphere.

(3) The greatest deposition takes place in the middle latitudes.

(4) Deposition in the northern hemisphere is greater than that in the southern hemisphere.

The seasonal variation of the Sr^{90} is remarkably similar to the seasonal variation of the total ozone in the atmosphere which has been observed by many workers. Based on measurements of the distribution of ozone and water vapour in the atmosphere, Dobson⁶ has proposed a model for the general circulation which offers a satisfactory explanation of the observed Sr^{90} data. In Dobson's model, a very cold pool of air forms above the winter pole during the late winter months when the air lies in shadow. The ultimate sinking of this pool, carrying ozone-rich air to lower levels in the stratosphere, is believed to be the cause of the rapid increase in total ozone in early spring in high latitudes. Since the Sr^{90} concentration in the stratosphere increases rapidly with height¹ this subsidence would also bring Sr^{90} -rich air into the lower stratosphere in early spring, leading to a seasonal variation of the concentration in this region of the atmosphere.

The interchange of air between the stratosphere and the troposphere has been discussed by Brewer⁷ who, in order to explain the form of the water-vapour curve in the stratosphere, has suggested a circulation system in which tropospheric air enters the stratosphere at the equator, travels in the stratosphere to temperate and high latitudes and then sinks again into the troposphere. This circulation provides the means for bringing stratospheric Sr^{90} down into the troposphere where the concentration would be expected to show the seasonal features discussed above. The form of the global deposition curve (Fig. 5b) supports the view that the stratospheric air enters the troposphere in the middle latitudes, bringing with it Sr^{90} which is progressively washed out of the troposphere by rain water as it travels north and south from the region of entry.

Finally, the subsidence of the belt of cold air in the stratosphere above the winter pole would be expected, from continuity considerations, to initiate a meridional circulation in the stratosphere in which there would be a more or less continuous flow from the summer to the winter hemisphere.⁸ This flow might provide the explanation for the presence and deposition in the southern hemisphere of Sr^{90} from clouds which were generated in the northern hemisphere.

9 PRESENT AND FUTURE LEVELS OF Sr^{90} IN U. K. SOIL

Most of the Sr^{90} deposited has fallen since May 1954 and, in considering future levels on the ground, computations will be based on experience since that date. In the successive yearly periods starting in May 1954, the Sr^{90} deposition at Milford Haven has been 2.06, 2.24, and 2.55 mc/km² respectively and the cumulative level in May 1957 was 7.5 mc/km². These annual figures show an increasing trend but since it is unlikely that the controlling meteorological factors remain constant from year to year, a forecast based on the small differences between these figures would be inaccurate and possibly misleading. It is considered preferable to calculate what the future levels of Sr^{90} might be from some simple assumptions about the frequency of nuclear tests in the future. The formulae used are given in Appendix 3.

The simplest assumption to make is that weapons will be tested at such a frequency that the mean ratio of deposition of Sr^{90} will maintain the value it has had in recent years (2.3 mc/km²/year). On this basis the level of Sr^{90} on the ground at Milford Haven will reach an equilibrium value of 92 mc/km² in about 100 years time. In this simple model, no assumption has had to be made concerning the size of the stratospheric reservoir of Sr^{90} .

A second simple model is that in which firing is presumed to cease in the middle of 1957. The size of the stratospheric reservoir is now relevant but this cannot be estimated unless the rate of deposition of stratospheric dust is known. A figure of 12% per year was previously obtained¹ from an extrapolation of the fission product content of the lower stratosphere but this figure cannot be regarded as more than a rough estimate. The results plotted in Fig. 2, showing substantial deposition from the 1954 tests up to 1956 at least, suggest that the rate of deposition is certainly not very high and it would appear to be reasonable to choose an upper limit of 25% per year. With this assumption, the size of the effective stratospheric reservoir, i.e., the total amount of Sr^{90} available for deposition at Milford Haven, may be calculated to be about 10 mc/km² in 1957. If tests now cease, the ground concentration of Sr^{90} at Milford Haven would be expected to increase and pass through a maximum value of 14 mc/km² in 1964. If a deposition rate of 12% per year is used, the maximum value is 18 mc/km², to be reached in 1969.

The last model to be considered is one in which the future rate of injection of Sr^{90} into the stratosphere is assumed to remain constant at the level of the past few years. The actual deposition at Milford Haven during these years has not been consistent with this assumption which would lead to a greater increase from year to year than is actually observed. For this model, therefore, we consider a future test programme in which the amount of Sr^{90} generated per three-year period is equal to that created between the spring of 1954 and the spring of 1957. If the deposition rate is assumed to be 25% per year, this quantity, from the last paragraph and Fig. 2, will be approximately 16.8 mc/km^2 , corresponding to an effective creation rate of $5.6 \text{ mc/km}^2/\text{year}$. With these assumptions, an equilibrium value of about 200 mc/km^2 will be reached in about 100 years. If the deposition rate be assumed to be 12% per year, the ultimate equilibrium level will be approximately 300 mc/km^2 .

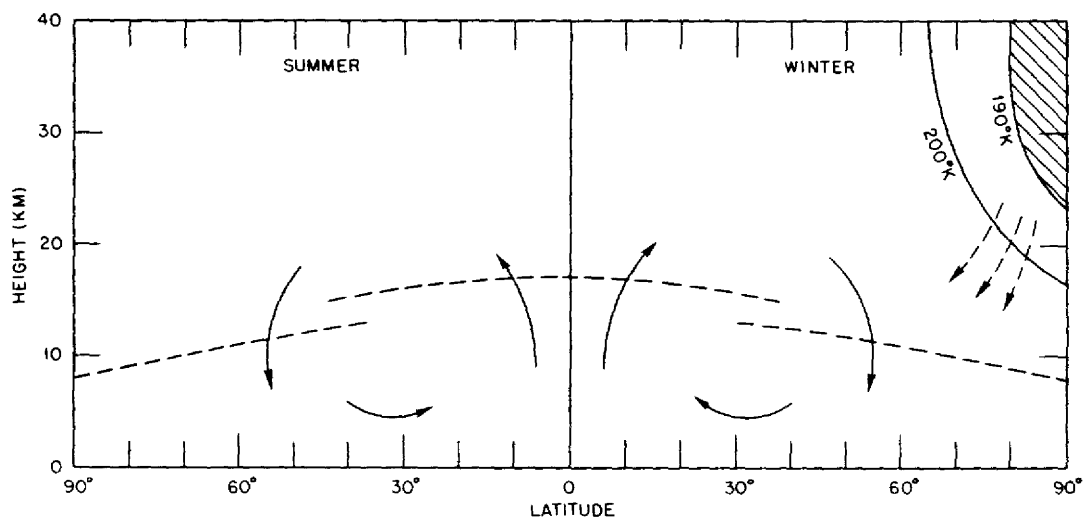

Fig. 7— Atmospheric circulation model (after Dobson and Brewer).

10 CONCLUSIONS

The programme of measurements described has revealed some interesting and important features of the exchange processes between the stratosphere and the troposphere which give rise to a non-uniform deposition pattern of long-lived fission products over the surface of the earth. The relative smoothness of this pattern suggests that with a sufficient number of sampling points it might be possible to obtain reasonable values for the integral of Sr^{90} deposition over the surface of the earth. A summary of the main results is given in the abstract at the front of the report.

In order to forecast future ground-level concentrations from existing data, it is important to distinguish between tropospheric and stratospheric fallout and the differentiation could be improved by reducing the present sampling period from three months and by including one or more short-lived isotopes in the radiochemical analysis. For a given analytical effort, however, such a programme would limit the number of sampling stations which could be operated, and the present arrangement is a fair compromise. Forecasting would also be improved if more information could be gleaned about the size of the stratospheric reservoir of activity. A programme of stratospheric sampling up to 14,000 metres, comparable with that described in HP/R 2017¹ but more sustained, is now being planned in the U. K. In the meantime a programme of Cs^{137} measurement has been started with the gamma-ray spectrometer on air filters which have been collected over the past few years. The object is to study the simultaneous variation of the Cs^{137} concentrations in rain water and in tropospheric and stratospheric air. It is hoped to acquire more data to test the theory which has been advanced for the transfer of fission products from the stratosphere to ground. In this same connection, measurements of the meridional distribution of fission products in the stratosphere would be of interest and, in

particular, measurements of Sr^{90} in the stratosphere at high latitudes at the end of the polar night might confirm the hypothesis that the seasonal increase is due to the subsidence of cold air in those regions.

REFERENCES

1. N. G. Stewart, R. N. Crooks, E. M. R. Fisher, AERE HP/R 2017.
2. R. G. Osmond, A. G. Pratchett, J. B. Warricker, AERE C/R 2165.
3. W. J. Megaw, R. C. Chadwich, AERE HP/M 114.
4. W. F. Libby, *Proc. Nat. Acad. Sci.* 42, 365, (1956).
5. F. J. Bryant, A. C. Chamberlain, A. Morgan, and G. S. Spicer, AERE HP/R 2353.
6. G. M. B. Dobson, *Proc. Roy. Soc. London, A.*, 236, 187, (1956).
7. A. W. Brewer, *Quart. J. Roy. Meteorol. Soc., London*, 75, 351, (1949).
8. W. W. Kellogg, *J. Meteor.*, 9, 446, (1952).
9. F. Möller, *Petermans Geographische Mitteilungen*, 95, 1, (1951).

Appendix 1

THE RELATION BETWEEN THE CONCENTRATION OF Sr^{90} IN THE LOWER ATMOSPHERE AND THE SPECIFIC Sr^{90} CONTENT OF RAIN WATER

An important assumption made in this report is that the specific Sr^{90} activity of rain water is proportional to the concentration of Sr^{90} in the lower atmosphere and, in particular, that the observed seasonal variation of the former (Fig. 3) reflects a similar variation in the latter.

The data given in Sec. 5.2 show that over a long averaging period the specific activity of rain water is fairly constant over the U. K. and is relatively independent of the amount of rain which falls. It is reasonable to deduce from this that the assumed proportionality between the specific contents of air and rain water is valid for long periods of sampling.

A more detailed proof can be obtained by examining the factors which could affect this proportionality, namely dry deposition and the dependence of the specific activity of rain water on the size of showers (Sec. 4). Dry deposition is generally a small factor under conditions of average rainfall and it has been calculated from published data¹ that the ratio of dry deposition to average rain deposition for dust of stratospheric origin (steep gradient in the atmosphere) is only 0.025, using a dry deposition velocity of 0.07 cm/sec (Sec. 4). Thus little error is introduced into the sampling system under average conditions, but the factor increases in inverse proportion to the rainfall. It has been calculated from the rainfall records that the effect of dry deposition on the 1955 peak of Fig. 3 is negligible but that the 1956 peak should be reduced relatively by 7%.

The statistics of the individual showers falling during the sampling periods have been examined and relative corrections made for the corresponding washout efficiencies in accordance with Fig. 1. Again, the correction to the 1955 peak in Fig. 3 is small while the maximum to minimum ratio for the 1956 peak is reduced by 8%.

The deduction therefore is that the 1955 peak reflects the air concentrations faithfully and that the 1956 peak does so to within 15%.

Appendix 2

THE ORIGIN OF THE Sr^{90} DEPOSITED IN THE U. K. AND IN OTHER PLACES REMOTE FROM TEST SITES

1. It is comparatively simple to show that the Sr^{90} deposition in the U. K. is primarily of stratospheric origin. It is generally agreed that tropospheric dust is deposited in a matter of weeks and a mean atmospheric residence time of 31 days has been obtained by measurement.¹ An upper limit can therefore be set to the amount of Sr^{90} of tropospheric origin in a sample by attributing all the observed Sr^{89} to that source, assuming mean age of, say, 35 days, and computing the associated Sr^{90} . It has been shown by this method that tropospheric Sr^{90} contributes less than 5% of the total observed during the 1955 peak period in Fig. 3. In more detail, if one assumes that sample 17 (Table 2), which gave a particularly high $\text{Sr}^{89}/\text{Sr}^{90}$ ratio, was a mixture of 1954 dust and dust from the U. S. spring tests of 1955 and that the latter was 35 days old, the contribution of the 1955 tests can be shown to be only 8% of the total, and this is certainly an upper limit. Similar reasoning can be applied to the more complex 1956 peak and it can be shown that an upper limit to the contribution of tropospheric dust to the total deposited Sr^{90} is 12%.

2. It is possible to demonstrate the importance of old fission products in the rain water studies by examining the $\text{Sr}^{89}/\text{Sr}^{90}$ and $\text{Ce}^{144}/\text{Sr}^{90}$ ratios in Table 2. For fresh fission products these ratios would have values of 154 and 34 approximately and these would decay with half lives of approximately 55 days and 285 days respectively. The ratios in Table 2 are in general much smaller than their theoretical initial values, indicating the presence of old fission products. The highest $\text{Sr}^{89}/\text{Sr}^{90}$ ratio was obtained on sample 38 and the method of para. 1 shows that the short-lived material contributed 45% of the Sr^{90} in this sample; the sample was of low specific activity, however, and the correction serves only to increase the maximum to minimum ratio in Fig. 3.

3. Computations based on the measurement of the gross fission product activity in rain water also argue in favour of the stratospheric origin of the deposited Sr^{90} . The effective age of the fission products in all daily rain water samples has been determined from the slope of the decay curves measured soon after collection. Using the general argument of para. 1, all samples whose effective ages were less than 50 days were selected as of tropospheric origin only and the corresponding amounts of Sr^{90} calculated, using a fission yield of 4%. The result again shows that tropospheric dust has contributed less than 10% of the total Sr^{90} deposited.

4. An argument supporting the hypothesis that the Sr^{90} has its main origin in large-scale nuclear explosions lies in the magnitude of the deposition, which reached a value of 7.5 mc/km^2 at Milford Haven in April 1957. Up to January 1955, it was possible to distinguish between the fission products from the various series of tests with sufficient accuracy to allow the associated Sr^{90} to be calculated. By this means it has been shown that the total amount of Sr^{90} deposited at Milford Haven as a result of all weapon tests in the nominal range of sizes, prior to January 1955, was 0.19 mc/km^2 . Although the exact number of such weapons exploded since then is not known, it is unlikely that they can have contributed more than a few percent of the total Sr^{90} deposited.

This argument can be strengthened by considering the total world deposition of Sr^{90} . By extrapolating the curve of Fig. 5a to zero at the poles, and integrating over the surface of the earth, it has been calculated that the total Sr^{90} deposited in 1956 was 9×10^5 curies. Since the rainfall at each of the measuring stations represented in Fig. 5a is not necessarily representative in amount of the rainfall within its own belt of latitude, a better estimate of the total Sr^{90} deposited per year in recent years can be obtained by combining the specific activity curve of Fig. 5b with the mean annual rainfall in various latitudes⁹ and integrating over the earth's surface as before. The value thus obtained for the annual deposition of Sr^{90} is 6.7×10^5 curies which, assuming a 4% fission yield for Sr^{90} , is the amount associated with the fission products from a 5 MT explosion, or from 2,500 nominal explosions. This number alone suggests that nominal explosions can have contributed a small fraction only of the annual deposition of Sr^{90} in recent years.

Appendix 3

FORMULAE USED FOR COMPUTING FUTURE LEVELS OF Sr⁹⁰ ON U. K. SOIL

Model 1: The future programme is such that the mean rate of deposition of Sr⁹⁰ maintains the value it has had over the past three years (2.3 mc/km²/year).

The mean rate of fallout of Sr⁹⁰ between May 1954 and May 1957 has been 2.3 mc/km²/year, and the cumulative level in May 1957, including pre-1954 material, was 7.5 mc/km². In the detailed model we can make an allowance for this pre-1954 Sr⁹⁰ by supposing that the mean deposition rate of Sr⁹⁰ has been 2.3 mc/km²/year since January 1st, 1954. The level on the ground at any time t (years) since that date is then given by X_g where:

$$X_g = \frac{2.3}{\lambda} (1 - e^{-\lambda t}) \text{ where } \lambda \text{ is the decay constant of Sr}^{90}$$

$$\text{i.e. } X_g \text{ (mc/km}^2\text{)} = 92 (1 - e^{-0.025t}) \quad (1)$$

The equilibrium value of X_g on this model is 92 mc/km².

Model 2: Firing is presumed to cease in mid-1957.

The one unknown factor in this case is the fraction of the stratospheric reservoir deposited per year.

In the most recent complete year of measurement (May 1956 to May 1957) the amount of Sr⁹⁰ deposited at Milford Haven was 2.55 mc/km² and hence the effective stratospheric reservoir, on the assumption that a fraction λ_m of stored Sr⁹⁰ is deposited annually, is given by:

$$X_s = 2.55/\lambda_m \quad (2)$$

If firing be presumed to have ceased in mid-1957, the value of the ground level concentration t years later will be:

$$X_g = 7.5e^{-\lambda t} + \frac{2.55}{\lambda_m} (1 - e^{-\lambda_m t})e^{-\lambda t} \quad (3)$$

X_g has a maximum value given by:

$$X_g(\text{max}) = \frac{(7.5 \lambda_m + 2.55)}{(\lambda + \lambda_m)} e^{-\lambda T} \quad (4)$$

at a time T given by the equation:

$$e^{-\lambda_m T} = \frac{(7.5 \lambda_m + 2.55)}{2.55(\lambda + \lambda_m)} \quad (5)$$

Thus if the deposition rate is 12% per year, $\lambda_m \approx 0.12$ and the ground level concentration will go through a maximum value of 17.7 mc/km² in 1969. Maximum values for other values of λ_m may be calculated from equations (4) and (5).

The rate of deposition at a time t after mid-1957 is given by the expression $2.55 e^{-(\lambda + \lambda_m)t}$. Thus if $\lambda_m = 0.12$ the rate of deposition will fall by a factor of 2 every five years.

Model 3: Future test programme such that the amount of Sr⁹⁰ generated per three-year period is equal to that created between Spring 1954 and Spring 1957.

The total deposited between May 1954 and May 1957 was 6.9 mc/km² at a mean rate of 2.3 mc/km²/year. If, as before, we assume that a fraction λ_m of the stratospheric reservoir

is deposited annually, then the total Sr^{90} on the ground and in the air above Milford Haven, due to explosions since 1954, will be given very nearly by:

$$X_t = 6.9 + \frac{2.3}{\lambda_m} \quad (6)$$

It follows that the mean rate of injection over the past three years will be given by X_0 where:

$$X_0 = \frac{1}{3} (6.9 + 2.3/\lambda_m) \quad (7)$$

If this rate of injection continues, the ground level concentration at a time t years after 1954 will be given by:

$$X_g = \frac{X_0}{\lambda} (1 - e^{-\lambda t}) - \frac{X_0}{\lambda + \lambda_m} (1 - e^{-(\lambda + \lambda_m)t}) \quad (8)$$

The equilibrium value of X_g to be reached in about 100 years time will be:

$$\frac{X_0}{\lambda} - \frac{X_0}{\lambda + \lambda_m} = \frac{2.3 + 6.9 \lambda_m}{3\lambda(\lambda + \lambda_m)} \quad (9)$$

If $\lambda_m = 0.12$, the equilibrium deposit of Sr^{90} derived from equation (9) is 290 mc/km². The rate of deposition at a time t after the beginning of 1954 is given by the expression:

$$\frac{\lambda_m X_0}{(\lambda + \lambda_m)} (1 - e^{-(\lambda + \lambda_m)t})$$

which rises to an equilibrium value of $\lambda_m X_0 / (\lambda + \lambda_m)$. If $\lambda_m = 0.12$, the equilibrium value of 7.2 mc/km²/year will be reached in about twenty years time.

It should perhaps be pointed out that this model is really only applicable to long-term extrapolation since it is not consistent in detail with the observed pattern of deposition throughout the years 1954-1957.

MEASUREMENTS OF Cs¹³⁷ IN HUMAN BEINGS IN THE UNITED KINGDOM*

J. Rundo

U.K.A.E.A. Research Group, Atomic Energy Research Establishment, Harwell

ABSTRACT

A method of determining the radio-caesium content of the human body using thallium-activated sodium iodide crystals and gamma-ray spectrometry is described, and results are presented for subjects measured between June 1956, and July 1957. The potassium content was determined simultaneously and the mean content of 16 adult males was 0.21 per cent of body weight. The mean caesium content of these subjects was 34.0 μc per gram of potassium with a standard deviation of 7.6 μc per gram.

1 INTRODUCTION

The presence of Cs¹³⁷ in the human body was first reported by Miller and Marinelli¹ for American subjects in the second half of 1955 and similar observations for British subjects were first made in the spring of 1956.² A method of calibration of the apparatus at Harwell has been devised and this memorandum describes the method and results obtained to date (mid-1957). We have not made a systematic study of the levels as a function of time or geographical location.

2 TECHNIQUE

The apparatus used consisted of a substantial lead shield with four crystals of NaI(Tl), 1.75 in. diameter by 2 in. thick, placed over the subject at a height of 14 in. above the stretcher. The pulses from the photomultipliers were passed to a linear amplifier (AERE type 1049C) and the spectrum was determined with a 30-channel pulse amplitude analyser (AERE type 1091A). A description of the apparatus in its original form has been given by Owen.³ Some subjects were measured using a single crystal 4.25 in. diameter by 2 in. thick, placed centrally over the body at the same height as the small crystals.

To minimise the risk of observing external contamination on skin or clothing, all subjects showered and changed into previously monitored pyjamas. Each measurement lasted 50 min.

*This paper was received from the Atomic Energy Research Establishment as Report A.E.R.E. HP/M. 126, dated January 1958.

3 CALIBRATION

Since the energy of the gamma-ray emitted by Cs^{137} (0.66 Mev) is less than that of the gamma-ray emitted by K^{40} (1.46 Mev), the spectrum of the radiation from the caesium is superimposed on part of that from the potassium. Determination of the Cs^{137} content requires that the contribution from the K^{40} be known. The potassium content can be determined from the spectrum above the point where caesium contributes (about 0.8 Mev).

A polythene phantom composed of right circular and elliptical cylinders was used for calibration purposes. It was filled with a strong solution of potassium chloride and the spectrum of the radiation was determined in the apparatus; by suitable arrangements of the parts of the phantom the effects of varying weight were determined. The spectrum was broken into four bands, the first two covering the caesium range and the second two covering the potassium range above 0.8 Mev. The sensitivity (expressed as counts per minute per gram potassium) in each band was plotted as a function of phantom weight. The sensitivity for any intermediate weight was determined by interpolation. The band limits and the sensitivity in each band for a phantom weight of 70 kg are shown in Table 1, together with the background, determined with the phantom filled with distilled water.

Table 1 — BACKGROUND AND SENSITIVITY OF THE APPARATUS TO POTASSIUM AND CAESIUM IN A 70 KG PHANTOM

	Approximate band limits, kev			
	I	II	III	IV
	115-525	525-820	820-1300	1300-1600
Background, counts/min	261	76	56	21
Counts/min/gram of K	0.382	0.0678	0.0807	0.0569
Counts/min/ $\text{m}\mu\text{c}$ Cs^{137}	5.65	1.30		

Precisely similar measurements were made with the phantom filled with a weak solution of Cs^{137} and the spectrum was divided into two bands (I and II). The sensitivity (counts per minute per $\text{m}\mu\text{c}$) for a phantom weight of 70 kg is also shown in Table 1. Two estimates of the potassium content of a subject were obtained from the observed counting rates in bands III and IV, and the weighted mean was used to determine the contributions to the counting rates in bands I and II. These were subtracted from the observed counting rates and the differences used to calculate the caesium content. With the background known accurately, the statistical errors were such that the potassium content could be determined with a standard error of about ± 10 g, and the caesium content with a standard error of ± 0.7 $\text{m}\mu\text{c}$ in an observation lasting 50 min. For the measurements made using the single large crystal, the sensitivities to potassium in band IV and to caesium in band II were appreciably higher, while in the other bands they were similar to those in Table 1. As a result the standard error (statistical only) on the potassium content was about ± 7 g, and on the caesium content ± 0.5 $\text{m}\mu\text{c}$.

4 RESULTS AND DISCUSSION

All the results obtained between June 1956, and July 1957, on subjects who have not been occupationally exposed to Cs^{137} , are set out in Table 2. With three exceptions (K.B., J.Be., and R.M.F.) these subjects are resident in Berkshire and Oxon. The results for subjects measured in June 1956 are slightly suspect due to variations in the background at that time.

The mean potassium content of the 16 adult males is 0.212 ± 0.005 per cent of body weight but with a standard deviation of ± 0.023 per cent. The large difference between this standard deviation and the standard error of a single observation (0.010 to 0.015), indicates that there is considerable biological variation. The value for the mean potassium content is consistent with the values obtained by ionisation chamber methods in 1953 and 1954 (Burch and Spiers, 1954; Rundo, 1955; Sievert, 1956)⁴⁻⁶ and with the value reported in 1955 by the use of gamma-ray spectrometry¹ (Miller and Marinelli, 1956); it is slightly higher than the most recent value

PRIVACY ACT MATERIAL REMOVED

Table 2— POTASSIUM AND CAESIUM CONTENTS OF 16 MEN NOT OCCUPATIONALLY EXPOSED TO Cs¹³⁷, MEASURED BETWEEN JUNE 1956 AND JULY 1957

Date measured	Subject	Potassium content		Cs ¹³⁷ content		Comments
		g	% body weight	m μ c	μ c/g of K	
1956						
June 25		153 \pm 17	0.239 \pm 0.026	4.7 \pm 1.2	31 \pm 9	See also Mar. 7, 1957
June 26		168 \pm 18	0.219 \pm 0.023	<8 \pm 1	<48 \pm 8	See also Jan. 22, 1957
June 27		188 \pm 20	0.202 \pm 0.022	4.7 \pm 0.8	25 \pm 4	See also Feb. 19, 1957
June 28		155 \pm 11	0.201 \pm 0.014	4.2 \pm 1.3	27 \pm 9	See also Nov. 22, 1956
Sept. 28		177 \pm 11	0.236 \pm 0.015	6.1 \pm 0.7	34 \pm 4	Resident of Leeds
Nov. 22		159 \pm 5	0.206 \pm 0.007	3.2 \pm 0.4	20 \pm 3	Mean of 2 measurements
Nov. 30		110 \pm 9	0.191 \pm 0.016	4.3 \pm 0.7	39 \pm 7	
Dec. 6		153 \pm 9	0.214 \pm 0.012	5.2 \pm 0.7	34 \pm 5	
1957						
Jan. 22		187 \pm 10	0.244 \pm 0.013	4.7 \pm 0.8	25 \pm 4	
Feb. 15		133 \pm 7	0.183 \pm 0.010	5.3 \pm 0.5	40 \pm 4	
Feb. 21		143 \pm 8	0.181 \pm 0.010	4.4 \pm 0.6	31 \pm 5	
Feb. 19		183 \pm 6	0.198 \pm 0.007	7.1 \pm 0.5	39 \pm 3	Mean of 2 measurements
Feb. 21— Mar. 5		159 \pm 4	0.255 \pm 0.006	4.3 \pm 0.3	27 \pm 2	Mean of 3 measurements
Feb. 20— Feb. 25		158 \pm 4	0.208 \pm 0.005	3.8 \pm 0.3	24 \pm 2	Mean of 3 measurements
Mar. 7		146 \pm 7	0.225 \pm 0.011	6.5 \pm 0.5	44 \pm 4	
Mar. 11		154 \pm 9	0.184 \pm 0.011	5.7 \pm 0.7	37 \pm 5	
Apr. 24		163 \pm 8	0.230 \pm 0.011	6.5 \pm 0.6	40 \pm 4	Australian
May 30		129 \pm 7	0.196 \pm 0.011	5.2 \pm 0.5	41 \pm 5	
June 24		190 \pm 8	0.238 \pm 0.010	8.4 \pm 0.6	44 \pm 4	Londoner
July 22		149 \pm 9	0.186 \pm 0.011	6.5 \pm 0.7	44 \pm 5	
Mean			0.212		34.0	
Standard deviation			0.023		7.6	
Standard error			0.005		1.7	

reported (0.188 \pm 0.006 per cent for 12 men) by this method⁷ (Marinelli, 1957). Because of the biological variation such comparisons are not strictly valid, but there is also the possibility that the method of calibration used at the Argonne National Laboratory gives different results from that used here. American practice has been to administer orally a small quantity of K⁴² and to compare the counting rates in various energy bands obtained *in vivo* with those obtained from a source of the same activity *in vitro*.

The mean value for the Cs¹³⁷ content of the same 16 subjects as above is 34.0 μ c per gram of potassium, with a standard deviation of 7.6 μ c per gram of K. The lowest and highest value observed are 20 and 44 μ c per gram of K, respectively. Miller and Marinelli⁸ reported that there were no substantial changes in the caesium contents between the spring of 1956 and the end of the year. The values for four of their subjects studied systematically ranged from about 33 to about 45 μ c per gram of K.

Anderson et al.⁹ reported an average Cs¹³⁷ content of 5 m μ c for about 250 subjects measured during 1956 in the U.S.A. This is about the same as found here.

Bird¹⁰ reported values of 5 to 8 m μ c for the Cs¹³⁷ content of three subjects resident in Leeds, measured in April 1957, in general agreement with the levels for the same time shown in Table 2. These were a little higher than the results reported by Burch et al.¹¹ for subjects measured between May and October 1956, but the data are too sparse for any definite conclusions to be drawn. Further, in view of the variation of the Cs¹³⁷ content of milk with geographical location (Booker, 1957), comparisons on a regional basis are unjustified.¹²

In conclusion, it may be noted that if the distribution of potassium and caesium in the body differ markedly from uniform, as used in the phantom, then the absolute results may be in error.

REFERENCES

1. C. E. Miller and L. D. Marinelli, *Science*, 124, 122 (1956).
2. J. Rundo, *Brit. J. Radiol.*, Suppl. 7, 125 (1957).
3. R. B. Owen, *Brit. J. Radiol.*, Suppl. 7, 33 (1957).
4. P. R. J. Burch and F. W. Spiers, *Science*, 120, 719 (1954).
5. J. Rundo, *J. Sci. Instr.*, 32, 379 (1955).
6. R. M. Sievert, *Strahlentherapie*, 99 (2), 185 (1956).
7. L. D. Marinelli, *Brit. J. Radiol.*, Suppl. 7, 38 (1957).
8. C. E. Miller and L. D. Marinelli, Argonne National Laboratory Report ANL-5679, 22 (1957).
9. E. C. Anderson, R. L. Schuch, W. R. Fisher, and W. Langham, *Science*, 125, 1273 (1957).
10. P. M. Bird, Thesis, Leeds (1957).
11. P. R. J. Burch, P. M. Bird, and F. W. Spiers, *Brit. J. Radiol.*, Suppl. 7, 128 (1957).
12. D. V. Booker, *Phys. Med. Biol.* 2, 29 (1957).

REMARKS PREPARED BY DR. WILLARD F. LIBBY*

Commissioner, United States Atomic Energy Commission

1 INTRODUCTION

The whole world is concerned over the question of radioactive fallout, particularly that from the testing of nuclear weapons. This has focused world-wide attention on the problem of the effects of radiation, whether it be from atomic fallout or medical X rays, and a field of knowledge formerly known to only a limited group of scientists is becoming a matter of general concern, thought about and discussed by millions of people. The widespread concern may be due to the general fear of the unknown which has always been a basic human instinct. If the knowledge of the effects of radiation and the magnitude of the doses from fallout were more widely known, this would considerably allay the apprehension. So the first problem is the dissemination of the knowledge of fallout and radiation effects which has been gained over the last several years, and it is for this reason that this paper is presented. Last June the Congress of the United States held extensive hearings on radioactive fallout and radiation, and the minutes of these hearings are one of the best sources of information about the whole subject. In addition, a considerable number of articles have been published since last June which present more recent data and considerations. I hope to refer to some of these in the present paper.

Since there is every reason for the information on radioactive fallout and radiation to be known to any interested person, the United States Atomic Energy Commission has the policy of publishing promptly and completely on this subject, and this paper serves this function also. Before beginning a main subject of Radioactive Fallout, I would like to mention a new development which though related is not entirely germane.

During the recent test operations of the U. S. Atomic Energy Commission and the U. S. Department of Defense, in Nevada, Operation Plumbbob, a bomb was fired underground which had no radioactive fallout because its fireball was sealed in molten rock. The fireball consisted largely of vaporized rock which congealed and totally contained the radioactivity. Essentially no radioactivity, even that belonging to such a volatile material as radioactive krypton, escaped to any considerable degree.

The entirety of the radioactive material was found in some 700 tons of rock which had been fused and then cooled and crushed. Apparently the bomb, which had the power of 1700 tons of ordinary chemical explosive, blew itself a bubble of vaporized rock about 55 ft in radius, which had a skin about 3 or 4 in. thick. The shock wave crushed rock out to about 130 ft so the weight of the crushed rock overhead crushed the thin eggshell when it cooled and broke it into fragments. These fragments contain the bomb debris essentially in its entirety. This means it is possible, at least in the small yield range, to contain and eliminate radioactive fallout in certain types of weapons tests. Of course, effects tests where such materials as structures and military equipment are being checked against atomic blast cannot be conducted in this manner, but these tests could conceivably be done with the special type of bomb with reduced radioactivity.

*For delivery before The Swiss Academy of Medical Sciences Symposium on Radioactive Fallout, Lausanne, Switzerland, March 27, 1958.

Thus, it is likely that a technique has been developed which will make possible test operations which contribute much less fallout.

In addition, the nonmilitary applications of atomic explosives, which the underground shot on September 19 last year disclosed, appear to be so promising that for them alone we must continue certain tests in order that these benefits may be available to the human race. For example, in the underground shot, just mentioned, we produced an earth shock which was very revealing to the seismologists in its clarity and sharpness within a considerable distance from the Nevada test site and it is certain now that from atomic detonations we will be able to determine the internal structure and character of the earth with a clarity and detail never possible with earthquake shocks because of their diffuseness in both time and location.

A second possibility is the applicability of nuclear explosions to moving earth, if the fallout hazard can be controlled. Craters produced in the Pacific Islands are convincing testimony of the possibility of making harbors in regions where the local fallout hazard is tolerable. Perhaps with the devices of reduced fallout which are now being developed such applications will be possible in more populated regions.

A third most intriguing possibility is that of shaking and breaking subterranean structures by nuclear shock. The underground detonation, despite its small 1.7 kiloton yield, is estimated to have crushed about 0.4 million tons of rock. It happened that the mountain selected consisted of rather soft rock, but nevertheless it was consolidated and supported its own weight. After the explosion, a sphere 260 ft in radius was crushed so it could easily be mined. It was not rendered radioactive because the radioactivity was contained in thin rock shell mentioned earlier, which weighed only 700 tons and which was visually distinguishable from the ordinary rock and thus can be separated easily. It is clear that this type of application has great promise.

A fourth example is the containment of the heat generated from large atomic explosions in rock structures which are dry and therefore free of the pervasive thermal conductive characteristics of steam and water. This affords a definite possibility for generating atomic power; if detonations, which are large enough to make such power economical, are practical and if the subsequent drilling and removal of the heat by injection of water to produce steam prove to be practical.

A fifth example is the possibility of making radioactive isotopes by surrounding the explosive devices with appropriate materials so that the neutrons which always escape in atomic explosions can be utilized at least in part.

A sixth example is the potential utilization of the radiation and heat of the bomb to cause chemical reactions.

These six possible nonmilitary applications show that nuclear explosions may have peaceful applications of real importance and that the understanding of the phenomena of radioactive fallout is useful not only in conducting a weapons test, but in the promotion of important peaceful applications.

The radioactivity produced by the detonation of nuclear weapons has been extensively studied and reported upon.¹⁻¹⁷ From this work we have learned about the amount of radioactive fallout which occurs, and the mechanisms for its dissemination in a broad and general way. Let us consider a few of these general points.

1. The stratosphere plays an extremely important role for the fallout from megaton yield weapons, and the troposphere is the medium which disseminates the fallout from kiloton detonations; thus, speaking broadly, stratospheric debris is from megaton yield detonations and the tropospheric fallout is from those of lower yield. It is not that the yield of the detonation is determinative, but rather that the altitude to which the fireball arises before its average density is equalized with that of the surrounding air determines the fallout rates. The megaton yield fireballs are so enormous that they stabilize at levels only above the tropopause, the imaginary boundary layer dividing the upper part of the atmosphere, the stratosphere, from the lower part, the troposphere, while the kiloton yield fireballs stabilize below the tropopause. The tropopause normally occurs at something like 40,000- to 50,000-ft altitude, although it depends on season and location. In other words, low-yield bombs fired in the stratosphere would be expected to give the same slow fallout rates as high-yield weapons do when fired in the troposphere, or on the surface if attention is focused on the part of the fallout which does not come down locally to form the oval shaped pattern pointed in the downwind direction.

2. The stratospheric debris descends very slowly, unless, of course, it is so large as to fall in the first few hours. This paper is concerned only with the world-wide fallout, that is, the fallout which does not occur in the first few hours, and excludes the local fallout which constitutes the famous elliptical pattern which is so hazardous because of its radiation intensity, but which in test operations is carefully restricted to test areas. It is worth mentioning in passing that the local fallout may be the principal hazard in the case of nuclear war. Most serious attention should be paid to it in civilian defense programs.

The world-wide fallout from the stratosphere is literally world-wide in that the rate of descent of the tiny particles produced by the detonations is so small that something like ten years or somewhat less probably is the average time they spend before descending to the ground, corresponding to an average annual rate of about 10 per cent of the amount in the stratosphere at any given time. It is not clear as to just how they do finally descend. It seems probable that general mixing of the stratospheric air with the tropospheric air which occurs as the tropopause shifts with season and as is brought about by the jet streams constitutes the main mechanism, and that the descent of the stratospheric fallout is never mainly due to gravity; but rather the bulk mixing of stratospheric air with tropospheric air brings the radioactive fallout particles down from the stratosphere into the troposphere where tropospheric weather finally takes over. This mechanism makes the percentage fallout rate the same for all particles too small to fall of their own weight, and the same as would be expected for gases providing some means of rapidly removing the gases from the troposphere exists, so the reverse process of troposphere to stratosphere transfer does not confuse the issue.

3. World-wide radioactive fallout in the troposphere is restricted to the general latitude of the detonations for the reason that the residence time in the troposphere is about thirty days.¹⁸⁻²¹ The lifetime of fine particulates in the troposphere appears to be determined by the cleansing action of the water droplets in the clouds. For those particulates which are below one micron in diameter, Greenfield²⁰ calculates that the mean residence time of a one micron particle in a typical cloud of water droplets of 20 μ diameter may vary between 50 and 300 hr, but that a particle of 0.04 μ diameter will last only 30 to 60 hr, and that a particle of 0.01 μ diameter will last only 15 to 20 hr. The theory calculates the diffusion due to Brownian motion and says that it is just this motion induced by the collisions with the air molecules which makes possible the contact between the fallout particles and the cloud drops. Since this theory is based on first principles with the single assumption that the fallout particle sticks to the water droplet on impact—an assumption so plausible as to be almost beyond doubt—it is no surprise to learn experimentally that the Greenfield theory appears to be correct.

There is essentially no world-wide fallout in the absence of rainfall; i.e., in desert regions, except for a little that sticks to tree leaves, blades of grass, and general surfaces, by the same type of mechanism Greenfield describes in the case of clouds. Thus we see that it is the moisture in the troposphere which assures the short lifetime of the world-wide fallout particles, and that when the stratospheric air which contains essentially no moisture and therefore has no cleansing mechanism descends into the troposphere, the tropospheric moisture proceeds to clean it up. On this model, we see that for submicron fallout particles, weather phenomena are controlling, and that the bombs which have insufficient energy to push their fireballs above the troposphere will have their world-wide fallout brought down in raindrops in a matter of about a month, in extreme contrast with the stratospheric material which apparently stays aloft for something like ten years on the average. The contrast between these two lifetimes means that the concentration of radioactive fallout in the stratospheric air in terms of equal densities of air is always much higher than in tropospheric air. This has been experimentally observed to be true.²² In fact, the stratospheric content is about one hundred-fold higher than that of the troposphere corresponding to the much longer stratospheric residence time. Later in this paper new data on the fallout content of the stratosphere are given.

It is inherent in the Greenfield mechanism that the total world-wide fallout will be proportional to rainfall if other factors are not allowed to vary. Thus we find that the Mediterranean basin² affords a good example of the truth of this principle. Other regions are the Northeastern United States, the Southeastern United States, the Northwestern United States and the Southwestern United States.²³ It is now well established that desert areas have very little fallout.

4. After falling to the ground in the form of rain or being picked up on the surface of the leaves of grass or trees by the same type of Brownian motion accretion mechanism causing

cloud drop pick up, the radioactive fallout may enter the biosphere by normal biological processes. Radioactive Sr^{90} and radioactive Cs^{137} are the two principal isotopes which have this facility and are produced in high yield by the fission reaction and are of long enough lifetimes to be disseminated world-wide particularly by the stratospheric mechanism, about 28 years half life for each. Strontium-90 is produced at a level equivalent to about 1 mc of Sr^{90} per square mile of the earth's surface for every two megatons of fission energy, and radiocesium is produced at about 50 per cent higher yield. Of the two isotopes, Sr^{90} , because of its chemical similarity to calcium, collects in human bone, where it is held for years and where its radiations might then cause deleterious effects to the health of the individual, such as leukemia or bone cancer. It is interesting that Sr^{90} constitutes a relatively less important genetic hazard because of the short range of its radioactive radiation and the fact that it is not held in the reproductive organs. Radiocesium stays in the human body only six or eight months on the average, because it has no permanent structure like the bone for which it has a natural affinity. As a result, the amount of radiation occurring from internally ingested radiocesium is much less and most likely is subject to palliative measures calculated to reduce its time in the body. Strontium-90 taken into the bone, however, appears to be stored for many years, the exact time not being known very well.²⁴

Radiostrontium is taken into the body because of its similarity to calcium, but there is a definite difference in chemical behavior which causes animal organisms to prefer calcium. Thus the radiostrontium content of newly deposited bone calcium is less than that for food calcium. In many countries, the principal source of calcium is milk products, so the fact that cow's milk has only one-seventh the strontium in it per gram of calcium that the cow's food has, and that milk taken into the human body similarly deposits calcium in the bones with only half the Sr^{90} content of the milk itself means that human beings naturally have a lower Sr^{90} -to-calcium ratio for new bone than for the food source by something like a factor of 15 for dairy products. On the other hand, vegetation containing Sr^{90} also deposits its strontium relatively inefficiently with a factor of something like 4 less strontium in the bone from these sources than is carried in the vegetable food itself, all relative to calcium. In some countries where calcium in the human diet comes principally from vegetables other sources of calcium contribute, some of which contain essentially no Sr^{90} , namely sea food. Because fallout is diluted so quickly by the action of the waves in the ocean, the concentration of the radioactive strontium in the sea calcium is very much lower than it is in the soil of the land in which the grass and vegetable crops grow. This difference becomes even larger when the effects of direct leaf and stem base pick up are considered. This perhaps accounts for the high values reported by Ogawa²⁵ for rice in Japan. So, fish from the sea are naturally at the lowest level in radiostrontium and sea food should be the lowest source of calcium among ordinary human foods. With all of these factors taken together, the world populations assimilate calcium at a much lower radiostrontium content than is exhibited by land plants to a very considerable degree. Eckelmann, Kulp and Schulert^{10b} have given a detailed sample calculation recently, based on their extensive measurements on human bone.

5. The biological hazard from the radioactive fallout from weapons testing is not well known, and like many biological problems the determination of the hazard in any exact way seems to be almost impossibly difficult. Fortunately, however, it is possible to compare the radiation from radioactive fallout with the intensities of natural radiation to which we are always exposed. For example, it is clear that the present level of the radiostrontium in the bones of young children which are, of course, closest to being in equilibrium with the fallout, since adults have had their bones some time even before there was any radioactive fallout, is about 2 mr/year as compared to an average natural dosage of 150 to 200 mr/year, about 1 to 2 per cent of the dosage from natural sources to the bones depending upon location. Natural radioactivity present in the ground, building materials and even in our own bodies gives us an average total dose at sea level of about 150 mr/year, and medical X-rays add something like another 150 mr. The radiocesium taken into the body and the penetrating radiations from non-assimilable radioactive fallout contribute perhaps another three or four per cent to the whole body dosage. Thus the total dosage to freshly formed human bone is at most five per cent of the natural dosage. Furthermore, we do know that the variations in natural background dosages from place to place are enormous in magnitude as compared to the average value, and of course as compared to the fallout dosage. For example, it has been found²⁶ that exposure rates from

external radiation rise from a value of about 100 mr/year at sea level to something like 230 mr/year at 5000 to 6000 ft altitude in the United States. These numbers are considerably larger than those expected on the basis of earlier calculations and measurements,^{7,27,28} the increase apparently being due to the cosmic rays and their increase with altitudes.²⁹ In addition, the effects of radioactivity in the soil and in building materials made of stone or soil are considerable, amounting in some instances to 50 or 100 per cent of the average natural background dose at sea level, and the magnitude of the medical exposures to X-rays approximates on the average those due to all natural sources.³⁰

We see, therefore, that whatever the extent of our ignorance of the biological effects of radiation, we do know that these effects are not unexperienced by the human species, even from the genetic point of view, since it is clear now that persons living at high altitudes on granitic rocks always have received extra radiation many times greater than is contained in the radioactive fallout from the testing of nuclear weapons, and that even those living on certain sedimentary rocks at sea level always have received about 10 to 20 times the present fallout dose.

Of course, this does not mean that any of the effects from radioactive fallout are in any way negligible and it does not mean that certain numbers of people will not be injured by radioactive fallout radiations, even though these numbers be very small relative to the total population of the world. However, the problem is bounded, and common sense and good judgment can be brought to bear on the extent of the biological hazards even though they are not now known exactly, and probably will not be well understood for many years. Researches to increase this understanding are being done, especially in the United States and United Kingdom and other countries. Information on radioactive fallout and all of its aspects, both physical and biological, is collected and collated by the United Nations' Scientific Committee on the Effects of Atomic Radiation, which is drafting its first report at the present time.

6. From our study of radioactive fallout from testing, we have learned much of value about the circulation of the atmosphere of the world, and we have much more to learn as the study continues, particularly in the stratosphere by balloon and aircraft sampling techniques being carried out principally in the United States at the present time. As we undertake the problem of locating the fallout in the oceans, we undoubtedly will learn much of interest to oceanographers about the circulation of the water in the seas.

7. From our understanding of radioactive fallout from tests, we are the better able to devise methods of civilian defense against fallout in the case of nuclear war, and widespread popular interest in the potential possible hazards from radioactive fallout from nuclear tests has led to a considerable understanding on the part of the general public of these strange phenomena. From this debate and study may come the protection for millions in case nuclear war should occur.

Understanding of the nature of the mechanism by which radioactive fallout is disseminated has led to the reduction of the offsite fallout from testing. We know now that bombs placed upon the ground produce relatively more local fallout and therefore less world-wide fallout. It seems likely that firing on the surface of the sea has a similar, though probably considerably less marked effect.

2 RECENT DATA AND THEIR IMPLICATIONS

Figure 1 of this paper and additional Figs. 1, 2, 9, 10 and Tables 1 and 44 of Part 1 and Table 50 of Part 2 of this volume are up-to-date versions of earlier publications. The most recent results are given for the fallout observed for rainfall collections, for the Sr⁹⁰ content of milk (fresh and dry), for human bone, and for animal bone. It is particularly interesting to note that the data continue to show the principal features noted previously and that little new in principle has appeared.

The tables mentioned above show the data for the HASL pot program, Lamont bone program, and the HASL pasture program. The figures appearing in Volume 1, referred to above, present data on HASL pots, Pittsburgh rainfall, New York City milk, and HASL powdered milk.

Figure 2 shows preliminary data on the stratospheric content of Sr⁹⁰. The data are preliminary for the reason that the air filter efficiencies are unknown at the present, although estimated to be something like 25 per cent. The samples are taken by pumping stratospheric air through filters which are then analyzed. It is clear that, even though an enormous scatter

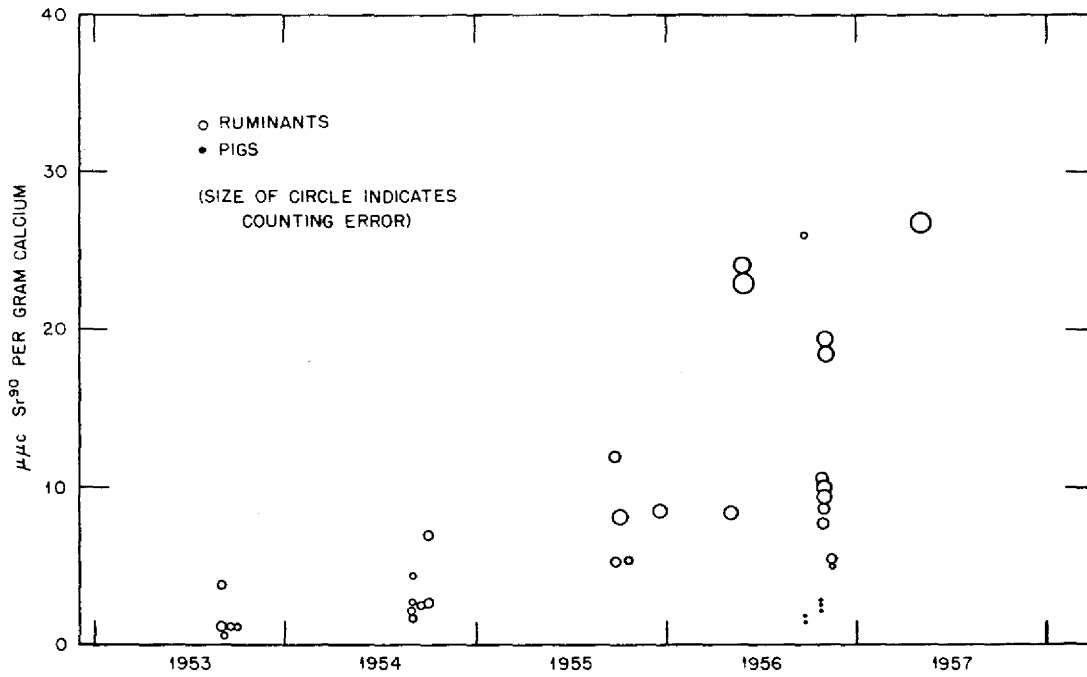

Fig. 1—Strontium-90 in animal bone.

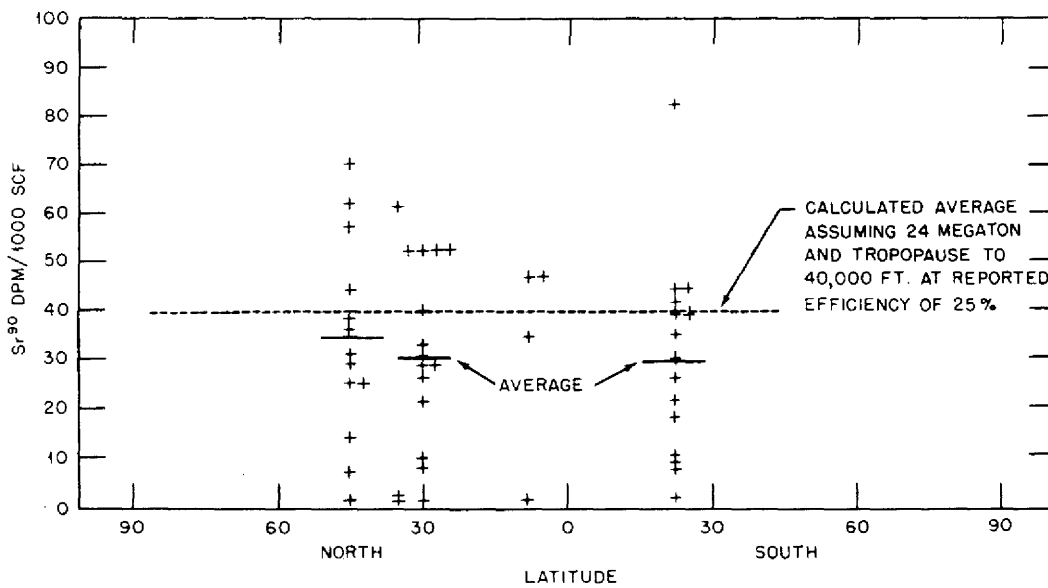

Fig. 2—Stratospheric Sr⁹⁰ content.

is present for reasons of time and experiment, there is no large variation in the stratospheric content of Sr^{90} between the latitude of 30°S and the Northern Hemisphere. Since most of the megaton yield explosions have occurred in the northern latitudes, though the Pacific Testing Grounds are only 11° north of the equator, it appears that this evidence argues for rapid north and south mixing in the stratosphere. As we shall see later, other evidence in the dissemination of nonradioactive carbon dioxide derived from the combustion of fossil fuels³¹⁻³⁵ and of the dissemination of bomb derived radioactive C^{14} seems to confirm this.³⁶⁻³⁸ It is interesting to note also that the actual content of the stratosphere is not in disagreement with the estimates given earlier,⁴⁻⁶ although the value of the filter efficiencies remains to be settled, and it is estimated at the efficiency of about 25 per cent on evidence assuming homogeneity of the particle size. Experiments are now underway to settle the point.

In the model previously advanced,⁴⁻⁶ it is proposed that material introduced into the stratosphere is mixed immediately horizontally to a uniform concentration and has a residence time of 10 years. Further, it is assumed that the latitudinal spread of tropospheric bomb clouds is only 10° with a sharp step function rather than a normal error curve distribution. The bomb debris is arbitrarily assigned to the stratosphere except for 1 per cent tropospheric in the case of megaton yields. Local fallout is assumed to be 80 per cent for land surface shots, 20 per cent for surface water shots, and 10 per cent for air shots. All kilo yield shots are assigned to the troposphere. On these very simple bases we are then, from classified data about the magnitudes and nature of the explosions, able to estimate the total fallout for any place on earth if the deposition from the troposphere is assumed to be proportional to the rain content at a given location. Figure 3 gives such a theoretical latitudinal fallout profile for world-wide fallout as of December 1957, neglecting rainfall variation, and Fig. 4 is the corresponding world map. Figure 5 gives the corresponding timewise variations in the northern latitudes and compares them with the rainfall fallout curves for Milford Haven in England.³⁹ Figure 6 gives a similar comparison for Chicago and Pittsburgh. Curves for other latitudes are given in Figs. 7 and 8. Figure 9 gives the estimated stratospheric reservoir and the expected composition in Sr^{89} versus time. If a further assumption is made, namely that the proportion of the fallout in a given location is given by the ratio of the rainfall to the world-wide average, 0.77 m,⁴⁰ it is possible to compare the detailed fallout observed by the pot collection programs in various localities with the theoretical predicted values given in Table 1, Part 1.

On the basis of these comparisons and in the absence of conclusive evidence as to the age of radioactive fallout, it appears that the simple theory outlined explains the known information within the experimental error. It may develop when more reliable data are available on the age of fallout through the use of short-lived, 12.8 day half-life Ba^{140} fission product, that a mechanism by which a sort of concentrated leaking from the stratosphere occurs at a latitude of about 40° or more may be proved or disproved. At the present time the observed extreme concentration may be explained as being due to coincidence of the tropospheric fallout from the U. S. and Russian tests. If this theory is correct, the Ba^{140} content in periods of high fallout will show that the fallout is young. It is to be hoped that these data will be forthcoming soon.

Machta,^{1,41} and Stewart, Osmond, Crooks and Fisher³⁹ have stated that meteorological considerations and likely stratospheric wind patterns, together with evidence that the $\text{Sr}^{89}/\text{Sr}^{90}$ ratio of the fallout shows the fallout to be old, have led them to the conclusion that the heavier fallout observed in the 40° to 50°N latitude band is stratospheric and not tropospheric in origin as proposed here. The issue still seems to be unsettled since the radiochemical difficulties of the determination of the $\text{Sr}^{89}/\text{Sr}^{90}$ ratio are large and may well have introduced sizeable errors into some of the reported values for this number and since it apparently is possible to account reasonably well for the observed fallout distribution on the present uniform stratospheric fallout theory as shown in the present paper. The critical difference between the two theories is in the matter of the age of the fallout. Better and more significant results probably will be available soon using the $\text{Ba}^{140}/\text{Sr}^{90}$ ratio which for both radiochemical and lifetime reasons is more suitable than $\text{Sr}^{89}/\text{Sr}^{90}$. Ba^{140} has a half life of 12.8 days which is more appropriate to distinguishing between an expected fallout age of perhaps 30 days on the one hand and of about 1 to 2 years on the other, than is the Sr^{89} half life of 51 days. The radiochemical procedure for Ba^{140} is very similar to that for Sr^{90} and both are more sensitive and reliable than the Sr^{89} procedure which is particularly susceptible to errors from radioactive impurities such as other fission products which may have been imperfectly separated. Both Ba^{140} and Sr^{90} are measured by

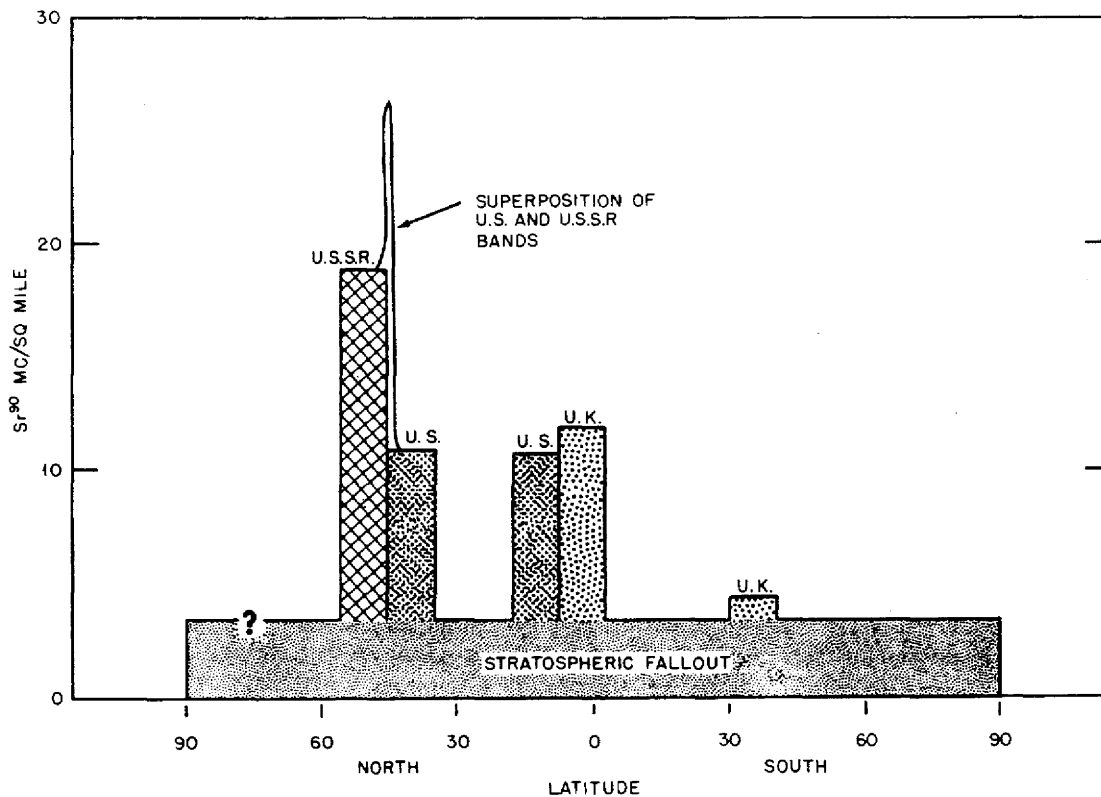

Fig. 3—Theoretical latitudinal fallout profile, December 1957.

short-lived radioactive daughters of characteristic half life and which can be repeatedly removed and measured since a new supply is grown into equilibrium each time a separation has been made.

The importance of settling this point is obviously considerable for both meteorology and geophysics and certainly for the understanding of the mechanism of radioactive fallout. Perhaps the Ba^{140} data will show the truth to lie somewhere between the two mechanisms.

Bomb C^{14}

Rafter³⁷ and Rafter and Fergusson³⁸ have shown C^{14} increases in surface air at Makara in New Zealand and in New Zealand woods and ocean carbonate as shown in Fig. 10. This additional C^{14} is due to bomb generated neutrons which react with air nitrogen to produce it. They find about 2.1 per cent increase per year.

Williams³⁸ of Humble Oil and Refining Company, finds 3.0 ± 9.5 per cent per year in Texas tree rings, Fig. 10, and de Vries⁴² in Holland, and Munnich⁴³ in Heidelberg, Germany, both report increases. The C^{14} increase in the flesh of the land snail, *helix pomatia*, amounted to 4.3 per cent between November 1953 and June 1957 in Holland, while an increase of about 10 per cent during 1955 and 1956 occurred in Heidelberg in various biosphere samples.

At a rate of 2.5 neutrons per 200 Mev of energy release, one megaton would generate 3.2×10^{26} C^{14} atoms. The best estimate, keeping in mind that a substantial amount falls back as calcium carbonate, would be that about 10^{28} C^{14} atoms have been introduced into the atmosphere, mostly into the stratosphere. The estimate of 2.5 neutrons per 200 Mev energy released is higher than an earlier estimate based on an assumed 15 per cent escape efficiency,⁴⁴ the later value being based on firmer information. It also attempts to weigh fusion and fission as they have actually occurred.

About 9.4×10^{27} C^{14} atoms are normally present in the stratosphere due to cosmic ray production.⁴⁵ This figure assumes 22 per cent of the atmosphere to be in the stratosphere. Therefore, with world-wide stratospheric circulation, the rise in the stratosphere should be about 100 per cent as was found in a few measurements made on samples collected in October 1956. Further measurements are in progress.

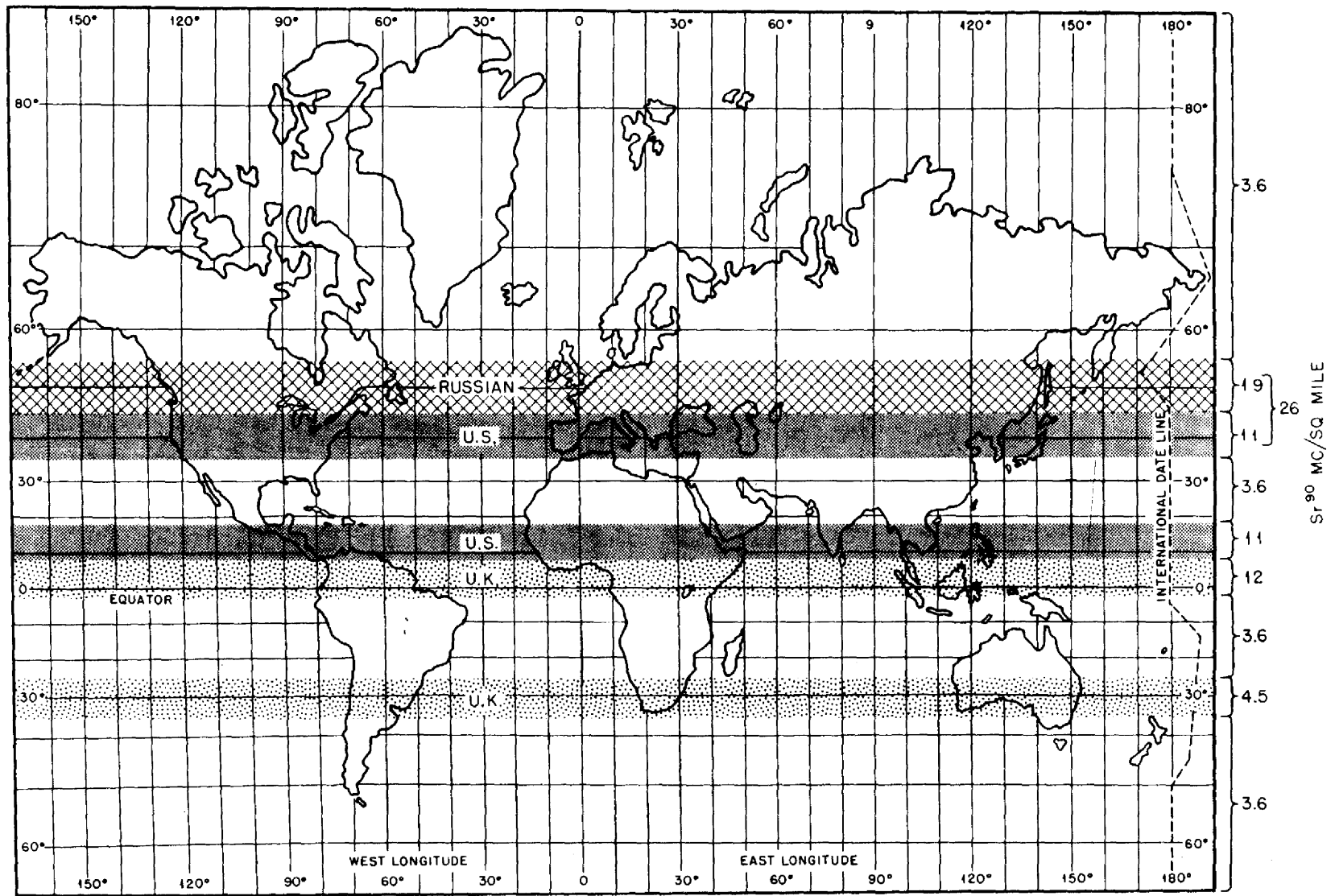

Fig. 4—World fallout map (at end of 1957).

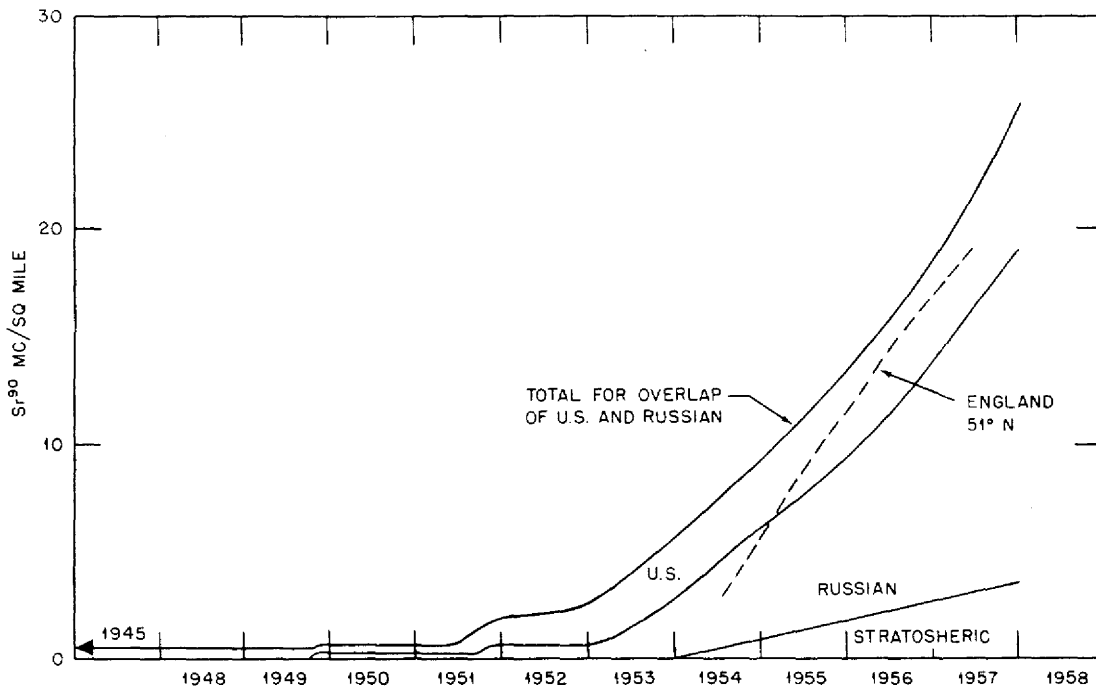

Fig. 5—Predicted vs. observed Sr⁹⁰ fallout curves; total fallout 45°N–55°N (northern U. S. and England).

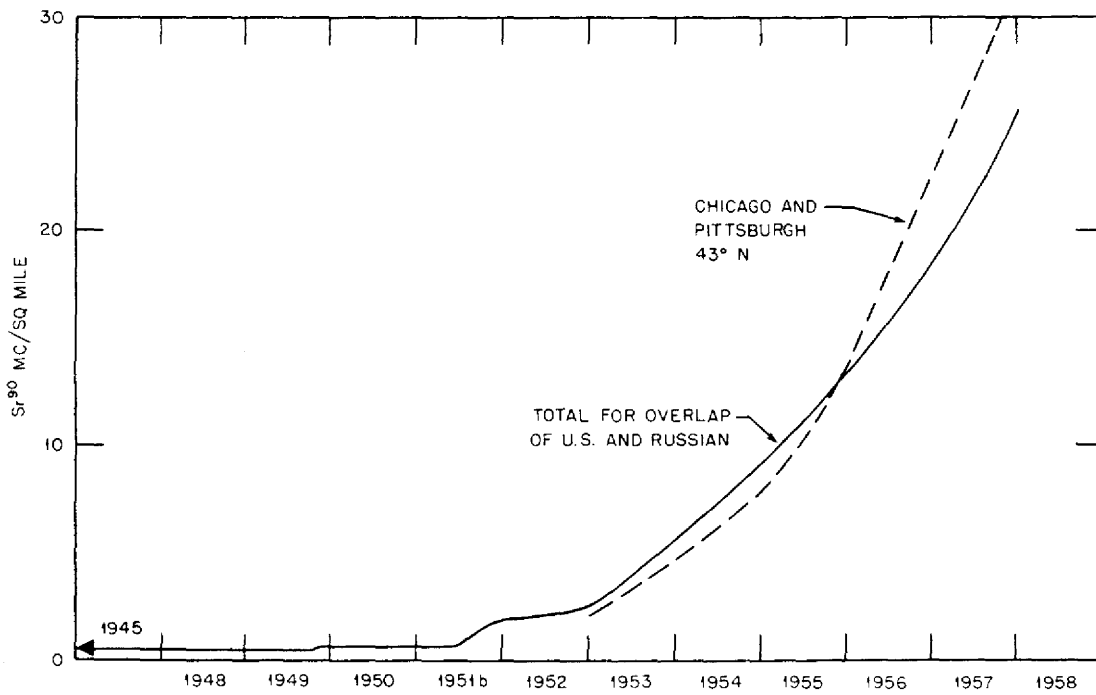

Fig. 6—Predicted vs. observed Sr⁹⁰ fallout curves; total fallout 45°N (northern U. S.).

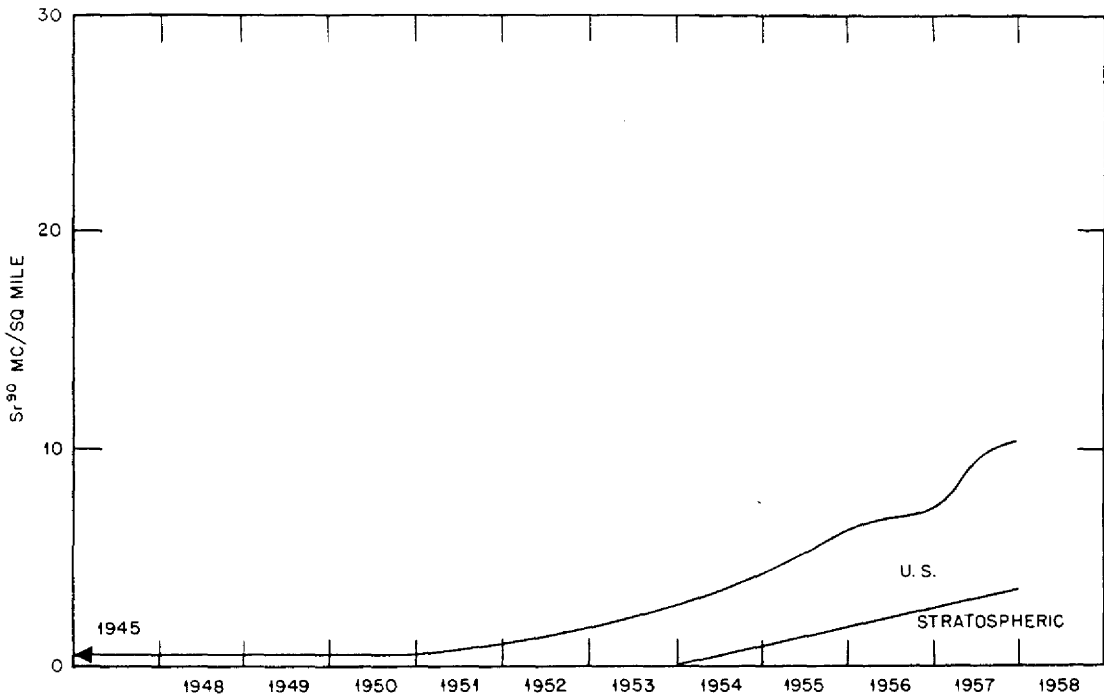

Fig. 7—Predicted Sr⁹⁰ fallout curve; total fallout 35°N-45°N.

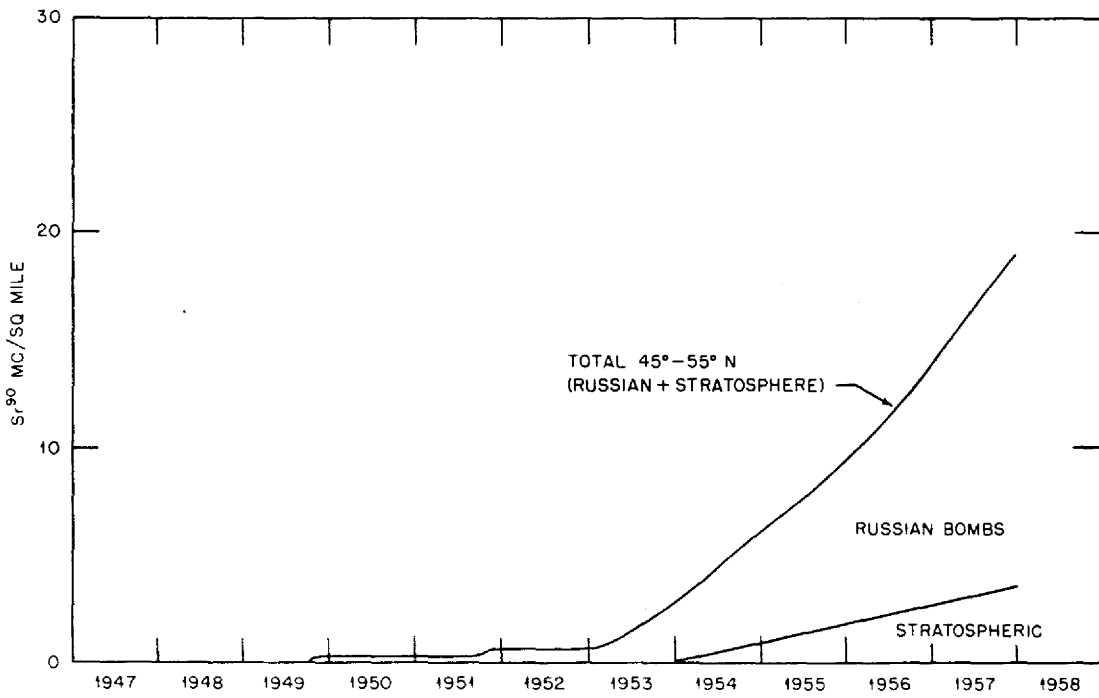

Fig. 8—Predicted Sr⁹⁰ fallout curves; total fallout 45°N-55°N.

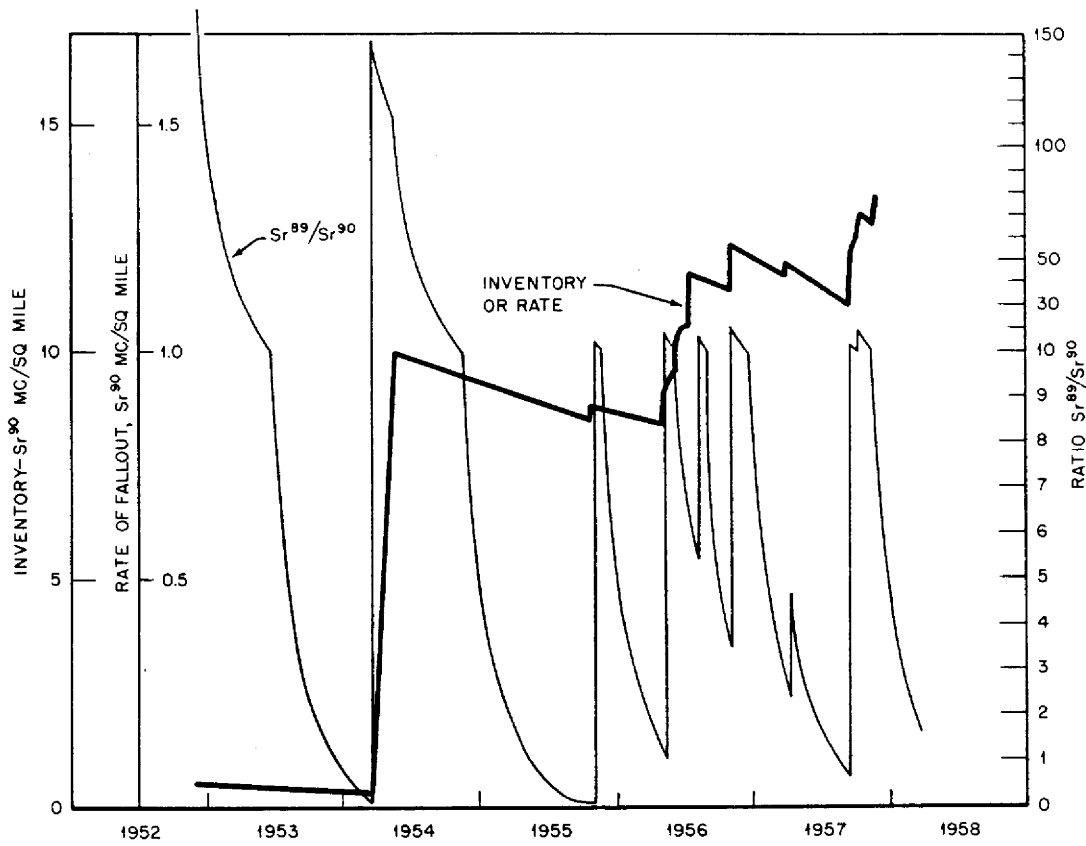

Fig. 9—Stratospheric inventory and rate of fallout; also Sr^{89}/Sr^{90} ratio.

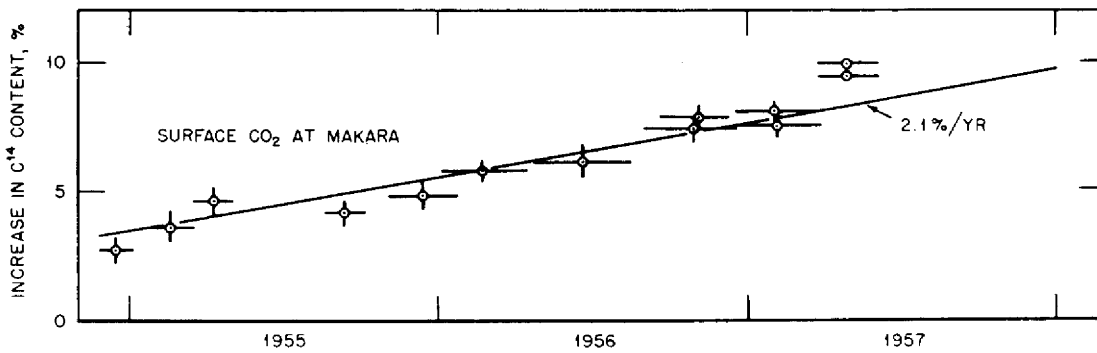
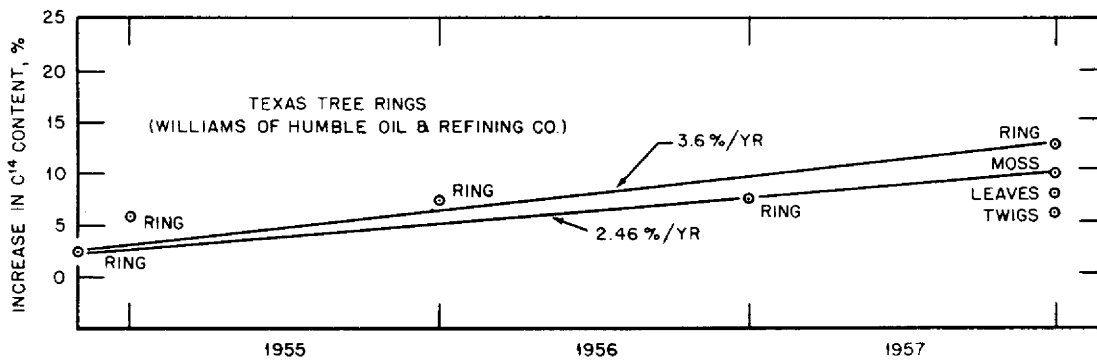

Fig. 10—Bomb C^{14} effect.

In the troposphere in the three years since the 1954 Castle test at the 10 per cent per year figure used for fallout, about 3×10^{27} C^{14} atoms should have descended, or about 1×10^{27} C^{14} atoms per year. The average C^{14} inventory in the troposphere is 3.3×10^{28} without including the ocean or biosphere, so the observed C^{14} rise might be as high as 3 per cent per year as appears to have been observed.

If mixing with the biosphere and top ocean above the thermocline occurred immediately, according to Arnold and Anderson³⁵ who gave 0.2 g/cm² in the top 100 m of the ocean, the total tropospheric reservoir would be 7.5×10^{28} giving an expected rate of increase due to the bombs of 1.3 per cent per year which is in fair agreement with the observations if we assume the mixing with the ocean and the biosphere, particularly the former, is not quite instantaneous.

The main points are that the ratio of the Northern to Southern Hemisphere effect here is not enormous and fits fairly well with the notion that stratospheric gases have a residence time not too different from that of the ultra fine world-wide fallout particles.

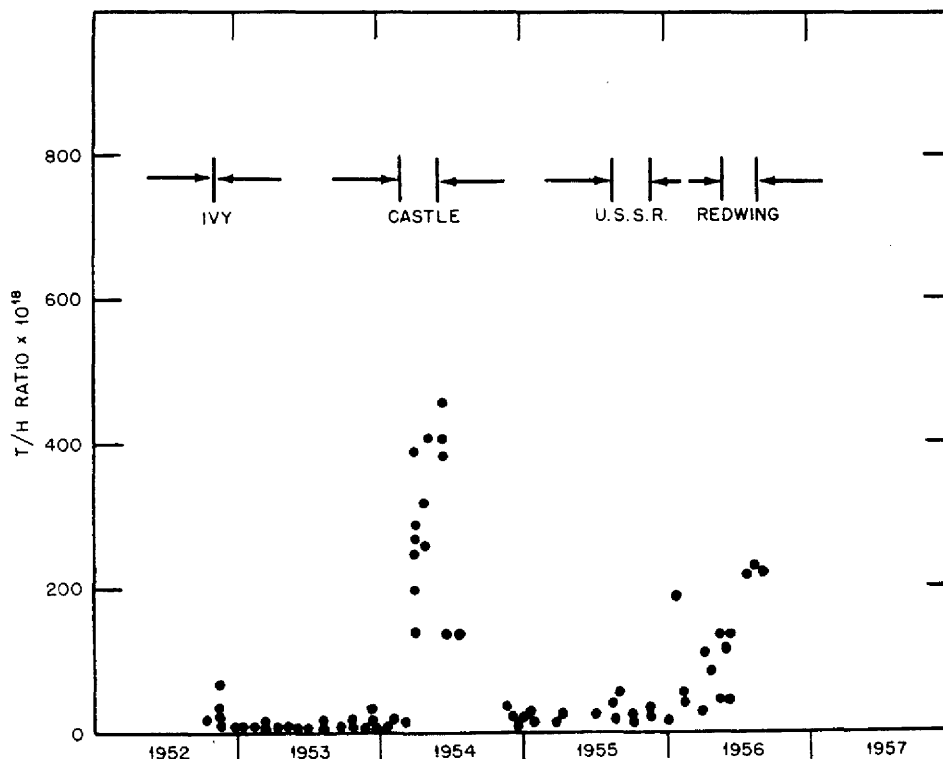

Fig. 11 — Tritium in rain and snow.

In addition, Fergusson³¹ has recently found in studying fossil CO_2 and its effect on reducing the C^{14} content of the biosphere that the mean life of a CO_2 molecule before being absorbed from the tropospheric air into the oceans and biospheres is perhaps two years and that north to south mixing of the fossil CO_2 occurs in less than two years.

Consequently, it seems clear that the ten year residence time for stratospheric gases before descent into the troposphere seems to fit data for C^{14} from bombs as well as the Sr^{90} and Cs^{137} fallout data.

Figure 11 gives up-to-date data on the occurrence of tritium in rain water in the Chicago area.^{21,46,47} It is clear that whereas Sr^{90} and probably C^{14} remain in the stratosphere for years, the tritium from high yield thermonuclear detonations does not, but descends in a matter of 1 or 2 months. This most probably is due to the enormous mass of water carried into the stratosphere by the fireballs of detonations in the moist tropospheric air. The characteristic white mushroom cloud is evidence of the formation of ice crystals in the cold stratospheric air, which if large enough to be seen in this way must certainly be large enough to fall into the troposphere where they melt and join in the ordinary phenomena; i.e., fall out as rain or snow.

Thus a large fractionation relative to fission products and radioactive carbon dioxide occurs. Of course, there probably is some entrainment of fission products on the surfaces of the falling ice crystals by the Greenfield Brownian motion accretion mechanism. In fact, it is known that about 1 per cent of megaton yield off-site fallout occurs in the early banded tropospheric manner. This may be due to this entrainment and thus one would expect that the latitudinal distributions of early tropospheric fallout of both fission products and tritium water from megaton yield bombs fired in the troposphere¹¹ should be identical. No satisfactory data are now available to check this point. In the calculations in this paper the figure of 1 per cent for tropospheric contribution from megaton yields has been used.

3 CONCLUSION

The more recent data, particularly on bomb C¹⁴, when taken together with the earlier data on bomb fission products and tritium, give us some confidence in our present understanding of the fallout mechanism. All of these observations and considerations afford unprecedented opportunities for the study of meteorology and geophysics, particularly in an international cooperative effort such as the International Geophysical Year.

REFERENCES

1. Hearings before the Special Subcommittee on Radiation of the Joint Committee on Atomic Energy, The Nature of Radioactive Fallout and Its Effects on Man, May 27-29, June 3-7, 1957, Parts 1 and 2. U. S. Government Printing Office, Washington, 1957.
2. E. A. Martell, Project Sunshine Bulletin #12, August 1, 1956, AECU-3297(Rev.).
3. E. A. Martell, The Chicago Sunshine Method, May, 1956, AECU-3262.
4. W. F. Libby, Radioactive Strontium Fallout, *Proc. Natl. Acad. Sci.* 42, 365-90 (1956).
5. W. F. Libby, Current Research Findings on Radioactive Fallout, *Proc. Natl. Acad. Sci.* 42, 945-56 (1956).
6. W. F. Libby, Radioactive Fallout, *Proc. Natl. Acad. Sci.* 43, 758-75 (1957).
7. W. F. Libby, Dosages from Natural Radioactivity and Cosmic Rays, *Science* 122, 57-8 (1955).
8. Merril Eisenbud and J. H. Harley, Radioactive Fallout in the United States, *Science* 121, 677-80 (1955).
9. Merril Eisenbud and J. H. Harley, Radioactive Fallout through September 1955, *Science* 124, 251-55 (1956).
- 10a. J. L. Kulp, W. R. Eckelmann, and A. R. Schulert, Strontium-90 in Man, *Science* 125, 219-25 (1957).
- 10b. J. L. Kulp, W. R. Eckelmann, and A. R. Schulert, Strontium-90 in Man, II, *Science* 127, 266-74 (1958).
11. L. Machta, R. J. List, and L. F. Hubert, World-wide Travel of Atomic Debris, *Science* 124, 474-7 (1956).
12. "World-wide Effects of Atomic Weapons, Project Sunshine," August 6, 1953, R-251-AEC (amended).
13. F. J. Bryant, A. C. Chamberlain, A. Morgan, G. S. Spicer, Radiostrontium in Soil, Grass, and Bone in U.K.: 1956 Results, AERE HP/R 2353 (1957).
14. The Hazards to Man of Nuclear and Allied Radiations, British Medical Research Council (1956).
15. Y. Hiyama, A Measure of Future Strontium-90 Level from Earth Surface to Human Bone, *Gakujutsu Geppo* 10, 27-43 (1957).
16. Y. Hiyama, Radiological Data in Japan II, *Gakujutsu Geppo* 10, 1-17 (1957).
17. E. Dahl, The Dangers from Fallout of Strontium-90 after Atomic Bomb Explosions, *Tek. Ukeblad* (July 1957).
18. N. G. Stewart, R. N. Crooks, and E. M. R. Fisher, The Radiological Dose to Persons in the U.K. Due to Debris from Nuclear Test Explosions Prior to January 1956, AERE HP/R 2017 (1956).
19. O. Haxel and C. Schumann, Selbstreinigung der Atmosphäre, *Z. Physik* 142, 126-32 (1955).

20. S. M. Greenfield, Rain Scavenging of Radioactive Particulate Matter from the Atmosphere, *J. Meteorol.* 14, 115-25 (1957).
21. Haro von Buttlar and W. F. Libby, Natural Distribution of Cosmic Ray Produced Tritium II, *J. Inorg. & Nuclear Chem.* 1, 75 (1955).
22. N. G. Stewart, R. N. Crooks, and E. M. R. Fisher, The Radiological Dose to Persons in the U.K. Due to Debris from Nuclear Test Explosions, AERE HP/R 1701, (1955).
23. W. R. Collins and N. A. Hallden, A Study of Fallout in Rainfall Collections from March through July 1956, April 30, 1957, NYO-4839. J. H. Harley, E. P. Hardy, Jr., G. A. Welford, I. B. Whitney, M. Eisenbud, Summary of Analytical Results from the HASL Strontium Program to June 1956, August 31, 1956, NYO-4751. J. H. Harley, E. P. Hardy, Jr., I. B. Whitney, and M. Eisenbud, Summary of Analytical Results from the HASL Strontium Program July through December 1956, NYO-4862.
24. W. F. Neuman and Margaret W. Neuman, Chemical Dynamics of Bone Mineral, Monograph, University of Chicago Press (1958).
25. I. Ogawa, Fallout and Rice Contamination in Japan, *Bull. Atomic Scientists* 14, 35 (1958).
26. L. P. Solon, W. M. Lowder, A. V. Zila, H. D. LeVine, H. Blatz, and M. Eisenbud, External Radiation Measurements in the United States, *Science* (In press).
27. P. R. J. Burch, *Proc. Phys. Soc.*, 67A 421 (1954).
28. H. V. Neher, Gamma Rays from Local Radioactive Sources, *Science* 125, 3257 (1957).
29. The Biological Effects of Atomic Radiation, *National Academy of Sciences* (1956).
30. B. P. Sonnenblick, Aspects of Genetic and Somatic Risk in Diagnostic Roentgenology, *Jour. of Newark Beth Israel Hosp.*, Newark, N. J. VII, 2, 81 (1957).
31. G. J. Fergusson, Reduction of Atmospheric Radiocarbon Concentration by Fossil Fuel Carbon Dioxide and the Mean Life of Carbon Dioxide in the Atmosphere, *Proc. Royal Soc. (London)*, Series A 243, 561-74 (1958).
32. H. E. Suess, Radiocarbon Concentration in Modern Wood, *Science* 122, 415 (1955).
33. H. Craig, Natural Distribution of Radiocarbon and the Exchange Time of CO₂ between Atmosphere and Sea, *Tellus* 9, 1 (1957).
34. R. Revelle and H. E. Suess, Carbon Dioxide Exchange between Atmosphere and Ocean, and the Question of an Increase of Atmospheric CO₂ during the Past Decades, *Tellus* 9, 18 (1957).
35. J. R. Arnold and E. C. Anderson, The Distribution of Carbon-14 in Nature, *Tellus* 9, 28 (1957).
36. T. A. Rafter and G. J. Fergusson, Atom Bomb Effect—Recent Increase of Carbon-14 Content of the Atmosphere and Biosphere, *Science* 126, 557 (1957).
37. T. A. Rafter, *New Zealand J. Sci. Technol.* B37, 20 (1955); 18, 871 (1957).
38. M. Williams, private communication.
39. N. G. Stewart, R. G. D. Osmond, R. N. Crooks, E. M. R. Fisher, The World-wide Deposition of Long-Lived Fission Products from Nuclear Test Explosions, AERE HP/R 2354, (1957).
40. Geochemistry, Rankama and Sahama, University of Chicago Press (1950).
41. L. Machta, Indianapolis Meeting, AAAS, December 1957 (In press).
42. H. de Vries, Atom Bomb Effect. The Natural Activity of Radiocarbon in Plants, Shells, and Snails in the Past Four Years, *Science* (In press).
43. K. O. Munnich, private communication.
44. W. F. Libby, Radioactive Fallout and Radioactive Strontium, *Science* 123, 657 (1956).
45. W. F. Libby, Radiocarbon Dating, University of Chicago Press (1955), 2nd ed.
46. S. Kaufman and W. F. Libby, Natural Distribution of Tritium, *Phys. Rev.* 93, 1337 (1954).
47. F. Begemann and W. F. Libby, Continental Water Balance, Ground Water Inventory and Storage Times, Surface Ocean Mixing Rates and World-wide Water Circulation Patterns from Cosmic-ray and Bomb Tritium, *Geochim. et Cosmochim. Acta*, 12, 277-96 (1957).

STATEMENT BY DR. W. F. LIBBY ON CARBON 14 FROM BOMB TESTS

Bomb tests to date have produced enough carbon 14 so that when it has come to mixing equilibrium it will have increased the amount naturally present in all living matter by one-third of 1 per cent.

The normal radiation dose from carbon 14 may be compared with the increase in the dose from cosmic rays as the elevation increases. In these terms the normal carbon 14 dose (1.5 mr/year) is equal to about a 100-foot increase in elevation. Therefore, the extra radiation dose from this product of nuclear tests is equivalent to an increase in altitude of a few inches.

In the years before equilibrium with the deep ocean is reached—about 500 years—the level will temporarily rest at about a 3-per cent increase or the equivalent of a 3-foot altitude increase. This is after the first period of perhaps 10 or 20 years before dilution in the top layer of the ocean and with living and dead organic matter occurs, when the increase will be about 20 per cent, or about 20 feet equivalent altitude increase. Because the lifetime of radiocarbon is very long—8,000 years on the average—the equilibrium situation is the more significant.

STATEMENT ON RADIOACTIVE FALLOUT*

1 THE PROBLEM

The testing of nuclear weapons has injected into the atmosphere large amounts of radioactive materials in the form of dust of different particle sizes. These particles descend to the surface of the earth at different rates and constitute what is known as (radioactive) "fallout." Measurements of samples collected in different localities indicate that this radioactive material is widely distributed over the surface of the earth but with notable differences in surface concentrations. The world-wide fallout is due almost entirely to the explosion of megaton weapons which deliver fine radioactive dust into the stratosphere from which it descends slowly over a period of many years. Thus, in this case, fallout continues for a long time after the weapon has been exploded. Because of this long retention time, only radioactive substances of long half life, such as Sr^{90} and Cs^{137} , need be considered in connection with the problem of world-wide fallout in peacetime.

Ionizing radiation, in sufficient amounts, is known to produce deleterious effects in living organisms including man. Radioactive fallout on the surface of the earth can deliver radiation to animals and man in two ways: (1) by the external route, in which case the penetrating gamma radiation is of chief importance; and (2) by the internal route when the material is taken into the body with food, water, and air, in which case the radiation of low penetrating power can also reach the internal organs and, in fact, is of chief concern. Therefore, the problem is to estimate what harm may possibly result to man from the general increase in background radiation and from radioactive substances introduced into the body. This requires quantitative data on the accumulation of radioactive material on the ground and in the body.

Through many projects sponsored by the Atomic Energy Commission and from other sources, a great deal of information is available as to existing levels and the rates at which they are increasing. Assumptions have been made by different authorities to permit extrapolation to future levels on the basis that weapons testing will continue at the average rate of the past five years. Numerical values are constantly being revised as more information accumulates. The figures given below have been chosen by this Committee as typical ones but may not be the latest ones. It will be seen later that the general conclusions would not be altered by doubling or halving the numerical values used.

2 INCREASE IN GAMMA RAY BACKGROUND ATTRIBUTABLE TO FALLOUT

Radioactive fallout began in 1945 when the first atomic bombs were exploded in New Mexico and Japan. Subsequent tests of "conventional" atomic bombs in the Pacific and Nevada also produced fallout. However, in all these cases it was small in amount and more or less localized in extent. Fallout became a problem of world-wide interest after the firing of the first hydrogen

* Submitted to the U. S. Atomic Energy Commission by the Advisory Committee on Biology and Medicine: John C. Bugher, Charles H. Burnett, Simeon T. Cantril, H. Bentley Glass, Shields Warren, and G. Failla, Chairman.

bomb. The report of the Committee on the Biological Effects of Atomic Radiation, of the National Academy of Sciences (hereafter called the NAS report) states that "U. S. residents have, on the average, been receiving from fallout over the past five years a dose which, if weapons testing were continued at the same rate, is estimated to produce a total 30-year dose of about one tenth of a roentgen: and since the accuracy involved is probably not better than a factor of five, one could better say that the 30-year dose from weapons testing, if maintained at the past level, would probably be larger than 0.02 r and smaller than 0.5 r." The average world-wide 30-year dose is estimated to be considerably lower.

3 ACCUMULATION OF Sr⁹⁰

Strontium-90 fallout has been determined in a great variety of samples collected from different parts of the world. The item of chief interest in the present discussion is the concentration in human bones, especially those of children. However, the more extensive data on soil and milk show the trends with respect to time and are useful in the estimation of future concentrations in human bones.

3.1 Soil

The Sr⁹⁰ content of soil has been increasing considerably since 1954. Neglecting minor fluctuations, largely attributable to the periodicity of weapons tests, the increase in this period has been roughly proportional to time. At the end of 1956 the average surface concentration in the United States amounted to approximately 25 mc of Sr⁹⁰ per square mile. Merrill Eisenbud estimates that the average for the North Temperate Zone is 9.4 mc/sq mi and that for the South Temperate Zone 2.6 mc/sq mile.

3.2 Milk

The concentration of Sr⁹⁰ in milk has increased steadily with time and reached 5.6 μmc per gram of Ca in New York State milk in November 1956. It dropped to 3 μmc per gram Ca in April 1957, but the decrease may be due in part to seasonal variations (e.g., indoor feeding of cows during the winter).

3.3 Human Bones

The Sr⁹⁰ concentration in human bones is higher in children than in adults, as would be expected. Until whole skeletons, or sufficient representative samples thereof have been analyzed, quantitative figures must be regarded as rough approximations. In the meantime it seems reasonable to assume that, at least in the United States, the steady state concentration in bone per gram of calcium will be about one half of that in milk. (The values for milk are quite reliable because large samples can be used in making the measurements). Accordingly, in very young children it should be approximately one half of that in milk averaged over their lifetime (including fetal life). The concentration in milk ranged from 1-2 μmc of Sr⁹⁰ per gram of Ca.

It seems unrealistic to assume that tests of weapons of the present type will continue for generations. For the present purpose we shall use estimates of the predicted concentration of Sr⁹⁰ in the average human skeleton in the United States in equilibrium with fallout, under the following conditions: (1) if tests were stopped now, (2) if tests were to continue for 30 years at an annual rate equal to the average of the past 5 years, (3) if tests were to continue at this rate for many generations.

If weapons tests by all nations were stopped now, the concentration of Sr⁹⁰ in the skeletons of children in equilibrium with the concentration in milk, would gradually rise to an average value of 4 μmc per gram of Ca in the 1970's and would decrease slowly thereafter. This is based largely on estimates made by Merrill Eisenbud with Wright Langham.

If weapons tests of all nations were to continue for 30 years at an annual rate equal to the average of the past 5 years, (about 10 megaton equivalent of fission yield per year) the equilibrium concentration of Sr⁹⁰ in bone would reach an average value of about 15 μmc per gram of Ca in 100 years (as estimated by Langham) and would remain substantially at this level so long as testing continued at the same rate.

It should be noted that long range estimates of this kind are only intelligent guesses at best. For one thing, there is practically no information as to how Sr^{90} will be distributed in the soil after a long period of time, which, obviously, will influence its incorporation in plants. However, it seems fair to say that most of the envisaged factors that cannot be evaluated today, will probably make the actual concentration of Sr^{90} in human bones lower than the estimated values, rather than higher. For the purpose of evaluating possible injury to the population of the United States, we shall assume that the average concentration of Sr^{90} in bone in equilibrium with fallout will eventually reach 20 $\mu\mu\text{c}$ per gram of Ca, if tests continue at the present rate for many years. Since the average surface concentration of world-wide fallout is considerably lower outside the United States, the value applicable to the world's population is considerably lower than this.

The present maximum permissible concentration of Sr^{90} in bone for a large population is 100 $\mu\mu\text{c}$ per gram of Ca, according to the National Committee on Radiation Protection and the International Commission on Radiological Protection. The NAS Committee recommends the same concentration, but 50 $\mu\mu\text{c}$ of Sr^{90} per gram of Ca is also mentioned. Therefore, the estimated (biological and radioactive) equilibrium concentration of Sr^{90} from fallout in human bones in the United States, is 20 or 40 per cent of the MPC for large populations, recommended by authoritative bodies.

It should be noted that all figures given above are averages. Through a combination of unusual circumstances it is possible that fairly large numbers of people in some localities may accumulate Sr^{90} in their bones to a value five or ten times greater than the average for the United States or the world, as the case may be. This would bring the bone concentration of Sr^{90} above the permissible limit for large populations, but still below the limit for occupational exposure.

4 ESTIMATE OF POSSIBLE DAMAGE

4.1 General Considerations

The biological effects with which we are concerned in the peacetime fallout problem are those that might possibly result from long continued low level exposure to radiation (externally or internally). Our knowledge of such effects has been derived largely from animal experiments. Since the effects occur also spontaneously, it is always a matter of determining whether there is a real increase in the number of animals showing the effect in question caused by exposure to radiation. In order to obtain a statistically significant difference at very low levels of exposure, thousands of animals would have to be used. In practice it has been found expedient to use instead a high level of exposure to obtain statistically valid results using small numbers of animals. The question then arises as to how to estimate the effects of exposure at a much lower radiation level than was used in the experiments.

In the case of gene mutations it has been established, or at least it is believed by practically all geneticists, that the number of induced mutations is proportional to the dose received by the gonads up to the time of reproduction, no matter how low the dose is and no matter how it has been distributed with respect to time. On this basis it is then a simple matter to calculate the number of mutations that would be produced by a dose of radiation, however small, once the number for a large dose is known. To apply the results of animal experiments to man, various assumptions must be made, but there is good agreement among geneticists at least as to the order of magnitude of the effect.

In the case of somatic effects; that is, effects manifested in the exposed individual himself rather than in his descendants, the extrapolations to very low radiation levels and from animals to man are carried out in a similar manner. Here, however, the situation is more complex and the estimates are less reliable. The most important reason for the unreliability is that the mechanisms by which these effects are produced are not known. The extrapolation may be made by assuming direct proportionality between dose and number of individuals affected (as in the genetic case). This assumption implicitly denies the possibility that if the radiation level is low enough, a given somatic effect may not be produced at all, a conclusion that at the present time can neither be denied nor affirmed. It may be concluded, therefore, that proportional ex-

trapolation to very low radiation levels establishes the maximum value that may reasonably be expected, but it does not preclude the possibility that there may be no effect at all insofar as somatic effects are concerned.

4.2 Genetic Damage

Genetic damage from Sr^{90} is generally accepted as negligible because this element does not concentrate in the reproductive organs. There may be, however, some minor effect from its presence in the circulating blood or even from incorporation into the chromosomes themselves. Until more is known about such possibilities, calculations about genetic damage must continue to be based on the increase of background radiation due to long-lived gamma-ray-emitting isotopes in the fallout. It is estimated in the NAS report that in the United States the accumulated 30 year dose will be about 0.1 r, if weapons testing continues at the average rate of the previous five years. If the dose corresponding to the spontaneous mutation rate (doubling dose) in man is 50 r in 30 years (30 to 80 r is mentioned as the probable range in the NAS report), this means that the mutation rate will be increased by 0.2 per cent. Even if the doubling dose were as little as 10 r, which is probably the reasonable minimum, the increase would only amount to 1.0 per cent.

In the NAS report it is stated that 2 per cent of the total live births in the United States have tangible defects of genetic origin that appear prior to sexual maturity. According to genetic principles, it may be expected that the number of such defective individuals will ultimately be increased by 0.2 to 1.0 per cent of the present frequency by the predicated increase in background radiation resulting from gamma ray fallout. There are approximately 4,000,000 children born alive per year in the United States. The ultimate increase in genetically defective children will therefore be 0.2 to 1.0 per cent of 4,000,000 (160 to 800 per year as compared to 80,000 per year resulting from the spontaneous mutation rate). One may get larger *absolute* numbers by extending the calculation to the world's population of 2.7 billion. Assuming the same birth rate and the same estimated gonad dose of 0.1 r in 30 years as for the United States, the ultimate world-wide increase of defective children is 2500 to 13,000 per year. It should be noted that this is the ultimate increase; that is, the increase that would occur if the additional 0.1 r in 30 years persisted for a great many generations. In the first generation, the increase might amount to 10 per cent of the ultimate value. If the radiation from fallout were not to continue after the first generation, the *manifestation* of mutations would continue to increase for some generations and then would gradually return to the initial level. It should be noted also that the world-wide average increase in background radiation ascribable to fallout, is considerably lower than in the United States. Therefore, the above world-wide estimates are definitely too high, by a considerable factor.

The NAS report also stresses the conclusion that in any evaluation of genetic damage the total damage must include the effects of many mutations that do not produce tangible defects, at least when inherited from only one parent. The total damage, in fact, is more nearly equal to the frequency of mutations induced. The NAS report gives the estimates of six geneticists on the Committee that the induced mutation rate is probably about 0.5 per cent per roentgen per individual. If this figure is used as the basis of calculation, the total number of detrimental mutations induced by a gamma ray fallout dose of 0.1 r would be 2000 in the United States and 32,000 for the entire world, in contrast to a spontaneous frequency 100 to 800 times higher.

4.3 Leukemia

It is well known from animal experiments and from observations on humans that exposure to radiation in sufficient amounts induces leukemia in susceptible individuals. That some sort of susceptibility of unknown nature (perhaps genetic) is involved in the process, is evident from the study by W. M. Court Brown and R. Doll (Medical Research Council report) of the incidence of leukemia in ankylosing spondylitis patients treated with x-rays. Of the patients treated with maximum bone marrow doses of 2750 r or more, 0.176 per cent developed leukemia.

Neither the above mentioned study nor any other made so far provides the necessary information to decide whether there is a threshold dose that must be exceeded before leukemia is induced in man, but some animal experiments indicate the existence of a threshold. Also, the absence of a threshold is considered doubtful by most authorities in the field of hematology.

In estimating the effect of fallout radiation on the incidence of leukemia, it is generally assumed that there is no threshold and that the increase is proportional to the dose, even at very low levels of exposure. Based on this assumption and on the scanty available data, it may be calculated that exposure at the rate of 0.1 r in 30 years (the estimated gamma ray fallout dose rate) would increase the annual leukemia incidence in the population of the United States by 36 cases.

It has been suggested that Sr^{90} in the bone irradiates bone marrow in close proximity to bone and that this might induce leukemia. There is at present no evidence that leukemia can be produced in this way but the possibility cannot be excluded. It may be estimated that when the equilibrium concentration of Sr^{90} in bone ($20 \mu\mu\text{c}$ per gram of Ca, stated in Section 3) is reached, the dose rate to adjacent bone marrow will be about 0.03 rad per year. On the assumptions made over (and the inference that only leukemia of bone marrow origin could possibly be produced in this way), it may be estimated that at worst leukemia deaths in the population of the United States would be increased by about 160 per year, some years after the above mentioned equilibrium concentration of Sr^{90} had been reached. According to these calculations, the total possible increase in the leukemia deaths in the United States attributable to external and internal radiation from the estimated equilibrium amount of fallout, would be 196 per year. This amounts to 1.7 per cent of the present annual leukemia deaths (11,400).

It should be noted that any analysis or interpretation of the effect of fallout on the incidence of leukemia must take into account the fact that the *reported* death rates from leukemia in this country rose sharply between 1930 and 1954, as contrasted to a much more gradual increase between 1910 and 1930. Whether this increase represents an absolute increased incidence is less clear, for during these years there have been great changes in the span of coverage of reporting, in listings of cause of death, and in diagnostic criteria. Furthermore, analyses of 1954 figures demonstrate a striking age distribution with a peak during the first five years of life, a leveling off until the fifth decade, followed by a precipitous increase into the eighth decade. It should also be borne in mind that many drugs and industrial chemicals, by injuring hematopoietic organs, could be capable of inducing leukemia.

4.4 Bone Tumors

The induction of bone tumors in humans by ingested radium has been established clearly. Radiographic studies of the bones of living persons, apparently in good health, with long term radium body burdens of the order of $1 \mu\text{c}$, show small regions of damaged bone in different parts of the skeleton. Presumably these nonmalignant bone lesions are the result of local concentrations of radium. It is surmised that when bone sarcoma develops it originates in one of these regions. This is in accord with the well-known fact that cancer of the skin in grossly overexposed radiologists develops in localized areas showing persistent damage. It seems that the existence of a damaged region of tissue is a usual prerequisite for the development of cancer. In the case of radiation-induced cancer of the skin in radiologists, it is known that to produce the preliminary permanently damaged skin areas large doses of radiation are required (certainly more than 1000 r). Because of the high energy and the short range of the alpha rays of radium and its disintegration products, small local concentrations of radium are sufficient to deliver very large doses to the surrounding tissue in the course of the long latent period before bone sarcoma develops (15 or more years). It is well known that in general the smaller the radium body burden the longer it takes for cancer to develop. Among the radium dial painters, those who swallowed large amounts of material died within a few years of anemia, hemorrhages, and infections, rather than cancer.

A radium body burden of $1 \mu\text{c}$ produces a bone dose rate of about 40 rads per year (depending somewhat on the proportion of radon decaying *in situ* if it is uniformly distributed throughout the skeleton). If, as is likely, there are local concentrations of radium, the dose rate in these regions can be much higher. The smallest body burdens of *pure* radium that is known to have caused bone sarcoma in 24 years, is $3.6 \mu\text{c}$ at the time the tumor developed. Since a considerable fraction of the initial body burden was eliminated in this time, the bone dose in this case, for a uniform distribution, was nearly 6000 rads.

In x-ray therapy it is often necessary to irradiate bone in order to deliver the desired dose to a deep-seated lesion. Occasionally tumors have appeared in such irradiated bones

after a long latent period. The bone doses have always been large, the minimum being 1500 r in one of the reported cases.

The fallout equilibrium concentration of Sr^{90} in human bones of $20 \mu\mu\text{c}$ per gram of Ca, when it is attained, will deliver 0.056 rad per year, on the basis of a uniform skeletal distribution. The equilibrium concentration will obtain in individuals who have been exposed to fallout throughout life. Therefore, the Sr^{90} has been assimilated gradually and, since chemically strontium is very similar to calcium, a uniform distribution throughout the skeleton may well be expected. Certainly it should be more uniform than in the case of the radium dial painters who started ingesting the material in adult life. Furthermore, a spotty distribution of the Sr^{90} itself would produce a more uniform dose distribution in bone than in the case of radium, because of the much greater ranges of the beta rays of $\text{Sr}^{90} + \text{Y}^{90}$ as compared to the ranges of the alpha rays of radium. Accordingly, much higher dose rates than 0.056 rad per year, due to local Sr^{90} concentrations, are very unlikely. It is difficult to see, therefore, how local doses of the magnitude required to produce bone damage, and subsequently bone sarcoma, can possibly be reached in a lifetime. In 70 years the accumulated uniform distribution dose would be 3.9 rads, without allowing for radioactive decay of the more or less "fixed" Sr^{90} initially incorporated in the skeleton, which would make it even lower. Any reasonable allowance for non-uniform distribution cannot make the dose large.

If the mechanism for the induction of bone sarcoma is as outlined above, it is evident that proportional extrapolation to very low dose rates is hardly justified. Therefore, a dose rate in bone of 0.056 rad per year, which is about one half of the natural background level, may well be expected to produce no bone sarcomas at all. On any plausible basis, even the absolute number for the population of the United States cannot be large, since the annual deaths from bone sarcoma are approximately 2000.

4.5 Life Shortening

A statistical shortening of life has been obtained experimentally by exposing animals continuously or intermittently throughout life at daily rates in excess of 0.5 r. In some experiments exposure at the rate of 0.1 r per day seemed to prolong the average life. Since the number of animals used in these experiments has been too small to produce statistically significant results at this radiation level, no definite conclusions can be drawn from low level exposure experiments. Estimates of the life shortening in man quoted in the literature, ranging from 5 to 20 days per roentgen, have been derived from theoretical relationships between dose and life shortening based on animal experiments in which relatively large doses or dose rates were used. These estimates give a greater appearance of accuracy than is warranted by the basic data.

A recent survey conducted by Shields Warren shows that the average age at death for radiologists who died between 1930 and 1954 was 60.5 years as compared to 65.7 years for other physicians having no known contact with radiation. The doses received by these radiologists in the exercise of their profession are estimated to vary from rather low values to about 1000 r. Dublin and Spiegelman, on the basis of a shorter period of study (1933 to 1942), found no life shortening for radiologists. Hardin B. Jones, in a study of a group of radiologists and on the basis of a reanalysis of certain of Warren's data, finds that they have the same death rate risk as the general population at ages under 60, but over 60 the death rate is about twice as high as expected.

It should be noted that the higher incidence of leukemia among radiologists cannot lower appreciably the average age at death, because the disease is very rare, even among radiologists. The question is whether the not inconsiderable doses of radiation formerly accumulated by radiologists over a long period of time may have caused an acceleration of the aging process. A categorical answer to this question cannot be given at this time, but it may be assumed that the higher levels of radiation to which some of these radiologists were exposed may have caused an appreciable life shortening in a statistical sense. The estimated accumulated dose from fallout gamma rays (0.1 r in 30 years) is so small in comparison to the occupational exposure of radiologists in the past fifty years, that this effect if it exists at all at very low dose rates, can only be extremely small, a few days at worst.

5 APPRAISAL OF THE ACCEPTABILITY OF POSSIBLE DAMAGE

If extrapolation to very low exposure levels is justified, it may be expected that some damage, however slight, will be produced by radioactive fallout, in the present and future generations. Estimates of the number of individuals in the world's population who may show some damage in the course of time (many generations in the case of genetic damage) are large in absolute terms. Whether they are considered to be small in comparison to the unavoidable damage caused by spontaneous mutations and the presently accepted hazards of life, depends on the ethical and emotional makeup of the individual and, therefore, there can be honest differences of opinion. It is a fact, however, that we accept death and maiming through preventable accidents. (Most automobile accidents could be prevented by reducing the speed limit to 10 miles per hour). We discount the harm by considering the advantages. Also, in the case of most accidents the individual at least believes he can exercise some control. The fallout hazard is essentially beyond the control of the individual and involves, also, his descendants. This has a strong emotional impact.

Ionizing radiation has played an important part in many of the scientific and technological advances of this century. It is also an unavoidable by-product of the "atomic age." A certain amount of exposure, even under the most rigid controls, is inevitable. Thus, diagnosis of disease by means of x-rays necessarily involves irradiation of the body region under examination, even when the most stringent protective measures are employed. The NAS Committee on Genetic Effects of Atomic Radiation, recognizing the benefits as well as the harm that might result from the ever increasing production and use of ionizing radiation in our civilization, has recommended "that the general public of the United States be protected, by whatsoever controls may prove necessary, from receiving a total reproductive lifetime dose (conception to age 30) of more than 10 roentgens of man-made radiation to the reproductive cells." The same Committee emphasizes that this is a *reasonable* but not a *harmless* average dose for the whole population, insofar as genetic effects are concerned. This means, in effect, that if this average 30-year dose is not exceeded, the presently predictable genetic damage to the population is expected to be tolerable.

The same Committee estimated that a dose of 10 r to the population of the United States would give rise to some 50,000 new instances of tangible inherited defects in the first generation and about 500,000 per generation ultimately, assuming an indefinite continuation of the 10 r increased rate and also assuming a stationary population. The total number of mutants that would be induced by this radiation dose to the population of the United States and passed on to the next total generation, was estimated to be roughly 5,000,000 by six geneticists on the NAS Committee. These increases in the number of children with tangible inherited defects and the total number of mutants in the United States, therefore, are considered tolerable by present genetic standards. By the same token, the genetic damage that may be expected from the estimated gamma ray fallout dose of 0.1 r in 30 years, which is 100 times less, must be considered negligible.

The significance of possible somatic injury from fallout may be appraised similarly by reference to the "genetic dose" of 10 r in 30 years. Since fallout gamma rays reach the body essentially from all directions, the dose to the gonads is considerably less than that to the surface of the body. It may be assumed therefore, that in a fallout field that would give a gonad dose of 10 r of penetrating gamma radiation in 30 years, this is also the approximate dose in rads received by internal organs such as the blood forming organs and the skeleton. Consequently, the genetically acceptable dose corresponds to a dose rate in these organs of 0.33 rad per year. The estimated bone marrow dose rate from a Sr^{90} concentration in bone of 20 μc per gram of Ca is 0.03 rad per year and that in bone is 0.056 rad per year. Hence the possible increase in the leukemia death rate attributable to Sr^{90} in the skeleton would be 9% of that resulting from the genetically acceptable dose rate. The corresponding figure for the possible increase in the death rate from bone sarcoma is 17%. Hence, by the standards used by the Genetics Committee in arriving at the average population gonad dose of 10 r in 30 years, the possible increase in death rate from leukemia or bone sarcoma attributable to the estimated fallout, is well below the acceptable degree of damage. The same reasoning and conclusion apply to any other possible effect of fallout radiation of comparable dose rate in

any organ, since the 10 r in 30 years was set for external radiation that penetrates the whole body. (The conclusion remains unchanged even when the medical x-ray dose to the population is subtracted from the 10 r dose in 30 years.)

It will be seen that this appraisal of the tolerability of possible genetic and somatic damage does not involve the estimation of the number of possibly injured individuals or the degree of damage. The appraisal is made on the basis of dose rates, which are more readily determinable. The usual assumption that the effect is proportional to the dose rate was made in calculating the 9 per cent and 17 per cent figures given above. However, this is not essential because, if the dose rate in the tissue of interest is considerably lower than 0.33 rad per year, the effect is bound to be considerably less than that attributable in 10 r in 30 years. Nevertheless, it was thought desirable to include in this review the numerical estimates given in the preceding sections.

6 GENERAL CONSIDERATIONS AND RECOMMENDATIONS

As previously stated, the setting of an upper limit of 10 r in 30 years for the genetic dose to the population of the United States involved an estimated balance between possible harm and possible benefit. Since it must be assumed that some harm will result from fallout radiation, the question naturally arises as to whether this is justified by the benefit, even if it be well within recommended limits. In this country a large fraction of the annual budget is for military expenditures, which in a democracy gives a measure of the citizens' concern about the safety of their country. It seems obvious, therefore, that if we wish to maintain a first class military organization for the safety of the country, we must at least keep abreast of new weapons developments. No such developments can be carried out successfully without tests. (Obviously, it would be impossible for the Air Force to develop better military planes without ever testing them in flight.) Therefore, in terms of national security, necessary tests of nuclear weapons are justified. There are, however, other considerations that must be weighed carefully by those responsible for our national policy.

Radioactive fallout from our tests spreads all over the world. Similarly, tests made by others affect us. Other countries may want to develop nuclear weapons later. In time, the situation may well become serious. Estimates of ultimate damage to the world's present and future population, expressed in absolute terms, are large and impress many people. Judging from discussions in the public press, it is not generally realized that the estimated damage is well within tolerable limits, applicable to radiation exposure of the whole population in its normal peacetime activities. The question arises in the minds of many thoughtful persons whether the number and power of bombs exploded in the tests are being kept at the minimum consistent with scientific and military requirements. In view of the adverse repercussions caused by the testing of nuclear weapons, the Committee recommends that tests be held to a minimum consistent with scientific and military requirements and that appropriate steps be taken to correct the present status of confusion on the part of the public.

October 1957.

BIOLOGICAL FACTORS IN THE RADIATION PROBLEM RELATING TO SOCIETY *

Charles L. Dunham, M. D.

Director, Division of Biology and Medicine, U. S. Atomic Energy Commission

1 INTRODUCTION

Controlled nuclear fission which ushered in the "Atomic Age," like all great scientific achievements, has raised more questions than it has answered. It not only raised a myriad of questions which physicists, social scientists, and the United Nations have been busily trying to answer ever since, but for those of us in the health sciences it posed a host of health problems urgently requiring solution.

By 1940 the hazards of ionizing radiation were already understood in a general way. The cause and effect relationship between exposure to x-rays or to the emanations of radium and skin cancer was clearly recognized by 1902, a bare seven years after the discovery of x-rays by Roentgen. It has been known since the mid-twenties that radiation of germ cells can result in gene mutation, and radiation exposure during embryonic life results in developmental abnormalities. Only a few years later, radiation-induced leukemia in mice was observed.

From 1929 to 1940 what is now named the National Committee on Radiation Protection and Measurement has been cooperating with the International Commission on Radiological Protection in developing recommendations concerning the maximum permissible exposure of the relatively few adult workers using x-ray machines, radium, and later other sources of ionizing radiation. The recommendations were based on scientific facts, obtained both experimentally and by observation of injury incurred by pioneers in radiology and radiological physics and by the workers in the luminous dial industry. Since then as more and more data on the effects of radiation accumulated, these recommendations have been revised. The Atomic Energy Commission, in all its operations, has endeavored to follow these recommendations.

Public concern, and concern by scientists other than radiobiologists, with the effects of ionizing radiation on human beings became widespread as a result of the unfortunate accidental exposure of the Rongelapese to fallout in the spring of 1954 from atomic weapons testing in the Pacific. In June 1956, as a result of the report of the National Academy of Sciences study on the Biologic effects of atomic radiation, this concern spread rapidly from the hazards associated with radioactive fallout to include the hazards inherent in the medical uses of x-rays and in the coming age of nuclear power production.

One of the great difficulties in discussing this problem at the present time is that of achieving objectivity. Inherent in the present discussions of the effects of radiation is the matter of whether or not the United States should attempt to build optimal capability in the delivery of atomic weapons in the event of war and even as a deterrent to war. The subject has become intimately involved in many people's emotions. During the 1956 Presidential election campaign it even became a political issue.

*Presented at the Symposium on "Social Aspects of Science" at the Meetings of the American Association for the Advancement of Science, Indianapolis, Indiana, Dec. 29, 1957.

Another difficulty is one of achieving a proper perspective in dealing with the manner in which the delayed effects which might be produced by radiation would appear. The fact that any delayed effects are by definition ones which do not become apparent at once is baffling to the majority of people, and the fact that they could be produced by something as intangible as radioactive atoms lends the subject a weirdness that is hard to dispel.

We have a situation quite the reverse to what has pertained in the past with respect to the great epidemic diseases. Small pox, cholera, and typhoid fever epidemics were very real and terrible events which decimated whole populations in devastating fashion. The problem was to seek the cause and eliminate it by sanitation or by immunizing the population to the specific causative organism. With radiation hazards to society as a whole it is otherwise. There are no formidable pressing measurable effects for which to seek a cause. We can with varying degrees of confidence predict effects from the present rate of radiation exposure to the population that can never be measured or clearly identified with the specific cause. Yet each projected effect is described in the form of some well-known tragic event, a deformed or weakened child, leukemia, bone cancer, or the vague but seemingly familiar "premature death."

The problem is to find some means of comparing the hazards inherent in fallout and in the medical and industrial uses of atomic energy with some more familiar or man-made hazard which is presently tolerated for one reason or another. There is a natural tendency to reject comparison with the hazards from such a familiar thing as fire. Fire exacts 10,000 lives a year in this country and at the present rate 300,000 per generation. It scars and maims many thousands more. There is the same tendency to reject comparison with the automobile—a very real symbol of modern civilization and the cause each year in the United States alone of some 40,000 deaths and a like number of maimed—at the present rate more than a million killed per generation. Similarly people reject comparison with the accidental deaths and injuries which are very substantial and a sine quo non for our defense effort. I am sure that you will agree with me that these figures are needlessly high, must and can be reduced, just as injuries from radiation must be kept to a minimum. I suspect one of the reasons for the complacency about our present accident rate is the commonplace nature of the incidents which lead to death and injury. They are recorded in our newspapers daily. A hazard more comparable to that of radiation, smog or air pollution, cannot be used for comparison simply because we have no comparable body of knowledge upon which to base an estimate of the possible deleterious effects on our citizens. For radiation and especially radiation from fallout constitute the only contemporary man-made general environmental hazard about which we have sufficient information to define it at all. Nevertheless, just because it can be defined, there is a greater obligation to keep the radiation hazards minimal.

I believe that nuclear energy is here to stay. Like fire, without which man would still be living in caves, it can be a boom to mankind. Like fire, if used carelessly, it will cause death and destruction to property. If used in war, fire can be devastating; more property was destroyed and more people were killed in the July 10, 1945, fire raid on Tokyo than at either Hiroshima or Nagasaki from atomic bombs. But with megaton nuclear weapons now a reality, whether clean or dirty, this would all pale by comparison in the event of a nuclear war.

The present rate of exposure from medical and dental x-rays (4 r in 30 years) is of about the same magnitude as the exposure from natural sources of radiation. While the present levels of radiation exposure from weapons testing fallout (0.13 r in 30 years) and future levels at any realistic rate of weapons testing, whether by one nation or by many, are even lower, they are a fraction of the natural radiation exposure. In fact, these levels are well below the levels of radiation which have been employed in experimental work in order to demonstrate detectable pathologic or genetic changes.

2 GENETIC EFFECTS

In the field of genetics there are two principal hazards with which we are concerned when we study the effects of ionizing radiation as a mutagenic agent. First, there is the possible risk to the human race as a whole. There is undoubtedly some amount of radiation which, if the entire race were subject to it, would result in a mutation rate which would lead eventually to degeneration of the species. On the other hand, the maximum tolerable mutation rate for humans, tolerable in the sense of survival of the race, is not known.

The other hazard is to some individuals, the personal tragedies associated with the birth and life of a defective child. The NAS Committee has estimated that in the normal course of events in the next 30 years 100,000,000 children will be born in this country and that there will be among them some 2,000,000 with tangible genetic defects. If 40 r is taken as the radiation dose per generation necessary to double the present "spontaneous" mutation rate, the 10 r dose per generation mentioned in the NAS report as tolerable but not harmless would add in the United States alone 50,000 tangible defects in the first generation and eventually after 20 or 30 generations about 500,000 per generation, i.e., about 16,000 per year. A dose of 0.13 r to the gonads per U. S. generation is estimated to be insured from the present rate of weapons testing. This is estimated to produce in the first generation an additional 650 persons with tangible genetic defects, and if this rate of exposure continued there would eventually after some 20 to 30 generations be 6,500 per generation. There would be in addition about 5,000 embryonic and neonatal deaths, stillbirths, and childhood deaths in the first generation with eventually about 80,000 per generation. There would also be a larger but unknown number of minor intangible defects. Were the dose received by the world as a whole the same (actually it is lower), you would have to multiply all the figures by about 20. In absolute numbers they are large. On the other hand, when one compares them with the 2,000,000 tangible genetic defects which are now occurring in each generation and millions of embryonic, neonatal deaths, stillbirths and childhood deaths from genetic causes, they are a small fractional increase. The effects of medical x-rays could be said to be adding eventually about 1/10th to the present U. S. total, while fallout at the present rate of testing would add an increment of 1/300th.

3 LIFE SPAN

To the best of our knowledge, except for high level radiation to vital organs, the life shortening effects of ionizing radiation are the result of total-body exposure or they may manifest themselves in succeeding generations as a result of genetic damage. There is considerable experimental data in small mammals on the effects of fairly large single event whole-body exposure, i.e., 100 to 200 r and more given either once or repeated. There is considerably less information at smaller dose increments. In general it can be said that with large increments, 100 r and more, there is a curtailment of life expectancy from the time of exposure by approximately 25% per LD/50. Thus a single dose of 200 r would be expected to reduce an individual's life expectancy from that point on by roughly 12.5%. With smaller increments, a few r to upwards of 100 r, the effect in experimental animals is less marked. One explanation for this is the possibility of a partially effective reparative process. The curtailment of life expectancy is in these circumstances a little less than 1% per 100 r. If this holds for human beings an average individual who had accumulated at the age of 40 years approximately 100 r in increments of several roentgens at a time and who would normally be expected to live another 30 years would lose 3 to 4 months of his life span.

There is no definitive information at low dose rates, i.e., 0.1 r per day or 0.3 r per week and less which is in the range of the permissible exposure levels as recommended by the International Commission on Radiological Protection. A few experiments have been done in mice and rats. In each instance the average life span of the irradiated group was slightly higher than that of the control. It appears, however, that the sparing effect is during middle life, and perhaps, chronic low level exposure has some sort of nonspecific effect by permitting survival of experimental animals in the presence of certain ectoparasites. The longer-lived animals in the irradiated group did not live any longer than the longer-lived animals in the control group. In any event, a dose rate of 0.1 r per 30 year period would reduce the average life span by less than a day. While the dose rate of 4 r per thirty year period from diagnostic x-rays might curtail the average life span by at most 2 or 3 weeks.

4 LEUKEMIA

The present leukemia rate in the United States is approximately 11,400 cases per year. It is an established fact in many experiments done on animals that large doses of radiation do induce leukemia. In some experiments, although the total number of cases was not increased,

the onset was greatly accelerated by the radiation exposure. For doses of less than 100 r in humans and in statistically significant numbers of experimental animals, there are no definitive data. The available experimental data from fairly extensive studies at higher levels of radiation suggest that, depending on the type of leukemia, the induction curve may be either sigmoidal or linear. It is not known whether or not there is a threshold for leukemia induction by radiation. While it has been generally accepted among students of leukemia that there is some accumulated dose of radiation, perhaps in the vicinity of 50 r below which leukemia is not induced, Dr. E. B. Lewis of California Institute of Technology and Dr. Hardin Hones of the University of California at Berkeley have proposed the hypothesis that leukemia induction from ionizing radiation is a linear function of dose regardless of dose rate and have suggested that for each mr average exposure per year to the entire population of the United States, there would eventually be an additional 10 cases of leukemia per year, i.e., about 40 cases per year from fallout. Using this same reasoning there would be roughly 1200 cases per year as a result of diagnostic medical x-rays.

It has also been postulated that bone-seeking radioactive nuclides such as radiostrontium might be leukemogenic. The present average body burden of Sr^{90} in children in the United States is slightly less than 1/100th the maximum permissible bone concentration for Sr^{90} for the population as a whole. This has been given as 0.1 μc for an adult, i.e., 100 $\mu\mu\text{c}$ per gram of Ca. 100 $\mu\mu\text{c}$ per gram of Ca would lead to an exposure to nearby bone marrow of about 0.14 rad per year, that is, about 10 rad in a lifetime or less than 5 rad in 30 years. If Lewis' hypothesis is correct, that leukemia induction is linear with dose to the bone marrow, and were all the bone marrow to receive this dose, which it does not, such a body burden for all people in the United States could mean an additional 5 to 10% increase in leukemia (500 to 1000) each year. There are considerable experimental data indicating that with large single doses leukemia does not result if a fair fraction of the hematopoietic system is shielded from total body radiation. With a certain type of mouse lymphoma, even shielding one extremity of the animal will vitiate the leukemogenic effect of a large single exposure to radiation.

It appears then that if leukemia in general or even one type of leukemia can be the result simply of a radiation-induced somatic mutation untempered by homeostatic factors, fallout at the present rate of weapons testing could, on the basis of certain assumptions as to the number of cases of leukemia due to background radiation, result in some 30 to 40 additional cases per year or about 1000 per generation. The same assumptions lead to a figure of 1200 cases per year as the result of medical x-rays (12,000 per generation). If small amounts of Sr^{90} relatively uniformly distributed in bone can indeed produce leukemia in the manner postulated by Lewis, fallout from continued weapons testing at the present rate could eventually lead to 35 to 250 additional cases per year (1000 to 7000 per generation). To complete the story, one must keep in mind that cocarcinogenic factors and additive factors may in certain susceptible individuals prepare the way for a small dose of radiation to trigger a case of leukemia.

5 BONE CANCER

The present incidence of bone sarcoma in this country is about 2000 cases annually. It is apparent from the observations of radiotherapists that a dose of something more than 1000 r given locally to the bone is required to induce cancer, and cancer induction by doses of less than 2000 r is a very rare occurrence. As to the induction of cancer by chronic irradiation from bone-seeking radionuclides, we have a considerable body of data in human beings. Briefly, it can be stated that no case has come to light of bone cancer in an individual exposed to "pure" radium salt in adult life who had left in him at the time of observation (usually 20 to 30 years after the material was ingested) less than 0.4 μg of radium plus an undetermined amount of mesothorium. The National Committee on Radiation Protection and the International Commission on Radiological Protection have taken a little less than 1/10th of this figure, 0.1 μc , as the permissible radium burden for adult workers. The corresponding figure for Sr^{90} is 1.0 μc . One-tenth of that or 100 $\mu\mu\text{c}$ of Sr^{90} per gram of Ca, the presently considered permissible body burden for the population as a whole, would give about 0.26 rad per year or 20 rad in 70 years, i.e., approximately three times the exposure to bone from naturally occurring radioactivity.

Experimental work in mice and dogs at such low body burden levels is incomplete, but at somewhat higher levels of Sr^{90} in mice the curve for bone tumor production is steeply sigmoidal in nature, in other words, very few if any bone sarcoma will result.

6 SUMMARY

1. I have attempted to review for you in an objective way the best information now available on the possible cost to society of the privilege of making use of atomic energy.

2. The estimate for the genetic cost in terms of gene mutations is based on a wealth of scientific data and while not absolutely proven the burden of proof should lie with those who question it.

3. The basis for the estimate of the upper limit for the leukemia cost is still in the realm of hypothesis though it must be taken account of in computing a possible maximum cost of nuclear energy.

4. Estimates of the cost in terms of shortening of the average life span but exclusive of genetic effects as they may affect the life span of future generations are based on good data from experiments in animals exposed to dose increments of several roentgens. Whether there is any effect on life span at very low dose rates is not known.

5. The cost estimates discussed, even including the estimate for the ultimate genetic cost which is at least an order of magnitude greater than the highest cost estimates for leukemia are well below our present day experience with accidental deaths which is admittedly higher than need be.

6. All of these estimates assume that there will be no further advances in the biological sciences with respect to the prevention and treatment of leukemia and cancer in general, and in our ability to counteract or protect against the mutagenic effect of ionizing radiations.

7 CONCLUSION

Atomic energy like the other great technological advances is bound to exact some price of the society which makes use of it whether in peaceful pursuits or in its national defense effort. Our present knowledge of the hazards of radiation though incomplete is greater than for any other general environmental hazard. It is for the radiobiologist to continue to define the cost in more and more precise terms while it is up to society to decide whether the price is acceptable, and if the answer is in the affirmative, it must make certain that the cost is kept to a minimum.

ENTRY OF RADIOACTIVE FALLOUT INTO THE BIOSPHERE AND MAN*

Wright Langham and E. C. Anderson

Los Alamos Scientific Laboratory of the University of California, Los Alamos, N. Mex.

Dr. Wright Langham and Dr. E. C. Anderson of the Los Alamos Scientific Laboratory, have prepared a comprehensive review paper discussing world-wide fallout. Because of its excellence as a summary, the Joint Committee on Atomic Energy requested permission to publish the paper last year in the printed hearings on "The Nature of Radioactive Fallout and Its Effects On Man" (p. 1348). The paper is scheduled to appear in Vol. 1, Number 2, 1958, of *Health Physics*, official journal of the Health Physics Society. The title will be, "Potential Hazard of Strontium-90 from Nevada Weapons Testing."

In the light of information appearing in the past year, Dr. Langham and Dr. Anderson updated their paper and presented it before the Swiss Academy of Medical Sciences. We have especially asked for permission to reprint the updated paper here, and wish to acknowledge the permission granted by the authors, the Health Physics Society, and the Swiss Academy. The present paper will appear in the *Bulletin of the Swiss Academy of Medical Sciences* 14, 1958, Basle, Benno Schwabe & Company, as part of the Symposium on the Noxious Effects of Low Level Radiation at Lausanne, Switzerland, March 27-28, 1958.

1 INTRODUCTION

Discussion of the potential hazard of world-wide radioactive fallout from nuclear weapons tests may begin with the consideration of three basic facts.

1. The world population is receiving small exposure to radioactive materials originating from nuclear weapons testing. Fission products from bomb detonations have been and are being deposited over the surface of the earth, increasing the external gamma radiation background and finding their way into the human body through inhalation, direct contamination of food and water, and by transmission along ecological cycles from soils-to-plants-to-animals and to man.

2. Enough radiation, either from an external source or from radioactive isotopes deposited in the body, will produce deleterious effects. These effects may result in an increase in genetic mutations, shortening of life expectancy, and increased incidence of leukemia and other malignant and nonmalignant changes.

3. Radiation exposure is not a new experience for the world population. All life has been exposed to radiation since the beginning. Radiation from cosmic rays, from radioactive min-

* Prepared for the Swiss Academy of Medical Sciences' Symposium on the Noxious Effects of Low Level Radiation, Lausanne, Switzerland, March 27-29, 1958.

erals in the earth's crust and from radium, K^{40} , C^{14} , and thorium deposited in the body constitute this so-called natural background. The amount of natural background radiation is such that persons living to an age of 70 years receive an average total dose of about 7 rem, while their skeletons (as a result of radium and other radioactive materials deposited in the bones) receive an average dose equivalent to about 10 to 12 rem. The natural background dose to some segments of the population may be at least three times the average because of variations in cosmic ray intensity and composition of the earth's crust with geographic location.

The net result of fallout is a small increase in the radiation background to which all life is exposed. The problem of the potential hazard of world-wide fallout then becomes one of trying to ascertain the magnitude and significance of this increase in background dose with regard to its potential risk to man's health and well-being.

Contamination from nuclear weapons testing may be divided on the basis of local and distant (world-wide) fallout.

Local fallout is of primary significance in the event of war in which weapons with a high fission component may be detonated at or below the surface to maximize surface contamination. In this case, fission products of short and intermediate half-life are of major concern since local fallout occurs within a few hours after detonation.

Distant (world-wide) fallout is of significance both with regard to continued weapons testing and in the event of nuclear war. Since months and even years are required for fission products to deposit over the earth's surface, only the long-lived radionuclides are important.

External exposure from environmental deposition of gamma-emitting fission products is of concern primarily because of the potential production of genetic changes. Internal exposure is of significance primarily with regard to the potential production of somatic effects in the tissues in which the various fission products deposit upon entering the body.

This report is restricted mostly to the potential internal hazard of distant (world-wide) fallout, with emphasis on Sr^{90} . Strontium-90 is believed to be the most important radionuclide because of its similarity to calcium (resulting in a high rate of uptake by plants and animals), long physical and biological half-life, and high relative fission yield. These factors lead to high incorporation in the biosphere and a long residence time in bone. General contamination will result in the bones of the population eventually reaching an equilibrium state with Sr^{90} in the biosphere.

2 PRODUCTION OF BIOLOGICALLY IMPORTANT RADIONUCLIDES FROM WEAPONS TESTS

A crude estimate of production of biologically important radionuclides from past nuclear weapons tests would be helpful in assessing the potential hazard of present biospheric contamination and in extrapolating to future levels in the event of continued testing or nuclear war.

Statements during the Subcommittee Hearings of the Joint Committee on Atomic Energy, Congress of the United States¹ assumed a constant nuclear weapons test rate of 10 megatons of fission yield per year, beginning in the spring of 1952. This leads to a total testing by all nations of about 55 megatons of fission yield by mid-1957. The total estimate may be reasonably realistic; however, the assumption of a constant test rate is highly questionable.²

One megaton of fission energy release results in the production of about 100,000 curies of Sr^{90} ,³ which suggests a total Sr^{90} production of 5.5 megacuries from weapons tests by all nations to mid-1957. From the fission yield curve (thermal neutron fission of U^{235}) and the appropriate decay constants, it is possible to make a crude estimate of the total production of other radionuclides of potential biological importance. Table 1 shows estimates of total production (in terms of megacuries of initial activity) and other pertinent data for the more important intermediate- and long-lived components of fission debris. The values for total yield are crude approximations only because it was necessary to use the fission yield curve for thermal neutron fission of U^{235} , and isotopic abundance varies with the fissionable material and the neutron energy. None of the values, however, are incorrect by more than a factor of about 2.

The total production of Pu^{239} was estimated from the report of Stewart, Crooks, and Fisher,⁴ who postulated from analysis of bomb debris that one Pu^{239} atom was formed per

Table 1—POTENTIALLY HAZARDOUS RADIONUCLIDES IN FALLOUT FROM NUCLEAR DETONATIONS

Radionuclide	Type of radiation	Fission* abundance, %	Radiol. half life	Total† production, megacuries	Abs. on ingestion, %	Body MPL, μc
Pu ²³⁹	α		24,000 yr	0.3	3×10^{-3}	0.037
Sr ⁹⁰	β	5.0	27.7 yr	5.5	30	1.0
Cs ¹³⁷	β, γ	6.2	26.6 yr	7.2	100	54
Pm ¹⁴⁷	β	2.6	2.64 yr	30	1×10^{-2}	60
Ce ¹⁴⁴	β, γ	5.3	285 day	200	1×10^{-2}	5
Zr ⁹⁵	β, γ	6.4	65 day	1100	1×10^{-2}	26
Y ⁹¹	β	5.9	58 day	1150	1×10^{-2}	5
Sr ⁸⁹	β	4.6	51 day	950	30	4
Nb ⁹⁵	β, γ	6.4	35 day	2000	1×10^{-2}	76
Ba ¹⁴⁰	β, γ	6.0	13 day	5000	5	4
I ¹³¹	β, γ	2.8	8 day	4000	100	0.7

*Slow neutron fission of U²³⁵; abundance in weapon debris is somewhat different.

† Total initial activity in megacuries produced by all weapons tests to mid-1957.

fission by neutron interaction with bomb components. Since 1 kiloton of fission yield is produced by 1.4×10^{23} fissions,³ each of which results in the production of a Pu²³⁹ atom, 55 megatons of fission would produce 0.2 megacuries of Pu²³⁹. Other isotopes of plutonium, when converted to equivalents of Pu²³⁹, bring the total production to about 0.3 megacurie equivalents. The production values given in Table 1 are not a measure of the relative biological importance of the various nuclides, but merely provide some general idea of the relative initial activities produced by all weapons tests through mid-1957. Development of sufficiently sensitive detectors should result eventually in detection of most of these radionuclides in foods and man. Strontium-90 (references 5 and 6), Cs¹³⁷ (reference 7), and I¹³¹ (reference 8) have been measured quantitatively in the human body, and the presence of Ce¹⁴⁴ in pooled urine samples has been reported.⁹ In addition, Ba¹⁴⁰ (reference 10) and Sr⁸⁹ (reference 11) have been observed in milk, and other radionuclides have been detected in air and other materials composing man's environment. The extent to which they pose a potential threat to man's health and well-being depend on their rate of production and on their individual physical and biological properties.

3 DISTRIBUTION OF FALLOUT FROM NUCLEAR DETONATIONS

3.1 Postulated Mechanisms of Distribution

Libby^{5,12} was first to propose a model explaining fallout and distribution of atomic debris from nuclear weapons detonations. His model is based on three kinds of fallout—local, tropospheric, and stratospheric.

Local fallout is deposited in the immediate environs of the explosion during the first few hours. This debris consists of the large particles from the fireball and includes partially or completely vaporized residues from the soil and structures which are swept into the cloud.

Tropospheric fallout consists of that material injected into the atmosphere below the tropopause which is not coarse enough to fall out locally. This debris is sufficiently fine that it travels great distances, circling the earth from west to east in the general latitude of the explosion, until removed from the atmosphere (with a half-time of 20 to 30 days) by rain, fog, contact with vegetation, and other meteorological and/or physical factors.

Stratospheric fallout is composed of fission products that are carried above the tropopause and can result only from large weapons (of the order of 1 megaton and greater). Libby^{13a,b} has postulated that atomic debris, once it is injected above the tropopause, is mixed rapidly throughout the stratosphere and falls back uniformly into the troposphere with a half-time of about 7 years. As it returns to the troposphere, it is deposited over the earth's surface in relation to meteorological conditions. He attributed the higher Sr⁹⁰ soil concentrations in the

United States to meteorological conditions and to local and tropospheric fallout as a result of the proximity of the Nevada Test Site. The generally higher concentrations in the north temperate latitudes were attributed to prevailing meteorological conditions and their effects on tropospheric fallout from tests in the USSR and at the United States Pacific Proving Grounds.

Machta¹⁴ proposed a model of stratospheric fallout which differs in some respects from Libby's. He postulated that stratospheric mixing is slow and that stratospheric distribution of fission products is still nonuniform. He feels that a major portion of the nuclear debris is still in the northern portions of the northern hemisphere, rather than uniformly spread over the entire globe or even uniformly dispersed in the northern hemisphere itself. He feels also that stratospheric movement of the fission products is largely by direct transport from west to east in the general latitude of the point of injection with very slow vertical mixing. Slow polewards circulation of stratospheric air from equatorial regions provides some mixing toward the poles. The higher concentration of fallout in the temperate latitudes is explained on the basis of air exchange between the stratosphere and troposphere through the break in the tropopause in the vicinity of the jet streams. A large part of the higher concentration of Sr⁹⁰ found in the northern part of the United States may result from preferential stratospheric leakage in the vicinity of 30°N to 40°N latitude instead of the proximity of the Nevada Test Site. Qualitatively, both models predict the same general distribution of fallout. Quantitatively, the Machta model predicts a greater degree of nonuniformity of fallout over the earth with higher deposition of fission products in the north and south temperate latitudes from nuclear debris still in the stratospheric reservoir. Figure 1 shows the essential features of the Machta model and the present general world-wide surface distribution pattern of Sr⁹⁰.

3.2 Average Maximum Surface Deposition Levels

(a) *Present Levels (1956-1957)*. A crude indication of latitudinal distribution of the integrated Sr⁹⁰ surface deposition levels as of June 1956, derived from soil data, is shown by the lower curve in Fig. 2. This curve is essentially the same as the one given by Machta¹⁴ except a few points have been added and the peak concentration in the north temperate latitudes is drawn slightly higher to allow some weighting for average Sr⁹⁰ levels in United States soils. These data suggest a level of about 13 mc/sq mile for the north temperate latitudes. No soil data are available yet for mid-1957. Fallout data from pot collections in New York and Pittsburgh, however, showed that cumulative Sr⁹⁰ fallout increased by about 50 per cent from June 1956 to June 1957.¹⁵ The upper curve in Fig. 2 represents estimated latitudinal fallout distribution in June 1957. Some of the increase in New York and Pittsburgh fallout could have been tropospheric contribution from Russian tests, which would result in over-prediction of the Sr⁹⁰ levels in other areas. This and other criticisms, however, seem minor compared to the uncertainty in the primary soil data.

Estimated deposition levels in June 1957 show a total Sr⁹⁰ fallout of about 19 mc/sq mile for the north temperate latitudes, 3 to 4 mc/sq mile for the equatorial regions, and about 5 to 6 mc/sq mile for the south temperate latitudes (Fig. 1). Data from pot collections in the New York area suggest total Sr⁹⁰ deposition levels of about 35 mc/sq mile in the northern United States in mid-1957. The rapid build-up of Sr⁹⁰ in the northern states in the spring of 1957 cannot be attributed to tropospheric fallout from Nevada tests, since Operation Plumbbob had not begun. It may be due to tropospheric fallout from spring test operations in the USSR and to preferential stratospheric fallout from past tests.

The total amount of Sr⁹⁰ deposited over the earth's surface (from both tropospheric and stratospheric fallout) as of mid-1957 can be estimated from the upper curve in Fig. 2 by replotting the data in terms of Sr⁹⁰ deposition/degree times the earth's area/degree. This calculation suggests a world total deposition of 1.64 megacuries, which gives a world average surface level of 8.2 mc/sq mile.

Libby's¹² estimates of Sr⁹⁰ surface deposition levels for the fall of 1956 were 22 mc/sq mile for the northern United States, 15 to 17 mc/sq mile for similar latitudes elsewhere,* and 3 to 4 mc/sq mile for the rest of the world. These values are in good agreement with those

* The north temperate fallout band was indirectly defined as the region between 60°N-10°N latitude. It is assumed that the surface deposition of 16 to 17 mc/sq mile applies to this area.



Fig. 1—Mechanism of distribution of world-wide fallout.

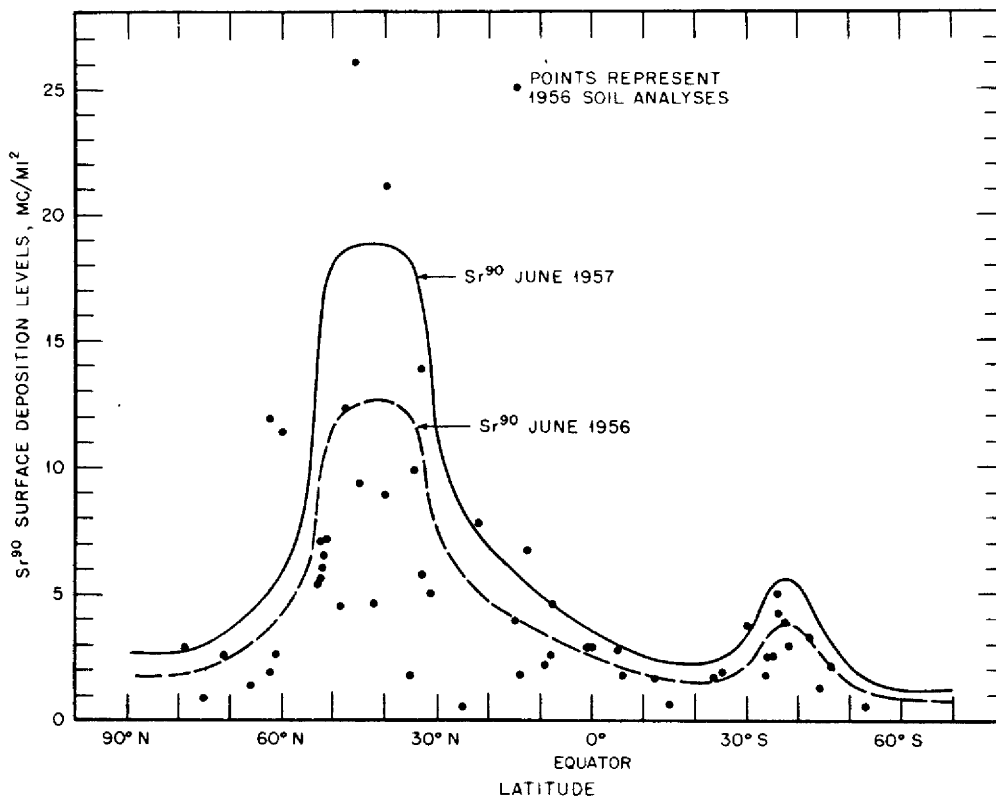

Fig. 2—Surface deposition levels of Sr^{90} from soil analyses.

estimated from the lower curve of Fig. 2. He also estimated the stratospheric reservoir at about 2.4 megacuries (24 megaton equivalents of fission yield). His predictions were based on 1955 soil analyses, his model of tropospheric and stratospheric fallout, and a general knowledge of the megatons of fission devices detonated during the spring and summer of 1956. Using his deposition values and the world Sr^{90} production up to that time, 24 megaton equivalents still in the stratosphere would be possible only provided local fallout from surface detonation of megaton weapons was about 25 per cent.

Values for the world total production (about 5.5 megacuries to mid-1957) and deposition of Sr^{90} may be used to estimate the present magnitude of the stratospheric reservoir. Fallout measurements from United States megaton detonations in the Pacific suggest that 50 ± 17 per cent of fission debris falls out locally. The rest is partitioned between tropospheric and stratospheric fallout. Since the fallout time of tropospheric debris is of the order of 20 to 30 days, the material not accounted for by local fallout plus total world-wide deposition must still be in the stratospheric reservoir. Such a material balance calculation estimates the stratospheric Sr^{90} content at 1.11 ± 0.93 megacurie, or the equivalent of 11.1 ± 9.3 megatons of fission yield. The average is about one-half the value estimated by Libby.¹²

High altitude air sample measurements suggest that considerable specific fractionation of fission debris is occurring. If, however, it is assumed that serious fractionation of Sr^{90} , Pu^{239} , and Cs^{137} does not occur,¹² it is possible to estimate the general distribution of these nuclides in relation to Sr^{90} . Since their radiological half-lives are long compared to the period of testing and the stratospheric storage time, their general distribution should be in direct ratio to their total production relative to that of Sr^{90} (Table 1). On this basis, average maximum surface deposition levels of Pu^{239} and Cs^{137} in the north temperate latitudes (by mid-1957) would be about 1.2 and 25 mc/sq mile, respectively.

Present world-wide distribution of Cs^{137} and Pu^{239} , estimated on the above basis, are compared with Sr^{90} in Table 2.

The estimated levels are general averages only and assume no fractionation and uniform distribution within the respective areas. Actually, this general picture is greatly over-

Table 2—COMPARISON OF WORLD-WIDE DISTRIBUTION OF
Sr⁹⁰, Cs¹³⁷, AND Pu²³⁹ FROM NUCLEAR DETONATIONS*

Region	Mid-1957		
	Sr ⁹⁰ , mc/sq mile	Cs ¹³⁷ , mc/sq mile	Pu ²³⁹ , mc/sq mile
Northern USA	35	46	2.1
North temperate latitudes	19	25	1.2
South temperate latitudes	5-6	7	0.3
Rest of world	3-4	5	0.2
World average	8	10	0.45
Total surface deposition	1.64 MC	2.1 MC	0.10 MC
Stratospheric reservoir	1.10 MC	1.4 MC	0.06 MC

* Assuming no fractionation.

simplified. Some fractionation is indicated by air sampling data and once fission products are suspended in the troposphere (either directly from the detonation or from stratospheric leakage, regardless of mechanism) meteorological conditions play a major role in their surface distribution. Libby has stressed the importance of rainfall, snow, fog, and mist.^{5,12} Within any major area fluctuations in levels of surface deposition may occur which correlate with local meteorological conditions. Machta¹⁴ has guessed that areas as large as milksheds may not have more than 2 to 3 times the average deposition for the latitude. He points out, however, that desert areas where there is practically no rainfall may have almost zero fallout.

(b) *Future Levels (Assuming No More Tests)*. Fallout of Sr⁹⁰ and other long-lived radionuclides from the stratospheric reservoir will continue even if weapons tests are stopped. Whether the integrated surface deposition levels continue to build up will depend on whether the rate of stratospheric fallout more than compensates for the rate of decay of material already on the ground.

From the surface deposition levels in Table 2 and the value of 1.1 ± 0.9 megacuries of Sr⁹⁰ for the stratospheric reservoir, estimation of future deposition levels, assuming no more weapons tests, is possible.

If $M(t)$ is the surface deposition level and $Q(t)$ is the stratospheric storage in millicuries per square mile at any time, the rate of change of the surface deposition level is:

$$\frac{dM(t)}{dt} = -\lambda M(t) + kQ(t)$$

where λ is the radioactive decay constant of Sr⁹⁰, and k is the stratospheric fallout rate constant (assumed to be first order). If $\lambda M(t) = kQ(t)$, dM/dt is zero. In this case, additional stratospheric fallout just compensates for radioactive decay, and $M(t)$ does not change. Such an equilibrium state is transitory, since $Q(t)$ is constantly decreasing (both by decay and by fallout). Loss by radioactive decay in $M(t)$, therefore, soon exceeds gain from $Q(t)$, and $M(t)$ falls. If λM_0 is greater than kQ_0 (where M_0 and Q_0 are the concentrations at $t = 0$, the time of cessation of tests), the latter situation already exists and the ground level begins to fall when testing stops. Only if λM_0 is less than kQ_0 will additional fallout from the stratosphere exceed the decay of the ground contamination and the surface deposition level continue to rise. If the mean times of decay and fallout are 40 and 10 years, respectively, $Q(t)$ must be at least $\frac{1}{4} M(t)$ for surface deposition to increase.

Future levels, in the event of no more testing, can be estimated if it is assumed that fallout in the future will have the same degree of nonuniformity as in the past. In this case, the effective stratospheric storage ($Q(t)_e$) for a given area is related to the average stratospheric storage ($Q(t)_{av}$) by the equation:

$$Q(t)_e = \frac{M(t)}{M(t)_{av}} Q(t)_{av}$$

where $M(t)$ is the observed ground concentration in the area in question, and $M(t)_{av}$ is the averaged world-wide ground concentration. On the basis of this assumption, the soil levels increase everywhere by the same ratio and reach a maximum about 1963, which is some 10 per cent higher than present levels.

Assuming uniform stratospheric fallout, some areas do not increase since the additional stratospheric fallout is insufficient to compensate for radioactive decay. The time of maximum ground concentration (where it does occur) varies also with location, being about 1966 in the south temperate latitudes and 1969 elsewhere.

Neither method of estimation is strictly correct. The assumption of uniform fallout may underestimate build-up in the northern latitudes, and the assumption of nonuniformity of future fallout according to the past may tend to overestimate build-up in those areas where some of the material deposited in the past came from tropospheric fallout. As stated by Machta,¹⁴ it is hoped that the truth lies somewhere in between. It must also be kept in mind that the stratospheric reservoir may well be 2.4 megacuries as estimated by Libby.¹²

Future Cs^{137} levels, assuming no fission product fractionation and no more tests, will be about 1.3 times higher than the corresponding Sr^{90} levels since their radiological half lives are essentially the same. Pu^{239} levels will continue to rise for several years because of its 24,000-year half life. In this case, λM_0 will be less than kQ_0 until the stratospheric reservoir is essentially depleted. However, surface deposition levels will not increase more than 0.6, which is the ratio of the present total surface deposition to the estimated stratospheric reservoir.

Table 3—PREDICTED AVERAGE MAXIMUM SURFACE DEPOSITION LEVELS OF Sr^{90} , Cs^{137} , AND Pu^{239} (ASSUMING NO MORE WEAPONS TESTS AFTER MID-1957)

Region	Sr^{90} , mc/sq mile*	Cs^{137} , mc/sq mile*	Pu^{239} , mc/sq mile†
Northern USA	39	51	3.3
North temperate latitudes	21	27	2.0
South temperate latitudes	6	8	0.5
Rest of world	4	5	0.3
World average	9	12	0.8

* Maximum will be reached in about 1965.

† Maximum will be reached essentially in about 30 years.

Predicted average maximum surface deposition levels of Sr^{90} , Cs^{137} , and Pu^{239} (assuming nonuniform fallout and cessation of tests) are given in Table 3. Surface deposition levels of other biologically significant isotopes, which all have short half lives compared to the stratospheric storage time and for which λM_0 is already greater than kQ_0 , will begin decreasing immediately when weapons tests are stopped.

(c) *Future Levels (With Continued Testing)*. If weapons tests continue at a constant rate (in terms of fission yield), the decay of radionuclides in the biosphere will eventually equal the rate of production, and continued testing will result in no further increase in deposition levels. At the present rate of testing (assumed to be 10 megatons of fission per year for the past 5 years), equilibrium Sr^{90} and Cs^{137} levels will be reached in about 100 years. Isotopes with shorter half lives will reach equilibrium sooner. Pu^{239} obviously will continue to increase essentially in proportion to its total production.

Campbell¹⁶ and Stewart et al.⁴ have estimated surface deposition levels of Sr^{90} at equilibrium with a uniform test rate, and their calculations suggest levels about 30 times the present values. Their equations are derived, however, from stratospheric fallout and apply to ground levels due to the stratospheric component only.

Libby¹⁷ estimated surface build-up on the basis of total levels on the ground at $t = 5$ years and predicted equilibrium levels 11 times the present values. His calculations have been checked by Neuman¹⁸ and others. Libby also assumed that about 30 per cent of the Sr^{90} (over

the long period required for equilibrium) would become unavailable to plants and the available equilibrium levels would be only about 8 times the present values.¹ Attempts are being made to obtain actual yearly fission product production rates to refine further predictions of surface levels under continued testing. Until then, an equilibrium build-up factor for Sr⁹⁰ and Cs¹³⁷ of about 10 with a continued average test rate of 10 megatons of fission yield per year seems reasonable. Table 4 shows future average maximum surface deposition levels of Sr⁹⁰, Cs¹³⁷, and Pu²³⁹ calculated, on the above basis, from the data in Table 2.

Table 4—AVERAGE MAXIMUM SURFACE DEPOSITION LEVELS OF Sr⁹⁰, Cs¹³⁷, AND Pu²³⁹ (ASSUMING A CONTINUING TEST RATE OF 10 MEGATONS OF FISSION YIELD PER YEAR)

Region	Sr ⁹⁰ , mc/sq mile*	Cs ¹³⁷ , mc/sq mile*	Pu ²³⁹ , mc/sq mile†
Northern USA	350	460	40
North temperate latitudes	190	250	24
South temperate latitudes	55	70	6
Rest of world	35	50	3
World average	80	100	11

* At equilibrium in about 100 years.

† In about 100 years, not at equilibrium.

Others have made similar estimates of Sr⁹⁰ surface deposition levels. Libby¹⁹ estimated equilibrium levels for the United States at 400 to 600 mc/sq mile. Neuman¹⁸ estimated a United States deposition level of about 400, and Machta¹⁴ 350 to 850 mc/sq mile.

4 INCORPORATION OF NUCLEAR DEBRIS INTO THE BIOSPHERE AND MAN

Radionuclides from fallout may enter the body through inspiration of the contaminated atmosphere and by ingestion of contaminated food and water.

Stewart et al.⁴ estimated the mean Sr⁹⁰ and Pu²³⁹ concentrations in air at ground level in England during 1952-1955 as 4×10^{-16} and 3×10^{-17} $\mu\text{c}/\text{cc}$, respectively.* Assuming the ratio of Cs¹³⁷/Sr⁹⁰ in air is the same as their ratio of total production, the mean Cs¹³⁷ concentration in air during the same period would be 5×10^{-16} $\mu\text{c}/\text{cc}$. The respective occupational maximum permissible air concentration of Sr⁹⁰, Pu²³⁹, and Cs¹³⁷ recommended by the International Commission on Radiological Protection²¹ are 2×10^{-10} , 2×10^{-12} , and 2×10^{-7} $\mu\text{c}/\text{cc}$. The estimated mean values are 5 to 8 orders of magnitude lower than the maximum permissible air concentrations recommended for the general population.

Since the tropospheric fallout time is 20 to 30 days, the mean air concentration values during 1952-1955 probably approximate equilibrium conditions with the past 5-year rate of biospheric contamination from stratospheric fallout.²⁰ In this case, continued weapons tests at the past rate should not increase the mean air concentrations greatly. As suggested by Stewart et al.⁴ and Bryant et al.,¹¹ inhalation of nuclear debris is not a major factor in the potential hazards of world-wide fallout.

Comparison of measured and estimated concentrations of the principal long-lived radionuclides in water with the maximum permissible concentrations recommended by the International Commission on Radiological Protection²¹ suggest also that ingestion of contaminated drinking water is relatively unimportant.¹¹

Ingestion of food contaminated through soil integration and plant uptake of long-lived radionuclides seems to pose the major potential hazard.

When nuclear debris is deposited on the earth's surface and incorporated in the soil, the individual nuclides are taken into plants through the root system according to their individual

* Their calculated value agrees reasonably well with the average measured value of 3×10^{-16} $\mu\text{c}/\text{cc}$ (for the same period at Washington, D. C.) reported by Martell.²⁰

soil-p
tamin
the ra
tained
clides
absorl
propo

A
since
conce

4.1 S

(a
bolical

ecolog
calciu

It
calciu

may be
all Sr⁹⁰

vidual
Menze

soil ty
tained

A
Alexan

from n
Th

diet m
calciu

States
about 8

basis c
DF₁) =

librium
5 per c

It
apply c

matica
depth o

dilutor
that it

ference

(b)
equilib

crimine
predict

As
1 mc of

If all of
gives tl

of avail
specific

modeli
concent

soil-plant relationships. That which settles directly on vegetation may remain as surface contamination or may enter the plant through foliate absorption. When plants are eaten by animals, the radioactivity incorporated in the plants or deposited on their surfaces is absorbed and retained by the animal according to the specific metabolic characteristics of the individual nuclides. When plant and animal products are eaten by man, the radioelements they contain are absorbed and incorporated into his tissues, again in accordance with their individual metabolic properties.

A few of the long-lived radionuclides in nuclear debris will be considered individually, since their accumulation in the soil and ecological transport to man appear to be the major concern.

4.1 Strontium-90

(a) *Ecological Incorporation and Discrimination.* Strontium-90 is chemically and metabolically similar to calcium. Therefore, it is incorporated into the biosphere along the same ecologic chain. It is taken into plants through the root system in relation to available soil calcium and absorbed and deposited in human bone in relation to the Sr^{90}/Ca ratio in the diet.

It is reasonable to assume that strontium may be discriminated against with respect to calcium in passing along the ecological chain. For example, the Sr^{90}/Ca ratio of human bones may be expected to be lower than that of soil. Attempts have been made to determine the over-all Sr^{90}/Ca discrimination ratio in going from soils to human bone by determining the individual discrimination factors (DF) that occur at the various steps along the ecological cycle. Menzel²² obtained a soil-to-plant discrimination factor (DF_1) of 0.7 for four widely different soil types using both radioactive and stable strontium. Larson²³ and Bowen and Dymond²⁴ obtained comparable values.

A discrimination factor (DF_2) of 0.13 in going from plants-to-milk has been reported by Alexander et al.²⁵ and Comar,²⁶ and the discrimination factors (DF_3) from plants-to-bone and from milk-to-bone (DF_4) have been estimated at 0.25.^{27,28}

The over-all discrimination ratio ($\text{OR}_{\text{bone-soil}}$) in going from soil-to-human bone via the diet may be estimated from the various discrimination factors and the fraction of dietary calcium derived from dairy products and from other sources. For example, for the United States population the amount of dietary calcium derived from dairy products is estimated at about 80 per cent. The remainder is derived from cereals, vegetables, meats, etc. On the basis of the above generalizations, $(\text{OR}_{\text{bone-soil}}) = (0.8 \times \text{DF}_1 \times \text{DF}_2 \times \text{DF}_3) + (0.2 \times \text{DF}_1 \times \text{DF}_4) = (0.8 \times 0.7 \times 0.13 \times 0.25) + (0.2 \times 0.7 \times 0.25) = 0.05$ and indicates that the average equilibrium concentration of Sr^{90} in bone calcium for the United States population will be about 5 per cent of the concentration in the available soil calcium (Fig. 3).

It should be emphasized that over-all discrimination ratios derived in the above manner apply only to passage along the ecological chain. The ecological discrimination ratio automatically assumes that calcium and strontium are uniformly mixed in soil to the average depth of the plant feeding zone. No allowance is made for direct foliar contamination, for dilution with a greater reservoir of available soil calcium through plowing, for the possibility that it may become less available with time through soil binding and leaching, or for differences in uptake by different plant species.

(b) *Sr^{90} Levels in Bones of the Population.* Present and future average maximum Sr^{90} equilibrium levels in bones of the population can be estimated from the soil-to-bone discrimination ratio, the ratio of milk to other sources of calcium in the diet, and the present and predicted average maximum surface deposition levels given in the previous sections.

Assuming an average of 20 g of available Ca per square foot of soil to a depth of 2.5 in., 1 mc of Sr^{90} per square mile is equivalent to 1.8 μc Sr^{90} per gram of available soil calcium. If all of the Sr^{90} is in available form, multiplication of the surface deposition levels by 1.8 gives the Sr^{90} activity per gram of available soil calcium. Multiplication of the specific activity of available soil calcium by the Sr^{90} discrimination ratio should give the average maximum specific activity of calcium laid down in the adult skeleton through exchange and bone remodeling during the period of environmental contamination and the average maximum Sr^{90} concentration in a skeleton at equilibrium with the integrated surface deposition levels.

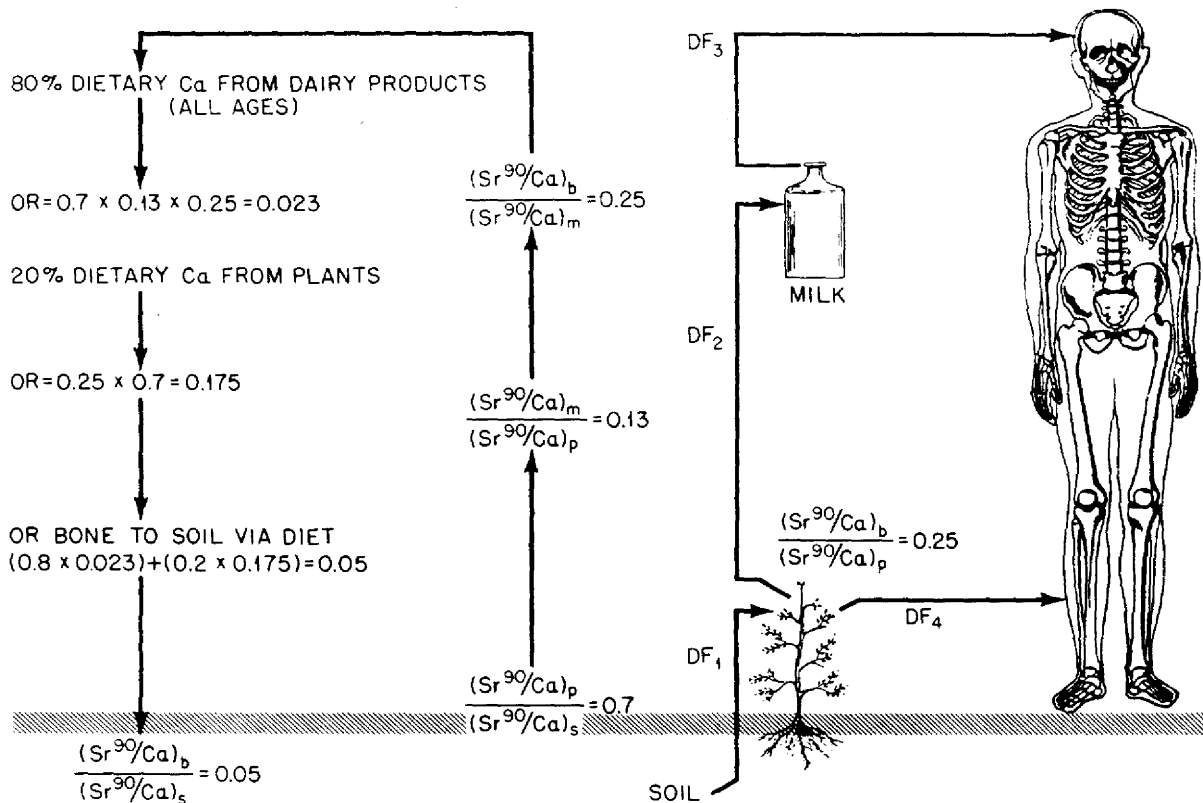

Fig. 3—Ecological discrimination against Sr⁹⁰ with respect to calcium (United States).

The fraction of dietary calcium derived from dairy products varies widely among the various populations. A general expression for the ecological discrimination factor is:

$$(OR_{\text{bone-soil}}) = (M_f \times 0.025) + (R_f \times 0.175)$$

in which M_f and R_f are the fractions of dietary calcium derived from dairy products and from other sources, respectively.

Discrimination ratios of Sr⁹⁰/Ca for various countries, derived from per capita consumption of principal foodstuffs^{29,30} and their average calcium content,³¹ are given in Table 5. The over-all discrimination ratio varies from about 0.04 for countries with high milk consumption (New Zealand, Switzerland, Sweden) to about 0.15 for Far Eastern countries that consume little milk. Discrimination ratios were weighted for the population densities of the various countries to give weighted average values of 0.1, 0.06, and 0.12 for the north temperate latitudes, south temperate latitudes, and rest of the world population, respectively. The discrimination ratios for the various areas are only superficially adjusted for differences in population dietary habits and make no allowance for individual variations in calcium metabolism and for the fraction of Sr⁹⁰ entering the food chain through direct fallout on vegetation. They may be conservative, however, because they are derived on the basis of complete availability of the deposited Sr⁹⁰ and on the assumption that all of man's dietary calcium comes from the top 2.5 in. of the soil.

Average maximum Sr⁹⁰ equilibrium bone levels in the world's population postulated from ecological considerations are given in Table 6. These data suggest the average maximum level of Sr⁹⁰ in the bones of the population of the United States would be about 3.1 μc per gram of Ca, if they were in ecological equilibrium with the 1957 soil deposition levels. The average of the north temperate population belt would be about the same as the United States because of the lower ratio of milk to cereals in the diet of the heavily populated countries of the Far East. The population weighted world average is only slightly lower than the average for the north temperate latitude, which is not surprising since over 80 per cent of the world's population lives in that region.

Table 5— Sr^{90}/Ca DISCRIMINATION RATIOS FOR VARIOUS COUNTRIES DERIVED FROM PER CAPITA CONSUMPTION OF PRINCIPAL FOODSTUFFS

Country	M_f	R_f	OR
Algeria	0.69	0.31	0.060
Argentina	0.79	0.21	0.055
Australia	0.82	0.18	0.050
Austria	0.85	0.15	0.046
Belgium-Luxembourg	0.75	0.25	0.061
Brazil	0.60	0.40	0.084
Bulgaria	0.54	0.46	0.085
Burma	0.33	0.67	0.125
Canada	0.85	0.15	0.046
Chile	0.67	0.33	0.072
China	0.23	0.77	0.140
Columbia	0.67	0.33	0.072
Cuba	0.67	0.33	0.072
Czechoslovakia	0.71	0.29	0.067
Denmark	0.79	0.21	0.055
Egypt	0.57	0.43	0.088
Finland	0.84	0.16	0.047
France	0.75	0.75	0.061
Germany	0.74	0.26	0.063
Greece	0.63	0.37	0.079
Hungary	0.53	0.47	0.094
India	0.51	0.49	0.097
Indochina	0.16	0.84	0.151
Indonesia	0.11	0.89	0.158
Italy	0.62	0.38	0.081
Ireland	0.75	0.25	0.061
Israel	0.73	0.27	0.064
Japan	0.18	0.82	0.148
Malaya	0.19	0.81	0.146
Mexico	0.56	0.44	0.090
Morocco	0.75	0.25	0.061
Netherlands	0.83	0.17	0.049
New Zealand	0.88	0.12	0.041
Norway	0.86	0.14	0.044
Pakistan	0.72	0.28	0.066
Peru	0.41	0.59	0.113
Philippines	0.18	0.82	0.148
Poland	0.55	0.45	0.091
Portugal	0.30	0.70	0.123
Rhodesia	0.41	0.59	0.113
Rumania	0.59	0.41	0.085
Spain	0.50	0.50	0.099
Sweden	0.87	0.13	0.043
Switzerland	0.87	0.13	0.043
Thailand	0.55	0.45	0.091
Turkey	0.37	0.63	0.119
Union of South Africa	0.71	0.29	0.067
United Kingdom	0.81	0.19	0.052
United States	0.80	0.20	0.053
Uruguay	0.82	0.18	0.050
Venezuela	0.75	0.25	0.061
Yugoslavia	0.67	0.33	0.072

Table 6—POSTULATED AVERAGE MAXIMUM EQUILIBRIUM Sr⁹⁰ BONE LEVELS
IN THE WORLD POPULATION
($\mu\text{mc/g}$ Bone Ca)

	Mid-1957		About 1963*		About 2050†	
	Ecol. data	Bone data	Ecol. data	Bone data	Ecol. data	Bone data
United States	3.1	1.7	3.5	1.9	31	17
North temperate latitude	3.2	1.7	3.6	1.9	32	17
South temperate latitude	0.6	0.5	0.7	0.6	6	5
Rest of world	0.8	0.3–0.5	0.9	0.5–0.8	8	3–5
World average‡	(2.8)	(1.5)	(3.1)	(1.7)	(28)	(15)

* Assuming no more weapons tests.

† At equilibrium with a continued test rate of 10 MT equivalents of fission per year.

‡ Population weighted average.

An alternative method of estimating average maximum equilibrium bone levels involves the use of current Sr⁹⁰ bone analyses, by adjusting the data for the pronounced variation in Sr⁹⁰/Ca ratio in bone as a function of skeletal age. Langham and Anderson³² estimated the fraction of Sr⁹⁰/Ca skeletal equilibrium from the rate of skeletal accretion³³ and the rate of increase in integrated fallout shown in Fig. 4. It was assumed that each yearly increment of skeletal growth contains Sr⁹⁰ at a concentration corresponding to the Sr⁹⁰ build-up in the biosphere for that year. For a first approximation, the skeleton was regarded as a unit and the Sr⁹⁰ burden averaged over the entire skeleton.

Calculated values for the apparent fraction of equilibrium Sr⁹⁰/Ca ratio as a function of age, based on skeletal growth rate alone and a yearly doubling time of the Sr⁹⁰ level are shown by the solid curve of Fig. 5. The points represent Kulp's 1955-1956 data⁶ normalized to the 0- to 4-year age group as representing 59 per cent of equilibrium Sr⁹⁰ concentration.

At age 24 (4 years beyond the age at which skeletal growth stops) these data show that 7 to 10 per cent of the skeletal calcium was involved in bone remodeling plus exchange during the period of environmental contamination. If an equivalent fraction of the skeletal calcium of growing subjects is involved in exchange plus remodeling, then the Sr⁹⁰ levels in children would be proportionally higher (dashed line, Fig. 5) than the curve based on skeletal calcium accretion alone. This indeed appears to be the case and indicates that the major factors have been considered in constructing the model. The upper curve in Fig. 5 permits the use of adequate bone data from any age group to predict the average maximum equilibrium Sr⁹⁰ bone level and indicates a value of 0.9 μmc per gram of Ca by the end of 1955.

Strontium-90 content of skeletons of stillborns¹² during 1955 averaged about 0.5 μmc per gram of Ca, which gives an average maximum equilibrium level of 1.0 when the placental discrimination factor of 0.5 is considered.³⁴ Bryant et al.³⁵ in England reported analyses of 28 bone samples from subjects of all ages collected about January of 1956. Eight samples from persons ranging from 3 months to 3½ years old (average 1½ years) averaged 0.9 μmc of Sr⁹⁰ per gram of Ca, and 11 subjects ranging from 20 to 65 years of age (average 36 years) averaged 0.07 μmc of Sr⁹⁰ per gram of Ca (after dividing all rib results by 2).⁶ The predicted average maximum Sr⁹⁰ equilibrium levels about January 1956, based on these age groups, are 1.0 and 0.9 μmc per gram of Ca, respectively.

On the assumption that surface deposition levels had a doubling time of one year, an average maximum bone equilibrium level of 1.8 μmc per gram of Ca was predicted for the north temperate latitudes for the fall of 1956.³² Data on Sr⁹⁰ fallout from pot collection samples in New York and Pittsburgh⁵ show, however, that fallout did not double but increased by only about 50 per cent. On this basis, the predicted level for the north temperate population belt in the fall of 1956 would be 1.4 μmc per gram of Ca. Kulp²⁸ applied the same age weighting method to 1956-1957 milk data (assuming a bone-to-diet discrimination ratio of 0.25) and estimated average maximum equilibrium bone levels (by the end of 1956) of 1.1, 0.9, 1.1, and 0.5 for North America, Europe, Asia, and the rest of the world, respectively. A crude estimate of present and future average maximum equilibrium bone levels can be made from the 1956 data

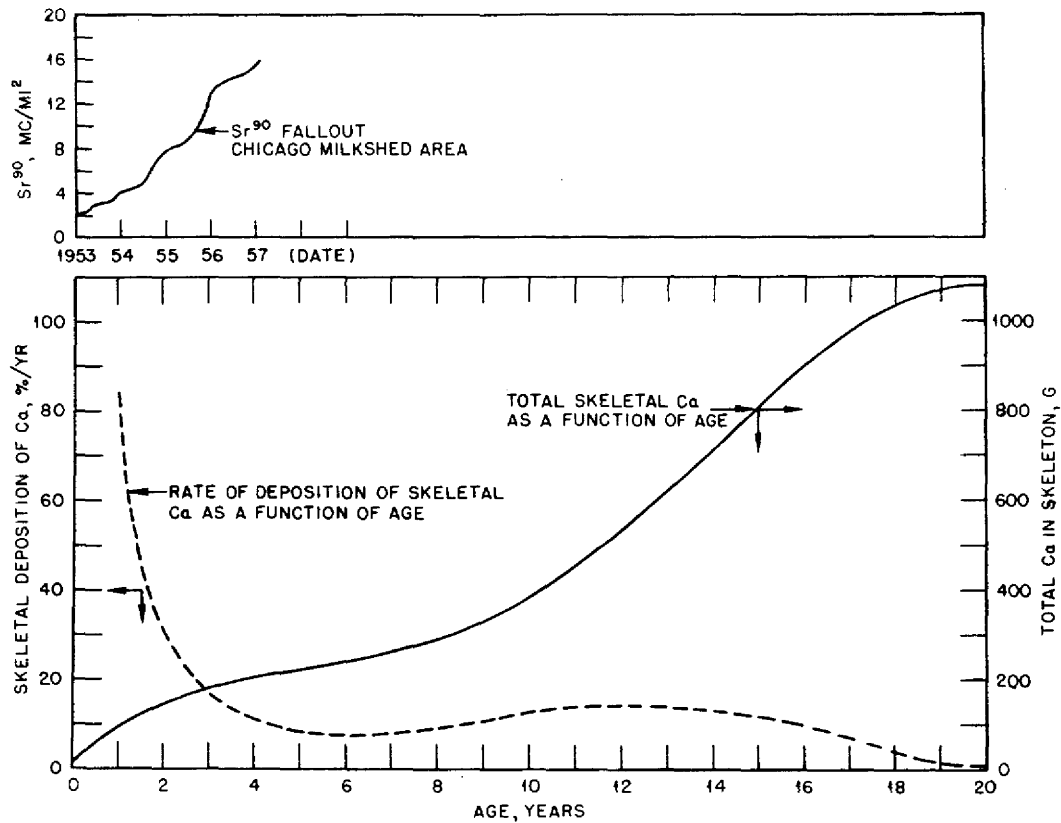

Fig. 4—Rate of skeletal accretion in relation to rate of environmental contamination.

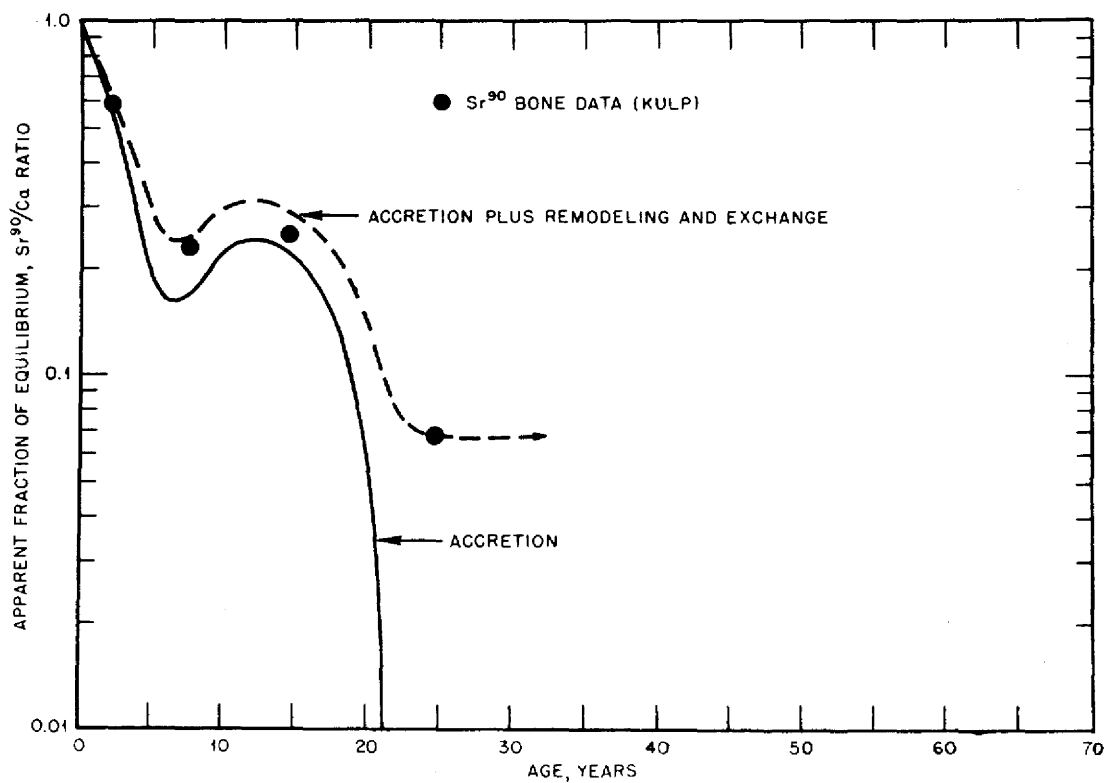

Fig. 5—Apparent fraction of equilibrium Sr^{90}/Ca ratio in relation to skeletal age.

by assuming they will be proportional to the predicted average maximum surface deposition levels given previously. These estimates are compared in Table 6 with those postulated from ecological considerations. Values postulated from ecological discrimination and from bone analyses differ by a factor of about 2. This discrepancy results mostly from the weighted influence of the Far Eastern countries, with low milk consumption and large populations, on the discrimination ratios. Although bone data are probably more reliable than ecological predictions, they may be low since they were predicted on the assumption that the analyses represented the average bone levels for the various regions. Since the number of samples from the United States and Europe exceeded the number from countries with large populations and low relative milk consumption, it is unlikely that they are weighted adequately for population density and dietary habits.

Another troublesome feature of such estimates is that they are average maximum equilibrium levels and make no allowance for such factors as local variations of fallout due to meteorological factors, variations in available soil calcium, dietary patterns and habits, nutritional state of segments of the population, and individual metabolic condition.

Frequency distribution patterns have been reported for stable strontium,³⁶ natural radium,³⁷ and Cs¹³⁷ (reference 7) in man. All these nuclides show essentially normal distributions with standard deviations of about 35 per cent. Libby¹³ has stated that (at steady state among people living in a given locality) only one person in about 700 will have more than twice the average Sr⁹⁰ burden, and the chances of anyone having as much as three times the average will be about one in 20 million. At present, the Sr⁹⁰ measurements of bone samples from subjects of all ages show a much greater scatter than indicated by a standard deviation of 35 per cent. The greater scatter of the observed values is due largely to the fact that samples came from many localities and (because of the relatively short period of environmental contamination and the age dependence of Sr⁹⁰ deposition) represent varying degrees of equilibrium conditions. The spread may be expected to decrease as equilibrium is approached.^{13,28}

Local meteorological conditions will result in increased intensity of fallout in certain localities. The worst possible situation that could come about would be for these "hot spots" to coincide with localities of low available soil calcium in which the population grew up and lived in provincial isolation. Libby¹³ has considered this problem in view of the general averaging which occurs in food distribution systems and has postulated that a factor of 5 encompasses the total variation due to all factors.

The question as to the applicability of the normal distribution curve to Sr⁹⁰ equilibrium levels in bone has been raised.^{38,39} The observed distribution of stable strontium in bone³⁶ appears to be log normal rather than normal; in fact the former is rather common for geochemical distribution.⁴⁰ The great fundamental difference in the mechanisms of distribution of stable strontium and Sr⁹⁰, however, greatly weakens arguments based on the analogy. Whether the distribution of equilibrium levels in the bones of the population will be normal or log normal can probably be decided only by more extensive experimental evidence.

4.2 Cesium-137

(a) *Ecological Incorporation and Discrimination.* Cesium is chemically and metabolically similar to potassium, an essential body constituent. If it enters the food chain from the soil (rather than by direct fallout on plants), its uptake via the ecological cycle and incorporation into man should be in relation to the exchangeable or available soil potassium. It is reasonable, therefore, to consider incorporation of Cs¹³⁷ into the biosphere in terms of Cs¹³⁷/K ratios. Like Sr⁹⁰, Cs¹³⁷ may be incorporated through direct fallout on vegetation and through soil accumulation and uptake by plants. When Cs¹³⁷ comes in contact with soil, it is rapidly fixed. Leaching studies⁴¹ show essentially all of the Cs¹³⁷ remains in the top inch of soil, even after 200 in. of simulated rainfall. The extent of fixation, as with potassium, is probably proportional to the colloidal content of the soil, being greatest in clays and clay loams and least in light sands and sandy loams.

Plants discriminate heavily against Cs¹³⁷ with respect to potassium, even when the cesium is in an exchangeable form. Auerbach⁴² reported uptake of Cs¹³⁷ by corn grown in a lake bed once used for the disposal of reactor wastes. He found that the Cs¹³⁷/K ratio in the plants was about 1 per cent of the exchangeable Cs¹³⁷/K ratio in the soil. Menzel⁴³ obtained a discrimination factor of about 0.04 between Cs¹³⁷/K in barley and corn and the ratio in available soil

potassium, and definitely showed that plant uptake of Cs^{137} was inversely proportional to exchangeable and available soil potassium. Without considering exchangeable soil potassium, others^{44,45} have studied the ratio of Cs^{137} per g of dry plant materials to the concentration per g of soil and obtained values of 0.006 to 0.18 (average 0.07). These data suggest that the average Cs^{137} concentration in the potassium of plants should be about 0.04 times the exchangeable Cs^{137} concentration in exchangeable soil potassium.

Exchangeable soil potassium, to a depth of 2.5 in., may vary from about 25 to 400 lbs/acre. About 100 lbs/acre is a reasonable average value for the agricultural soils of the United States. This is equivalent to about 3×10^7 g of exchangeable K/sq mile. Deposition and mixing to a depth of 2.5 in. of 1 mc of Cs^{137} per square mile gives a total concentration of about 30 $\mu\mu\text{c}$ per gram of exchangeable soil potassium. Larson et al.⁴⁶ added Cs^{137} to three different types of soils and determined the amount that could be extracted with $\text{N NH}_4\text{Ac}$. The exchangeable Cs^{137} ranged from 13 to 33 per cent with an average of 25. Assuming that 75 per cent of the Cs^{137} is fixed in a form unavailable to plants, the discrimination factor (DF_1) in going from soils-to-plants would be equal to 0.01 and the concentration of Cs^{137} in plant potassium from fallout of 1 mc/sq mile would be about 0.3 $\mu\mu\text{c/g}$.

The Cs^{137} deposition level in the northern United States (mid-1957) is estimated at about 46 mc/sq mile, which suggests 15 $\mu\mu\text{c}$ Cs^{137} per gram of plant potassium, or a $\text{Cs}^{137}/\text{K}^{40}$ gamma ratio of 0.18. The calculated ratio is in reasonable agreement with values measured in the Los Alamos large-volume liquid scintillation counter.⁷ Measured $\text{Cs}^{137}/\text{K}^{40}$ ratios in 1957 dried milk samples from the northern United States⁴⁷ averaged about 30 $\mu\mu\text{c/g}$, giving an estimated discrimination factor (DF_2) of about 2 in favor of Cs^{137} in going from plants-to-milk.

Tracer studies on man⁴⁸ show that Cs^{137} and K^{42} , upon ingestion, are absorbed essentially 100 per cent and that they are excreted with mean times of about 150 and 50 days, respectively. These data suggest a discrimination factor of about 3 in favor of Cs^{137} in going from diet (DF_3 and DF_4) to man.* Since 50 per cent of the potassium in a western diet comes from milk and dairy products,⁷ the over-all ratio (OR) of Cs^{137}/K is going from soils-to-man equals 0.5 ($0.01 \times 2 \times 3$) + 0.5 (0.01×3), or 0.045. In other words, the Cs^{137} concentration per gram of body potassium should be about 4.5 per cent of the total Cs^{137} concentration per gram of exchangeable soil potassium.

Anderson et al.⁷ suggested that Cs^{137} may be entering the biosphere and man largely through direct fallout on vegetation and not by plant uptake from the soil. This suggestion was based on the following considerations: (1) The high fixation of Cs^{137} in soil and its very slow leaching rate make it unlikely that the Cs^{137} can be in equilibrium with exchangeable soil potassium to the depth of the plant feeding zone. (2) The $\text{Cs}^{137}/\text{K}^{40}$ ratio of people does not seem to be increasing in relation to integrated Cs^{137} fallout. (3) $\text{Cs}^{137}/\text{K}^{40}$ ratios in milk show sharp increases during periods of weapons testing, after which they rapidly return to near their previous levels, suggesting the possibility of a quasi-equilibrium condition with the rate of stratospheric fallout. The relatively small effect of a sharp increase in the Cs^{137} content of foods during periods of tropospheric fallout on the Cs^{137} content of people can be explained by the simple model shown in Fig. 6 (reference 7). A step function change in the foodstuff level will be followed by a $(1 - e^{-\lambda t})$ change in the population level (where λ is the biological elimination rate), and a new equilibrium value will be reached only after an elapsed time of about one year. If the foodstuffs return to their previous value before equilibrium is attained, the population level will cease rising and will return to its previous value with a half-time corresponding to the biological elimination rate.

(b) Cs^{137} Levels in the Population. Concentrations of Cs^{137} per gram of body potassium can be estimated from predicted average maximum surface deposition levels given in Tables 2, 3, and 4 and the ecological considerations discussed previously. One millicurie of Cs^{137} per square mile gives a specific activity of 30 $\mu\mu\text{c}$ per gram of exchangeable soil potassium. The specific activity times the surface deposition levels times the over-all discrimination ratio (0.045) gives the specific activity per gram of body potassium for the population of any fallout area, assuming no equalization between areas through food distribution channels.

*A value of 3 for the discrimination factor from milk-to-man (DF_3) is not confirmed by measurements on people and milk from the same areas.⁴⁷ These data strongly suggest a discrimination factor of approximately one.

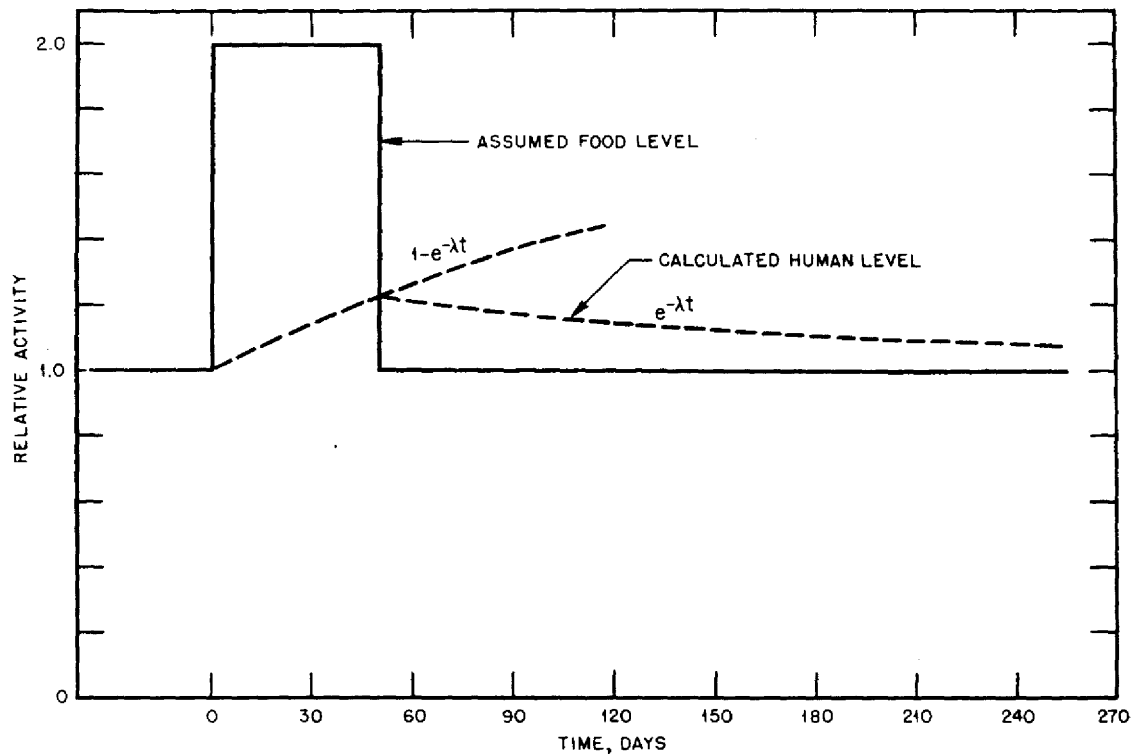

Fig. 6—Calculated effect of temporary increase in Cs^{137} level of the diet on the Cs^{137} level in people.

Table 7—ESTIMATED PRESENT AND FUTURE CONCENTRATIONS OF Cs^{137} IN THE POPULATION ON THE BASIS OF ECOLOGICAL CONSIDERATIONS

Region	Cs^{137} concentration		
	Mid-1957, $\mu\mu\text{c/g of K}$	1965—No more tests, $\mu\mu\text{c/g of K}$	Continued tests,* $\mu\mu\text{c/g of K}$
Northern United States	62	69	620
North temperate latitudes	34	37	340
South temperate latitudes	10	11	100
Rest of world	7	8	70
World average†	(32)	(36)	(320)

* Assuming equilibrium with continued testing at the past 5-year rate (equivalent to 10 megatons of fission per year).

† Population weighted average on the basis of present world population distribution.

Present and future levels of Cs^{137} in the population of various regions, estimated from ecological considerations, are shown in Table 7.

Measurements of $\text{Cs}^{137}/\text{K}^{40}$ gamma ratios of the United States population during 1956 averaged about 0.5 (reference 7), which corresponds to $41 \mu\mu\text{c}$ Cs^{137} per gram of body potassium or about $0.0055 \mu\text{c}$ of Cs^{137} in the total body assuming 133 g of potassium in a 70-kg man. Measurements during 1957 (reference 47) gave average Cs^{137} concentrations of 45 and 50 $\mu\mu\text{c}/\text{g}$ of body potassium for the general United States population and the population of the northern states, respectively. Levels in the United States population might be expected to show little variation because of the equalizing effect of general food distribution systems.

The value of 62 $\mu\mu\text{c}$ per gram of K for the population of the northern United States, estimated from ecological considerations, agrees very well with the average value of 50 $\mu\mu\text{c}$ per gram of K derived from measured $\text{Cs}^{137}/\text{K}^{40}$ ratios. The agreement may be purely coincidental and could result from direct fallout on vegetation, fortuitously making up for non-equilibrium of Cs^{137} with exchangeable soil potassium.

The estimates of future levels given in Table 7 are predicated on the assumption that Cs^{137} is entering the biosphere largely through the soil and that the contribution of direct fallout on vegetation is negligible. In this case, Cs^{137} levels in people might be expected to rise somewhat in accordance with the estimated values. If present levels represent a quasi-equilibrium with direct fallout, population levels (with cessation of testing) might be expected to start dropping immediately with a half-time comparable to the half-time of stratospheric fallout. In this case, continued testing at the past 5-year rate will produce little or no increase in the average Cs^{137} of the population. Present levels in the biosphere actually may be a result of significant contribution from both direct fallout and ecological integration, in which case the truth will be somewhere in between. It should be possible to decide among these alternatives within the next few years.

4.3 Plutonium-239

Ecological Incorporation and Discrimination. Although the presence of naturally occurring Pu^{239} in pitchblende concentrate has been reported,⁴³ its existence in the biosphere can be attributed entirely to the detonation of nuclear weapons. Unlike Sr^{90} and Cs^{137} , it is chemically unrelated to any essential constituent of plants or animals.

When plutonium is deposited in soil it is extremely tightly bound, and the establishment of uniform distribution to the depth of the plant feeding zone may require years. A plutonium deposition level of 1 mc/sq mile would be equivalent to about $5 \times 10^{-3} \mu\mu\text{c}$ per gram of soil when uniformly mixed to a depth of 2.5 in. Absorption of plutonium by barley from a sandy soil was studied by Rediske,⁴⁴ who found that the ratio of plutonium concentration in dry plant material to the concentration in the soil was 9×10^{-4} . When ingested by man and domestic animals, absorption of plutonium is only about 0.01 per cent. Once it is absorbed, about 85 per cent is fixed in the skeleton and largely retained throughout the life-time of the animal. The apparent half-time of plutonium elimination by man is about 200 years, which means it is essentially completely cumulative on absorption. Its high fixation in the skeleton of domestic animals, however, provides an additional discrimination factor of about 10^{-2} in meat and dairy products. The over-all discrimination ratio in going through the ecological cycle from soils to man is at most 5×10^{-8} . The estimated present average maximum plutonium deposition level for the north temperate population belt would lead to a plutonium uptake of the order of 10^{-7} of the recommended maximum permissible level from the consumption of a 3000-calorie diet for 70 years. With such a large discrimination, it is quite unlikely that incorporation of plutonium fallout into man via the ecological chain can be of any consequence. Incorporation via inhalation and direct fallout on vegetation, although insignificant also, probably would be much greater than incorporation via ecological transport.

4.4 Iodine-131

Radioactive iodine from weapons tests has been reported in human thyroids^{50,51} and in the thyroids of domestic animals.⁵⁰⁻⁵⁴ Because of its 8-day half life, I^{131} cannot integrate in the biosphere and its concentration in thyroids fluctuates in relation to tropospheric fallout during

periods of nuclear testing. Van Middlesworth⁵⁰ reported the analysis of 175 human and 1044 cattle thyroids collected from the Memphis, Tenn., area during November 1954 to March 1956, and Comar et al.⁵¹ reported analysis of 1165 human and 853 cattle thyroids collected from several countries during the period from January 1955 to December 1956. These data show that the concentration of I^{131} in cattle thyroids is about 18 to 200 times that of man. The average concentration in cattle thyroids during the period from November 1954 to December 1956 appears to be about 0.5 (reference 54) and the average peak level in man about 0.005 $\mu\mu\text{c/g}$.⁵¹

The principal mode of entry of I^{131} into domestic animals seems to be through ingestion of direct fallout on forage. Grazing animals show a much higher thyroid uptake than do lot fed. The mode of entry of I^{131} into man is believed to be via direct inhalation with ingestion of contaminated milk as a secondary route. Following oral feeding to cattle, about 6 per cent of the ingested I^{131} appears in the first week's milk production.⁵⁵ The average milk concentration during the 1955 period of high level fallout was estimated at about 0.2 $\mu\mu\text{c/liter}$, which is a factor of 500 below the value chosen as unsafe for public consumption during the recent United Kingdom Windscale reactor accident.⁵⁶

Since I^{131} does not accumulate in the biosphere, the above values may be considered crude average maximum equilibrium levels with the present rate of testing. Although large local fluctuations may be expected from time to time as a result of tropospheric meteorological variations and proximity to test sites, the average I^{131} content of the thyroids of man and livestock should not increase materially with continued testing at the past 5-year rate.

One $\mu\mu\text{c}$ of I^{131} per g of thyroid delivers a radiation dose of about 10 mrad/day.⁵³ The average I^{131} concentrations during the 1955 peak period of fallout delivered about 35 and 0.3 mrad/week to livestock and man, respectively. The integrated dose received during 1955 was actually much lower.⁵¹

If the 1955 peak levels are maintained in people and livestock, the yearly integrated dose to the thyroid will be about 15 and 1500 mrad/year, respectively. For man, this is about one per cent of the recommended maximum permissible level for continuous exposure of large segments of the population.

The external radiation dose to the neck area in infants and children that possibly has caused later thyroid malignancy is estimated at 200 to 750 r (reference 57), and about 900 rad to the thyroids of sheep chronically fed I^{131} over a 6-year period failed to produce any observable damage.⁵⁸

In the event of nuclear war, it is conceivable that I^{131} could constitute a significant acute danger in localized areas. However, there seems to be very little probability that I^{131} levels introduced into the biosphere by continuation of weapons tests at the past rate will pose any general hazard to man and domestic animals.

5 SIGNIFICANCE OF Sr^{90} AND Cs^{137} LEVELS IN THE POPULATION

5.1 Strontium-90

The potential significance of present and predicted Sr^{90} levels in bone can be evaluated only in relation to human experience, which is indeed inadequate. Bone sarcoma has resulted from a fixed skeletal burden of 3.6 μc of pure Ra^{226} , and nondeleterious bone changes have been observed in persons having only 0.4 μc for a period of 25 years.⁵⁹ Necrosis and tumors of the bone have occurred also several years after large doses of X rays,⁶⁰ and consideration of human experience with leukemogenic effects of X and gamma radiation⁶¹⁻⁶³ suggests that about 80 rads may double the incidence of leukemia.

The only other human experience with which present and predicted levels of Sr^{90} may be compared is that arising from natural background radiation. Natural background dose to the bone (during a 70-year lifetime) may vary from about 8 to 38 rem.⁶⁴ The major contribution to background variation is differences in the radium levels of soils and minerals. The average natural skeletal radiation dose rate was carefully evaluated by Dudley and Evans⁶⁵ and their data are shown in Table 8.

Figure 7 shows a general summary of estimated skeletal radiation doses from accepted maximum permissible levels and from present and predicted Sr^{90} burdens in relation to human experience. The maximum permissible level of Sr^{90} (100 $\mu\mu\text{c}$ per gram of Ca) is estimated to

Table 8—AVERAGE NATURAL BACKGROUND RADIATION TO THE SKELETON⁶⁵

Source of radiation	Skeletal dose rate, mrem/year	Total dose, to age 70 rem
K ⁴⁰ (internal)	8	0.56
Ra ²²⁶ (internal)	12	0.84
MsTh (internal)	12	0.84
RaD (internal)	12	0.84
Cosmic rays (external)	30	2.10
Local gamma rays (external)	60	4.20
Total	134	9.40

deliver about 8.5 rads* to the skeleton during a 70-year lifetime. This is comparable to the average natural background dose to the bone for the same time period and a factor of about 4 below the maximum natural background dose to which small segments of the general population may be exposed as a result of differences in altitude and natural radium content of soils and minerals. It is a factor of 40 below the lowest skeletal dose which has produced minimal

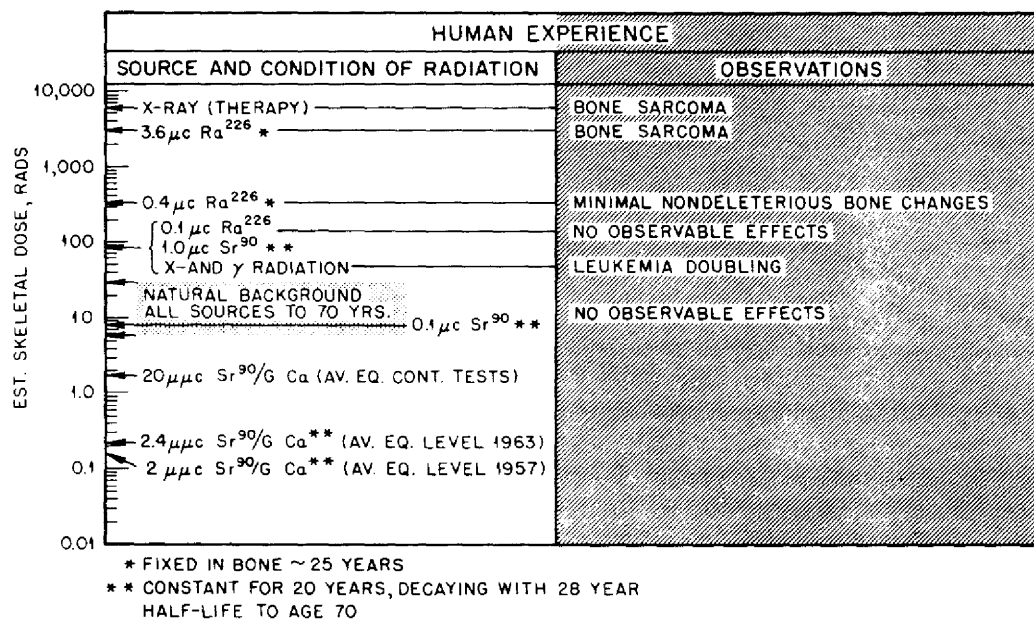

Fig. 7—Estimated Sr⁹⁰ skeletal radiation dose in relation to human experience.

nondeleterious bone changes and a factor of about 10 below the leukemia doubling dose. These data suggest that the present average maximum Sr⁹⁰ equilibrium level will result in a lifetime radiation dose of 1 to 2 per cent of the accepted maximum permissible level for the general population. With continued biospheric contamination indefinitely at the past 5-year rate, the average maximum radiation dose may approach about 20 per cent of the presently accepted maximum permissible level.

*Eight and five-tenths rads is the calculated dose assuming incorporation to age 20 and decay to age 70 with no more incorporation. If equilibrium were maintained, the calculated skeletal dose would be about 21 rads. Since some but not all of the skeleton undergoes remodeling plus exchange, somewhere between 8 and 21 rads is probably more correct.

Threshold versus Nonthreshold Response. If chronic effects of radiation are threshold phenomena, 100 $\mu\mu\text{c}$ of Sr^{90} per gram of Ca must be looked upon as a true maximum permissible level and not as an average for large segments of the population. If chronic effects are nonthreshold phenomena and linear with dose (Fig. 8), the maximum permissible level of Sr^{90} in the bones may be expressed in terms of a population or group average, and a portion of the natural population incidence of the effect in question must be attributed to natural background radiation. In this case, the potential hazard should be established on the basis of probability of risk averaged over the entire population or group.

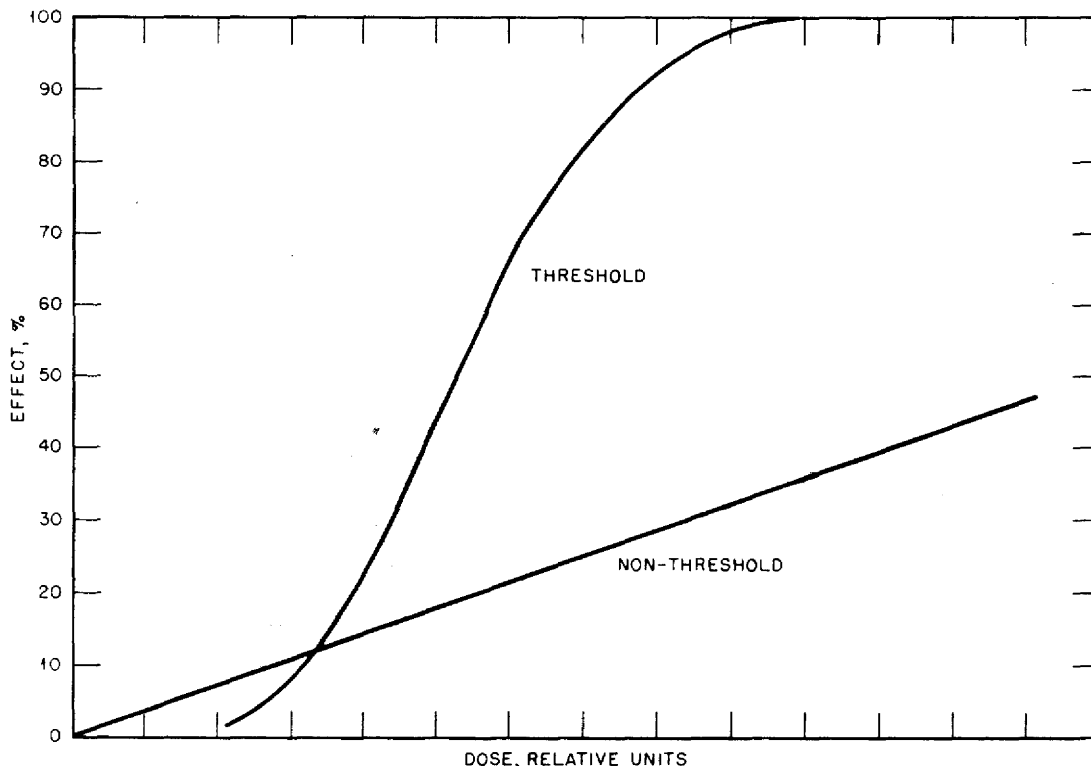

Fig. 8—Threshold and nonthreshold response as a function of radiation dose.

At present it is impossible to say whether leukemogenic and sarcogenic responses to chronic radiation dosage are threshold or nonthreshold relationships. The recent Congressional Hearings¹ failed to produce any degree of unanimity of opinion among the experts. Argument for a linear relationship between incidence of leukemia and radiation dose was presented recently by Lewis.⁶² His argument was based on all major sources of human data and included a consideration of the Japanese atomic bomb survivors, the British cases of X-ray treated spondylitis, X-ray treated cases of thymic enlargement, practicing radiologists, and spontaneous incidence of leukemia in Brooklyn, New York. The validity of his conclusion was questioned by Warren, Brues, and others during the Congressional Hearings.¹ Radiation as a carcinogenic agent has been discussed at length by Brues,⁶⁸ who stated that the relation between radiation dose and carcinogenic effect is not easy to find and a critical experiment has yet to be done which will clearly indicate, even in a single instance, what the relation is over more than a small range of dosages. While admitting that it is not known, he proposes that a threshold relationship between radiation dose and tumor incidence does exist.⁶⁷

Without adequate scientific basis but for the purpose of presenting the worst possible potential hazard from Sr^{90} biospheric contamination, a comparison may be made between the radiation dose from present Sr^{90} bone levels and the postulated leukemia doubling dose.⁶² Assuming a nonthreshold response and that 10 per cent of the natural incidence of leukemia in the population (6/100,000) is a result of natural background radiation, the average maximum Sr^{90} equilibrium bone level for the north temperate population belt would be equivalent to about

1.2 leukemia cases per 10 million population. Averaged over the world population of 2.6 billion, this would produce an increased leukemia burden of 300 cases per year. A world average of 100 $\mu\mu\text{c}$ of Sr^{90} per gram of Ca would be equivalent to about 16,000 cases.

The above analogy assumes that Sr^{90} beta radiation induces leukemia of bone marrow origin at the same rate (per unit of absorbed dose) as X and gamma rays. Much of the beta radiation from Sr^{90} will be absorbed in the bone and not reach the hematopoietic tissues at all. Experiments by Brues et al.⁶⁸ suggest that Sr^{89} (half-life 55 days, $E_{\beta} = 1.5$ Mev) administered to mice is relatively more spectacular as an osteosarcogenic agent than a leukemogenic agent. Furthermore, leukemia was not a significant finding in the radium dial painters^{69,70} or in the radium-injection cases.⁵⁹

Bone sarcoma is more apt to result from Sr^{90} than is leukemia. Human data on radiation-induced osteogenic sarcoma are not adequate to provide even the crudest estimate of the dose response relationship, the population doubling dose, or the fraction of normal population incidence (about 2/100,000) attributable to natural background.

Under the same conditions, the potential risk to the population from bone sarcoma, however, would be less than that calculated for leukemia, since its natural incidence in the population is lower than that of leukemia.

Table 9—CONCENTRATION OF Cs^{137} IN THE GONADS OF RATS

Days after administration	Concentration gonads/muscle*
Testes	
2	0.70
5	0.71
10	0.52
Ovaries	
2	0.82

* Average of three animals per point.

5.2 Cesium-137

The present average Cs^{137} level in the population of the United States is about 45 $\mu\mu\text{c/g}$ body potassium. This is equivalent to 0.006 μc per person. Cs^{137} , like potassium, is concentrated in muscle and the radiation dose it delivers is essentially whole-body. The dose delivered is equivalent to approximately 1 mr/year. Taking into consideration the respective energies of their radiations, the dose from the present level of Cs^{137} is about one-twentieth of that from natural K^{40} , or about one per cent of the average natural background. If Cs^{137} is entering man largely through the ecological cycle, continued testing at the past 5-year rate may result in an average radiation dose to the United States population of about 10 mr/year, or about 10 per cent of natural background, and a weighted world population average of about 7 per cent of background. Because of nonhomogeneities in fallout and uptake, a few persons may receive doses about 5 times the average. If Cs^{137} is entering man largely through direct fallout on vegetation and not through ecological integration, continued testing may not increase the average Cs^{137} dose significantly above the present levels.

Concern has been expressed⁷¹ over the possible genetic implications of selective concentrations of Cs^{137} in the gonads. The data in Table 9 show the ratio of Cs^{137} concentration in the gonads of rats to that in muscle. The testes and ovaries concentrate Cs^{137} to the extent of about 70 and 80 per cent of muscle, respectively, and the elimination time from the testes appears shorter. Therefore, the radiation dose delivered to the gonads is comparable to that delivered to muscle, or about 2 mr/year at present United States average Cs^{137} levels.

6 DISCUSSION AND SUMMARY

Past testing of nuclear weapons has produced between 5 and 6 megacuries of Sr^{90} (equivalent to 50 to 60 megatons of fission energy). About 90 per cent of the production has occurred

since 1952 from testing of weapons in the megaton class. United States Pacific tests have been held under conditions that maximized local fallout (where Sr^{90} is of no concern because of the vast calcium reservoir of the ocean) and minimized world-wide contamination. Soil data suggest that about 1.6 megacuries of Sr^{90} have been distributed as long-range fallout. The present stratospheric reservoir is estimated at about 2.4 megacuries by Libby,¹² and at 1.1 ± 0.93 in this report. Present integrated surface deposition levels are such that the rate of Sr^{90} decay on the ground is almost equal to the rate of stratospheric fallout. If weapons tests were to stop, integrated surface deposition levels in the north temperate latitudes would probably increase by no more than 10 per cent, reaching a maximum in about 1963-1970.

Unfortunately, because of the locations of the United States and USSR test sites and tropospheric and stratospheric meteorological phenomena, long-range fallout is maximized in the north temperate latitudes where over 80 per cent of the world's population lives. The present average soil level in the northern United States is about 35 mc/sq mile, and the average level elsewhere in the same general latitudes may be about 20 mc/sq mile. Deposition levels elsewhere in the world are not potentially important with regard to general world health because of population distribution.

Estimates of average maximum Sr^{90} equilibrium bone levels for the northern United States and the north temperate population belt (from weapons tests to date) vary from about 1 to 4 μmc per gram of Ca. Controversy over the issue of stopping or continuing bomb tests has resulted in greater apparent public confusion over the potential hazard of world-wide Sr^{90} fallout than seems justified by the factor of 4 differences in estimates of average maximum equilibrium bone levels. This confusion has resulted largely from differences in choice of reference as to average maximum permissible Sr^{90} levels applicable to the general population and differences in opinion as to an appropriate factor of allowance for nonhomogeneity of fallout and bone uptake.

Libby^{5,12} and Kulp,⁷² before any authoritative statements regarding a Sr^{90} MPL for the general population had been issued, used the occupational MPL (1000 μmc per gram of Ca) as a reference. Later the National and International Commissions for Radiological Protection recommended that the MPL for large segments of the general population should be one-tenth (100 μmc per gram of Ca) that for occupational exposure. The U. S. National Academy of Sciences-National Research Council report⁷³ inferred that 50 μmc per gram of Ca might be considered as a safe level for the general population. The British Medical Research Council report,⁶¹ while acknowledging that the maximum allowable concentration of Sr^{90} in the bones of the general population should not be greater than 100 μmc per gram of Ca, stated that immediate consideration should be required if the concentration in human bones showed signs of rising greatly beyond one-hundredth (10 μmc per gram of Ca) of that corresponding to the maximum permissible occupational level. Lapp⁷⁴ has stated also that the MPL for the general population perhaps should be one-hundredth of the occupational value. All of these numbers have been brought to public attention during the controversy over continued weapons tests.¹

Confusion has been increased also by the use of various safety factors for nonhomogeneity of fallout and bone uptake. Articles have appeared in which no factor was used,^{5,6,12} and others have appeared in which factors of 5¹³ and 10^{74,75} were recommended.

The effect of choice of values for the acceptable general population MPL and the choice of safety factors for nonhomogeneity of distribution and uptake are shown by the data in Table 10. These data were derived by simple proportionality (Maximum Bone Level from Present Tests: 50 megatons :: Acceptable MPL: X) and show the megatons of fission energy release (over a short period) required to bring the average maximum equilibrium bone levels of the population to the various permissible values that have been called to public attention. The table also indicates the effect of various nonhomogeneity factors on the world average population level. These data show a variation of a factor of about 1000 in the megaton equivalents of fission that could be detonated, depending on whether one wishes to be ultraconservative and use the highest safety factor for nonuniformity and the lowest value recommended for the general population, or be the opposite and use the occupational MPL and no safety factor for nonuniformity. The most important point to the data is that they explain the principal reasons for public confusion and show that the major areas of uncertainty are: (1) the maximum permissible level for Sr^{90} as applied to the general population; and (2) the deviation of equilibrium bone values from the mean.

Table 10—ALLOWABLE MEGATONS OF FISSION ENERGY RELEASE AS A FUNCTION OF VARIOUS GENERAL POPULATION MPL'S

Source of equilibrium bone level estimate and region	Av. max. bone level (no more testing) $\mu\text{mc/g}$ of Ca	Allowable MT of Fission yield			
		10 $\mu\text{mc/g}$ of Ca	50 $\mu\text{mc/g}$ of Ca	100 $\mu\text{mc/g}$ of Ca	1000 $\mu\text{mc/g}$ of Ca
<u>United States</u>					
Libby (13)-Ecological data	3.9-1.7	130-300	650-1500	1300-3000	13,000-30,000
Kulp (6)-Ecological data	2	250	1250	2500	25,000
Kulp (28)-Bone data	1.5	300	1500	3000	30,000
Eisenbud (76)-Milk data	4	120	600	1200	12,000
This paper-Ecological data	3.5	140	700	1400	14,000
This paper-Bone data	1.9	250	1250	2500	25,000
<u>North Temperate Latitudes</u>					
This report-Ecological data	3.6	140	700	1400	14,000
This report-Bone data	1.9	250	1250	2500	25,000
<u>World Average</u>					
Kulp (6)-Ecological data	1.3	380	1900	3800	38,000
This report-Ecological data	3.1	160	800	1600	16,000
This report-Bone data	1.7	150	1500	3000	30,000
World Average (no factor for distribution)	2	250	1250	2500	25,000
Average $\times 1/5$ (for nonuniformity)		50	250	500	5,000
Average $\times 1/10$ (for nonuniformity)		25	125	250	2,500

The most important question regarding the potential hazard of long-range Sr^{90} fallout is in relation to future weapons testing. If there is an upper limit to the amount of Sr^{90} in the bones of the population that can be safely tolerated, then the megaton equivalents of fission products that can be contributed per year to the biosphere by all nations is limited.

If Sr^{90} contamination from weapons testing by all nations continues at the same rate as has occurred during the past 5 years, equilibrium will be reached in about 100 years. At equilibrium the amount of Sr^{90} which will disappear each year from the environment, due to radioactive decay, will equal the amount that is being produced, and continuing weapons tests will not result in any further increase in the population bone levels.

Libby^{13,17} and others¹⁸ have predicted that soil and bone levels at equilibrium with the present test rate will be 8 to 13 times the present values. On the basis of present average maximum equilibrium Sr^{90} bone levels postulated from the considerations set forth in this paper, the bones of the United States population will reach a steady state with the present testing rate at a value of 17 to 31 μmc per gram of Ca. The equilibrium value for the weighted average world population will be 15 to 28 μmc per gram of Ca.

Libby¹³ has stated that something between 5 and 20 μmc per gram of Ca would be the average maximum Sr^{90} concentration in the bones of the United States population if testing continued indefinitely at the average rate of the past 5 years. Kulp²⁸ predicted an equilibrium level will be approached in the North American population of about 8 μmc per gram of Ca in about 50 years, and Neuman¹⁸ in testimony before the Congressional Subcommittee suggested equilibrium bone levels of about 90 μmc per gram of Ca may be reached in the northern United States. The values given above show disagreement by a factor of about 10. If, however, we accept as a reasonable average the values developed in this paper, the average Sr^{90} radiation dose to the bones of the population of the northern United States, at equilibrium with continued testing at the past rate, may be about 20 to 30 per cent of the average radiation dose from natural background, or about 20 to 30 per cent of the maximum permissible level adopted by the National and International Commissions. Since individual variations may result in a small number of people accumulating Sr^{90} burdens that are 5 times the average, the radiation dose to these few individuals may approach as an upper limit 100 to 150 per cent of the recom-

mended maximum level. If testing is continued at the present rate for 30 years, the average level of Sr⁹⁰ in the population of the northern United States may be about 10 to 15 per cent of natural background. This may result in a few people approaching body burdens about 50 to 75 per cent of the recommended maximum. Strontium-90 burdens in the weighted world average population will be essentially the same.

The average Cs¹³⁷ levels presently in the population of the United States is about 45 μc per gram of K. This amount of Cs¹³⁷ is delivering a radiation dose of about 1 mr/year, or about 1 per cent of the natural background dose. The present population weighted world average may be about 32 $\mu\text{c}/\text{g}$. Continued testing at the past 5-year rate until equilibrium may result in an average world population Cs¹³⁷ radiation dose of about 7 per cent of background, depending on whether Cs¹³⁷ is entering the biosphere largely via ecological transmission from the soil or by direct fallout on vegetation. In either case, Cs¹³⁷ appears to be relatively less important than Sr⁹⁰ as a potential internal hazard from world-wide fallout. Other long-lived radionuclides, including Pu²³⁹, appear to be orders of magnitude less significant than Sr⁹⁰ and Cs¹³⁷.

These considerations suggest that the past rate of weapons testing, if continued for several years, will not produce internal radiation levels that will exceed the general population maximum permissible levels recommended by the National⁷⁷ and International²¹ Commissions on Radiological Protection. Although this leads to the conclusion that the present rate of biospheric contamination poses no serious potential somatic hazard to world health, the great uncertainties involved make it imperative that the problem be kept under constant scrutiny if weapons tests are to continue. Fortunately, present levels are not critical and the slow rate of biospheric build-up affords time for continued intensive and extensive study.

REFERENCES

1. Hearings before the Special Subcommittee on Radiation of the Joint Committee on Atomic Energy, Congress of the United States, Eighty-Fifth Congress, First Session on The Nature of Radioactive Fallout and Its Effects on Man, Part 1, May 27-29 and June 3, 1957, and Part 2, June 4-7, 1957.
2. R. E. Lapp, Hearings before the Special Subcommittee on Radiation of the Joint Committee on Atomic Energy, Congress of the United States, Eighty-Fifth Congress, First Session on The Nature of Radioactive Fallout and Its Effects on Man, June 4-7, 1957. Part 2, pp. 1261-1262; 1277-1286.
3. Worldwide Effects of Atomic Weapons, Project Sunshine, Rand Corporation Report AECU-3488, August 6, 1953.
4. N. G. Stewart, R. N. Crooks, and E. M. R. Fisher, The Radiological Dose to Persons in the U. K. Due to Debris from Nuclear Test Explosions Prior to January 1956, British Atomic Energy Establishment (Harwell), AERE/HP/R 2017 (1956).
5. W. F. Libby, Radioactive Strontium Fallout, *Proc. Nat. Acad. Sci.* 42, No. 6, 365-390 (June 1956).
6. J. L. Kulp, W. R. Eckelmann, and A. R. Schulert, Strontium-90 in Man. I., *Science* 125, No. 3241, 219-225 (February 8, 1957).
7. E. C. Anderson, R. L. Schuch, W. R. Fisher, and W. H. Langham, Radioactivity of People and Foods, *Science* 125, No. 3261, 1273-1278 (June 28, 1957).
8. C. L. Comar, B. F. Trum, U. S. G. Kuhn III, R. H. Wasserman, M. M. Nold, and J. C. Schooley, Thyroid Radioactivity after Nuclear Weapons Tests, *Science* 126, No. 3262, 16-18 (July 5, 1957).
9. J. B. Hartgering, Hearings before the Special Subcommittee on Radiation of the Joint Committee on Atomic Energy, Congress of the United States, Eighty-Fifth Congress, First Session on The Nature of Radioactive Fallout and Its Effects on Man, May 27-29, and June 3, 1957. Part 1, pp. 725-741.
10. E. C. Anderson, R. E. Schuch, W. R. Fisher, and M. A. Van Dilla, Barium-140 Radioactivity in Foods, *Science* 127, No. 3293, 282-284 (February 7, 1958).
11. F. J. Bryant, A. C. Chamberlain, A. Morgan, and G. S. Spicer, Radiostrontium in Soil, Grass, Milk, and Bone in the United Kingdom, 1956 Results, British Atomic Energy Research Establishment (Harwell), AERE/HP/R 2353 (1957).

12. W. F. Libby, Current Research Findings on Radioactive Fallout, *Proc. Nat. Acad. Sci.* 42, 945-962 (1956).
13. W. F. Libby, (a) Radioactive Fallout, presented before the Spring Meeting of the American Physical Society, Washington, D. C. (April 26, 1957); (b) Isotopes in Meteorology, presented before the American Meteorological Society, Chicago (March 20, 1957).
14. L. Machta, Hearings before the Special Subcommittee on Radiation of the Joint Committee on Atomic Energy, Congress of the United States, Eighty-Fifth Congress, First Session on The Nature of Radioactive Fallout and Its Effects on Man, May 27-29 and June 3, 1957. Part 1, pp. 141-162.
15. E. P. Hardy, Jr., Strontium Program, Summary Report for October 1957, Health and Safety Laboratory Report, New York Operations Office, HASL-1 (October 1957).
16. C. I. Campbell, Radiostrontium Fallout from Continuing Nuclear Tests, *Science* 124, No. 3227, 894 (November 1956).
17. W. F. Libby, Hearings before the Special Subcommittee on Radiation of the Joint Committee on Atomic Energy, Congress of the United States, Eighty-Fifth Congress, First Session on The Nature of Radioactive Fallout and Its Effects on Man, June 4-7, 1957. Part 2, p. 1345.
18. W. F. Neuman, Hearings before the Special Subcommittee on Radiation of the Joint Committee on Atomic Energy, Congress of the United States, Eighty-Fifth Congress, First Session on The Nature of Radioactive Fallout and Its Effects on Man, June 4-7, 1957. Part 2, pp. 1346-1348.
19. W. F. Libby, Hearings before the Special Subcommittee on Radiation of the Joint Committee on Atomic Energy, Congress of the United States, Eighty-Fifth Congress, First Session on The Nature of Radioactive Fallout and Its Effects on Man, June 4-7, 1957. Part 2, p. 1346.
20. E. A. Martell, Project Sunshine Bulletin No. 12: Strontium 90 Concentration Data for Biological Materials, Soils, Water, and Air Filters (August 1, 1956, revised January 1957). Hearings before the Special Subcommittee on Radiation of the Joint Committee on Atomic Energy, Congress of the United States, Eighty-Fifth Congress, First Session on The Nature of Radioactive Fallout and Its Effects on Man, May 27-29 and June 3, 1957. Part 1, pp. 617-650.
21. Recommendations of the International Commission on Radiological Protection, Supplement No. 5, *Brit. J. Radiology* (December 1, 1954).
22. R. Menzel, personal communication to J. L. Kulp, Reference 6, *Science* 125, No. 3241, 219-225 (February 8, 1957).
23. H. Nishita, A. J. Steen, and K. H. Larson, The Release of Sr-90 and Cs-137 from Vina Loam upon Prolonged Cropping, UCLA-380 (November 6, 1956).
24. H. I. Bowen and J. A. Dymond, Uptake of Ca and Sr by Plants and Soils from Nutrient Solutions, *J. Exptl. Botany* 7, 264-272 (1956).
25. G. V. Alexander, Analytical Data presented at the Bio-Medical Program Directors meeting at UCLA (April 29, 1957).
26. C. L. Comar, quoted in Committee Report—Deposition and Retention of Ingested Strontium 90 in the Skeleton, Washington, D. C. (April 23, 1957). Official Use Only.
27. H. Spencer, D. Laszlo, and M. Brothers, Sr-85 and Ca-45 Metabolism in Man, *J. Clin. Invest.* 36, 680-688 (1957).
28. W. R. Eckelmann, J. L. Kulp, and A. R. Schulert, Strontium-90 in Man. II. *Science* 127, No. 3293, 266-274 (February 7, 1958).
29. W. S. Woytinsky and E. S. Woytinsky, World Population and Production, Trends and Outlook, The Twentieth Century Fund, New York (1953).
30. 1955 Year Book of Food and Agriculture Statistics, United Nations-FAO, Rome (1956).
31. Nutritional Charts, Eleventh Edition, Research Dept. of H. J. Heinz Company, Pittsburgh, Pa. (1942).
32. W. H. Langham and E. C. Anderson, Strontium-90 and Skeletal Formation, *Science* 126, No. 3266, 205-206 (August 2, 1957).
33. H. H. Mitchell, T. S. Hamilton, F. R. Steggerda, and H. W. Bean, The Chemical Composition of the Adult Human Body and its Bearing on the Biochemistry of Growth, *J. Biol. Chem.* 158, 625-637 (1945).
34. C. L. Comar, I. B. Whitney, and F. W. Lengemann, Comparative Utilization of Dietary Sr-90 and Calcium by Developing Rat Fetus and Growing Rat, *Proc. Soc. Exptl. Biol. Med.* 88, 232-236 (1955).

35. R. J. Bryant, A. C. Chamberlain, A. Morgan, and G. S. Spicer, Radiostrontium Fallout in Biological Materials in Britain, British Atomic Energy Establishment (Harwell), AERE/HP/R 2056 (1956).
36. K. K. Turekian and J. L. Kulp, Strontium Content of Human Bones, *Science* 124, 405-406 (1956).
37. R. F. Palmer and F. B. Queen, Normal Abundance of Radium in Cadavers from the Pacific Northwest, Hanford Atomic Energy Works Report HW-31242 (1956).
38. E. Dahl, The Dangers from Fallout of Sr-90 after Atomic Bomb Explosions, Translated from paper Teknisk Ukeblad (July 4, 1957).
39. W. F. Neuman, Uncertainties in Evaluating the Effects of Fallout from Weapons Tests, *Bull. Atomic Scientists* 14, No. 1, 31-34 (1958).
40. K. K. Turekian and J. L. Kulp, The Geochemistry of Strontium, *Geochim. et Cosmochim. Acta* 10, 245-296 (1956).
41. C. W. Christenson, E. B. Fowler, G. L. Johnson, E. N. Rex, and F. A. Vigil, The Movement of Strontium-90, Cesium-137, and Plutonium-239 through Tuff Local to the Los Alamos, New Mexico Area, presented at the Third Nuclear Engineering and Science Conference, Chicago (March 1958).
42. S. I. Auerbach, presented at the Oak Ridge National Laboratory, Health Physics Advisory Board meeting (November 18-19, 1957).
43. R. G. Menzel, Competitive Uptake by Plants of Potassium, Rubidium, Cesium, and Calcium, Strontium, Barium from Soils, *Soil Sci.* 77, No. 6, 419-425 (1954).
44. J. H. Rediske, J. F. Cline, and A. A. Selders, The Absorption of Fission Products by Plants, Hanford Atomic Energy Works Report HW-36734 (May 17, 1955).
45. H. Nishita, B. W. Kawalewsky, and K. H. Larson, Fixation and Extractability of Fission Products Contaminating Various Soils and Clays. I. Sr-90, Y-91, Ru-106, Cs-137, and Ce-144, UCLA-282 (1954).
46. E. M. Romney, W. A. Rhoads, and K. Larson, Plant Uptake of Sr-90, Ru-106, Cs-137, and Ce-144 from Three Different Types of Soils, UCLA-294 (June 10, 1954).
47. E. C. Anderson, Los Alamos Scientific Laboratory, unpublished data.
48. C. R. Richmond, Los Alamos Scientific Laboratory, unpublished data.
49. G. T. Seaborg and M. L. Perlman, Search for Elements 94 and 93 in Nature; Presence of 94^{239} in Pitchblende, Paper 1.3, in: *The Transuranium Elements*, McGraw-Hill Book Company, Inc., New York (1949).
50. L. Van Middlesworth, Radioactivity in Thyroid Glands following Nuclear Weapons Tests, *Science* 123, 982-983 (1956).
51. C. L. Comar, B. F. Trum, U. S. G. Kuhn III, R. H. Wasserman, M. M. Nold, and J. C. Schooley, Thyroid Radioactivity after Nuclear Weapons Tests, *Science* 126, 16-18 (1957).
52. R. L. Gunther and H. B. Jones, University of California Report UCRL-2689 (1954).
53. M. R. White and E. L. Dobson, University of California Report UCRL-3355 (1956).
54. A. H. Wolff, Radioactivity in Animal Thyroids, *Public Health Repts. (U. S.)* 72, 1121-1126 (1957).
55. C. L. Comar and R. H. Wasserman, Progress in Nuclear Energy Series VI, 153-196, Pergamon Press, London (1956).
56. Accident at Windscale No. 1 Pile on 10th October 1957, Her Majesty's Stationery Office, London.
57. D. E. Clark, Association of Irradiation with Cancer of the Thyroid in Children and Adolescents, *J. Am. Med. Assoc.* 159, 1007-1009 (1955).
58. L. K. Bustad, C. M. Barnes, L. A. George, Jr., K. E. Herde, H. A. Kornberg, S. Marks, and D. E. Warner, Hanford Atomic Energy Works Report HW-38757 (1955).
59. W. B. Looney, R. J. Hasterlik, A. M. Brues, and E. Skirmont, A Clinical Investigation of the Chronic Effects of Radium Salts Administered Therapeutically (1915-1931), *Am. J. Roentgenol.* 73, 1006-1037 (January-June 1955).
60. W. G. Cahan, H. Q. Woodard, N. L. Higinbotham, and F. W. Stewart, Sarcoma Arising in Irradiated Bone, Report of Eleven Cases, *Cancer* 1, 3-29 (1948).
61. The Hazards to Man of Nuclear and Allied Radiations, British Medical Research Council, Her Majesty's Stationery Office, London (June 1956).
62. E. B. Lewis, Leukemia and Ionizing Radiation, *Science* 125, No. 3255, 965-972 (1957).

63. W. M. Court Brown and J. D. Abbat, The Incidence of Leukemia in Ankylosing Spondylitis Treated with X Rays, *Lancet* 268, 1283-1285 (1955).
64. F. W. Spiers, The Hazards to Man of Nuclear and Allied Radiations, Her Majesty's Stationery Office, London (June 1956).
65. R. A. Dudley and R. D. Evans, Radiation Dose to Man from Natural Sources, Hearings before the Special Subcommittee on Radiation of the Joint Committee on Atomic Energy, Congress of the United States, Eighty-Fifth Congress, First Session on The Nature of Radioactive Fallout and Its Effects on Man, June 4-7, 1957. Part 2, pp. 1236-1241.
66. A. M. Brues, Radiation as a Carcinogenic Agent, *Radiation Research* 3, No. 3, 272-280 (November 1955).
67. A. M. Brues, Commentary on the Modes of Radiation Injury, International Conference on the Peaceful Uses of Atomic Energy (June 23, 1955).
68. A. M. Brues, Biological Hazards and Toxicity of Radioactive Isotopes, *J. Clin. Invest.* 28, 1286-1296 (1949).
69. J. C. Aub, R. D. Evans, L. H. Hempelmann, and H. S. Martland, The Late Effects of Internally-Deposited Radioactive Materials in Man, *Medicine* 31, No. 3, 221-329 (1952).
70. W. B. Looney, Late Effects (Twenty-Five to Forty Years) of the Early Medical and Industrial Use of Radioactive Materials. Their Relation to the More Accurate Establishment of Maximum Permissible Amounts of Radioactive Elements in the Body. Part II. *J. Bone and Joint Surg.* 38-A, No. 1, 175-218 (January 1956).
71. B. Glass, The Genetic Hazards of Nuclear Radiations, *Science* 126, No. 3267, 241-246 (1957).
72. J. L. Kulp, W. R. Eckelmann, and A. R. Schulert, Strontium-90 in Man, *Science* 125, No. 3254, 934 (1957).
73. Pathologic Effects of Atomic Radiation, *Natl. Acad. Sci. Natl. Research Council, Publ.* 452, (1956).
74. R. E. Lapp, Strontium-90 in Man, *Science* 125, No. 3254, 933-934 (1957).
75. W. O. Caster, Strontium-90 Hazard: Relationship between Maximum Permissible Concentration and Population Mean, *Science* 125, No. 3261, 1291 (1957).
76. M. Eisenbud, Hearings before the Special Subcommittee on Radiation of the Joint Committee on Atomic Energy, Congress of the United States, Eighty-Fifth Congress, First Session on The Nature of Radioactive Fallout and Its Effects on Man, May 27-29 and June 3, 1957. Part 1, pp. 554-591.
77. Maximum Permissible Amounts of Radioisotopes in the Human Body and Maximum Permissible Concentrations in Air and Water, *Natl. Bur. Standards Handbook (U. S.)* 52 (1953).

DISCUSSION OF METEOROLOGICAL FACTORS AND FALLOUT DISTRIBUTION*

Lester Machta

Weather Bureau, U. S. Department of Commerce, Washington, D. C.

1 INTRODUCTION

It is typical of nuclear tests that the radioactivity of the fission products has been released to the atmosphere. The deposition of these fission products on the earth's surface is loosely termed "fallout." The total quantity of fallout depends primarily on the total fission yield of the nuclear device, but the area in which the deposition occurs depends on a number of features, such as the atmospheric winds, the yield of the bomb, the terrain, and altitude of the explosion. It is the purpose of this discussion to review the atmospheric processes that transport the radioactive debris back to the ground.

Fallout is assigned to three classes:¹ first, local or close-in, which is deposited within the first 24 hr after the detonation; second, intermediate or tropospheric, which is deposited largely within the first 30 to 60 days; and finally, delayed or stratospheric, which can take many years to be deposited.

2 LOCAL FALLOUT

The main feature that distinguishes local fallout from other categories is its appreciable settling speed. The particles are large and heavy enough to fall through the air. As the particles settle, they are transported by the winds. Particles originating at different altitudes are acted upon by differing winds, causing fallout in different areas. If the winds blow in approximately the same direction at all altitudes, as frequently occurs, the pattern is long and narrow. This gives rise to the familiar cigar-shaped pattern, with the larger particles, or those originating at lower levels, falling closer to the burst point. If, on the other hand, there is appreciable change of the wind direction with altitude, then the patterns may be very broad and may show no similarity to a cigar.² If the winds are extremely light, the particles will settle back to earth close to ground zero and will make for very intense nearby radioactive areas. If the speeds are comparatively strong, the same particles will be carried to greater distances and will become diluted by being spread over larger areas with lower radiation intensities. Further, from day to day one finds that the wind direction changes, varying the general direction of the fallout area.

The meteorological principles governing the prediction of local fallout are well known.² Although there is considerable uncertainty in the prediction of the winds, this is not the only uncertainty in predicting dosages on the ground. One must also associate a known amount of radioactivity with each particle size at every altitude in the nuclear cloud. It is impossible to obtain this radiological data from first principles based on the thermodynamics of the fireball and the chemical and physical properties of the entrained debris. Instead, one uses observed

* Paper presented at Symposium on Low-Level Irradiation, American Association for the Advancement of Science, Indianapolis, Indiana, Dec. 30, 1957.

deposition patterns to reconstruct the initial radioactivity of the particles in the nuclear cloud by using winds to assign a point on the ground to a given particle size and altitude of origin. There is a considerable body of local fallout information for the relatively low-yield explosions that occur in the Nevada Test Site, and predicting dosages in the unpopulated areas adjacent to the Nevada Test Site is reasonably competent. There is appreciably less fallout information for high-yield explosions in the Pacific, and one cannot be sure that the particle size distribution will be similar for bombs exploded over large cities as for the Pacific coast or the Nevada desert.

On the positive side the meteorologist can provide certain information about local fallout. First, he can tell the area in which there may be some radioactivity based on the winds and crude knowledge of the explosion characteristics. Second, he can tell the approximate time of arrival of local fallout; therefore, for civil defense applications, warning to the down-wind population is possible.

The Federal Civil Defense Administration (FCDA) has prepared a hypothetical bombing attack on the U. S., using some 2500 Mt of fallout in the form of 250 bomb drops. The picture for FCDA Operation Sentinel, which was shown publicly for the first time at the congressional hearings on fallout,² illustrates the fallout pattern as it would appear 24 hr after this widespread bombing, using Nov. 20, 1956, winds (Fig. 1). The code in the lower left-hand corner of the figure indicates the dosages in the fallout pattern. It is quite evident that there is very little area east of the Mississippi Valley free of fallout. Secondly, I should like to make it clear that some of the uncontaminated areas in the western part of the country would be covered with fallout if another set of winds or ground zeros were used.

The main purpose for including Fig. 1 is to put any remarks on test fallout in perspective. Nuclear tests provide milliroentgens of radioactivity in populated regions³ in comparison with tens, hundreds, or thousands of roentgens to be found during a nuclear war.

3 INTERMEDIATE FALLOUT

Fallout particles come in a continuous spectrum of sizes. It is believed that fallout that occurs more than a few days after an explosion consists of particles with negligible settling speeds. Probably the bulk of the fallout that occurs during the period from 1 to about 60 days originates in the troposphere, even for explosions whose clouds go into the stratosphere. The justification for saying that most of the intermediate fallout is deposited within 30 to 60 days is shown in Fig. 2. The ordinate shows the amount of radioactivity measured by air filtration in the lower atmosphere on a logarithmic scale plotted against time in weeks. The concentration decreases rapidly in time with a half time of about 20 days for Nevada tests whose nuclear clouds do not enter the stratosphere. It can be seen that the delayed fallout from the megaton or thermonuclear tests do not show this rapid decrease with time.

It has been known for many years that the prevailing winds blow west to east or in few instances, east to west. Thus, transport in a north-south direction is much slower than in a west-east direction. This results in a fallout band,⁴ which lies almost entirely near the latitude of the source. Figure 3 shows this for a Nevada test series in the spring of 1953. Intermediate or tropospheric fallout from tests conducted in the Pacific Proving Grounds is similarly distributed in a band around latitude 11°N.

The technique for sampling fallout by using gummed film collectors is quite uncertain, but, if it is accepted as correct, then 25 per cent of all the fission products in a test appears as intermediate fallout for Nevada tests.¹ The fraction of the fission products deposited in intermediate fallout from Pacific tests is even less well known because of the vast unsampled ocean areas in the tropics, but the fraction is considerably smaller than 25 per cent.¹

In terms of evaluating hazard from intermediate fallout, two points should be noted: first, although all the nonlocal fallout fission products formed in kiloton-sized explosions contribute to intermediate fallout, the amount produced by such an explosion is very small compared to that of a high-yield explosion. Thus, 500 nominal (20 kt) bombs provide the same amount of fission products, roughly speaking, as one 10-Mt fission bomb. On the other hand, the deposition per unit area is clearly higher in those regions in which tropospheric fallout occurs than would be the case if the radioactivity were distributed uniformly over the entire globe. Thus, the average concentration at latitude 40°N in Fig. 3 is about five times higher than would

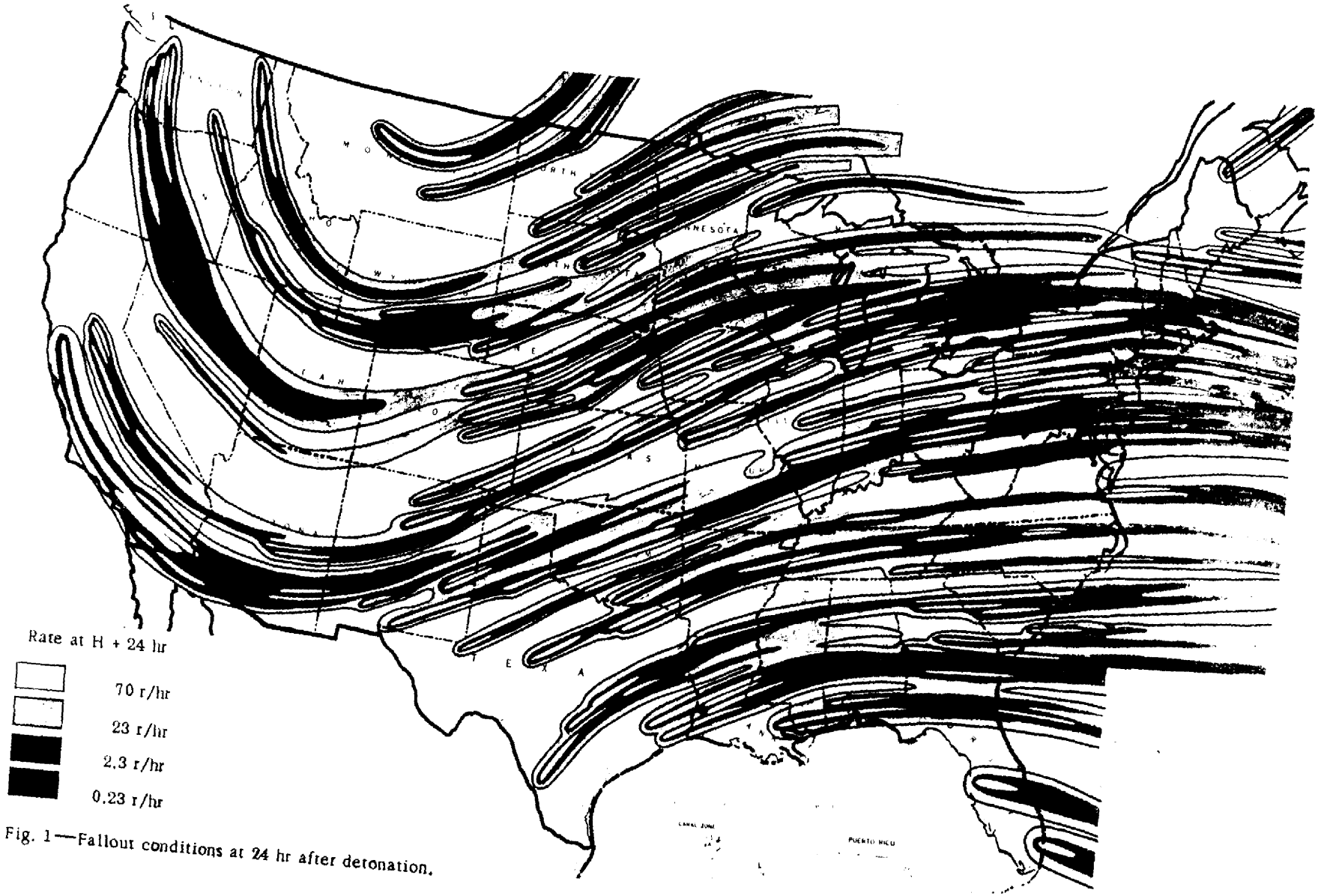

Fig. 1—Fallout conditions at 24 hr after detonation.

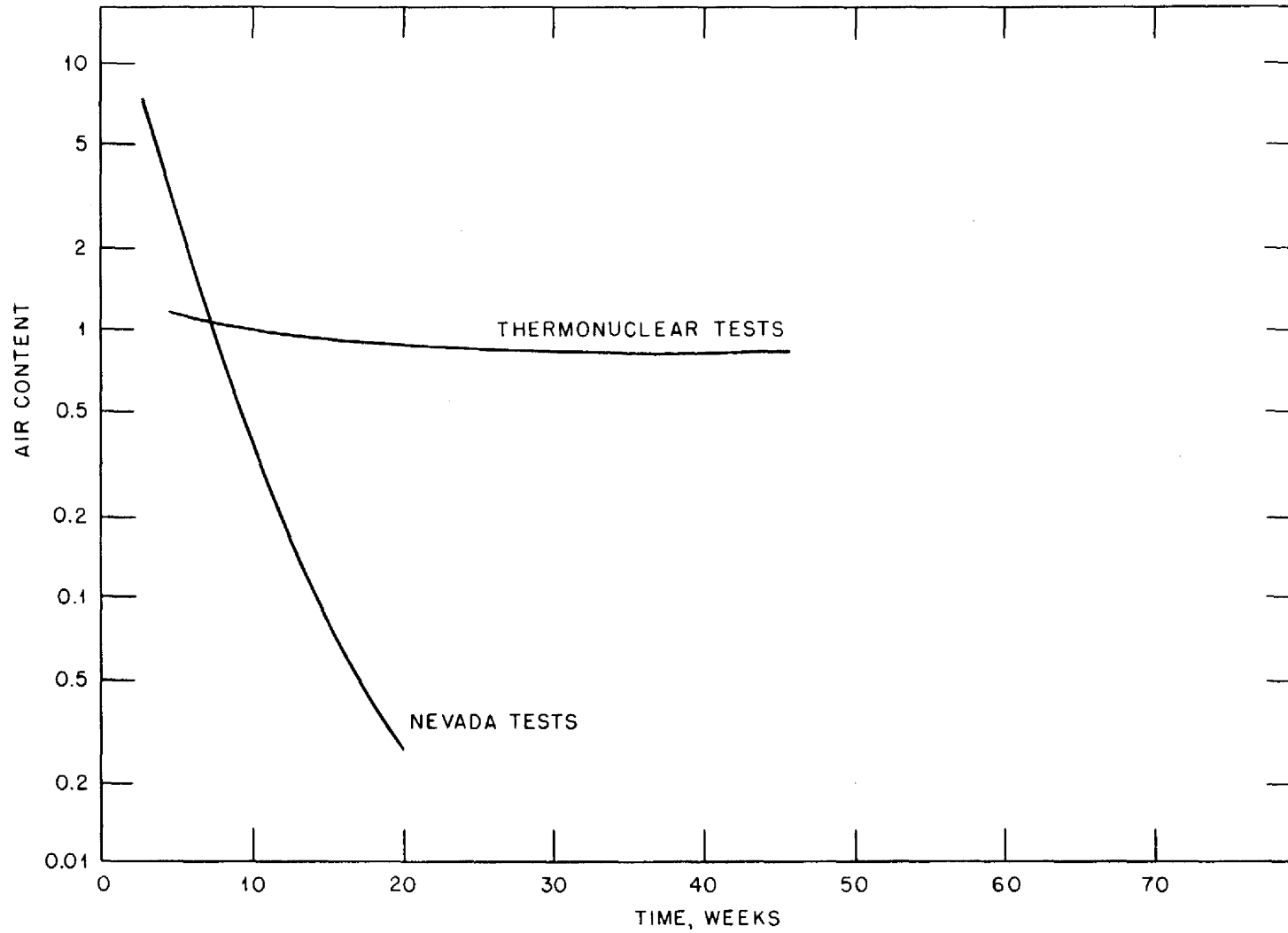

Fig. 2—Intermediate fallout from Nevada and thermonuclear tests.

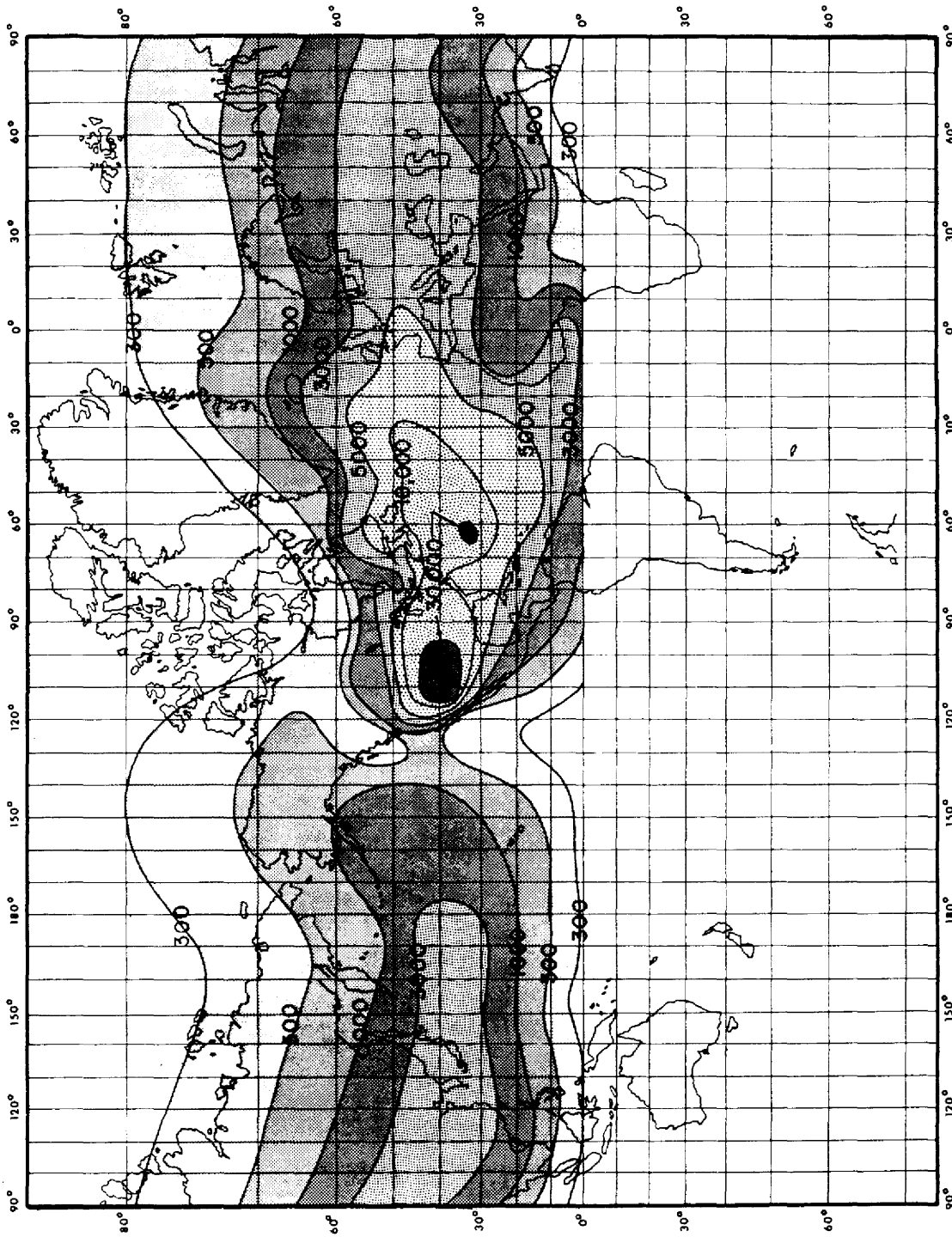

Fig. 3 — Intermediate fallout from Operation Upshot-Knothole.

be the case if the deposition were uniform over the entire globe.

Within the band of tropospheric fallout there is patchiness as well. Not only is there a general decrease downwind and in a north or south direction from the source but also variations which depend on rainfall. Thus outside of the first, say, 600 miles from Nevada Test Site, one does not find the highest individual deposition immediately beyond 600 miles but rather in the Albany-Troy region of New York State about 2000 miles away. Here, a rapidly moving nuclear cloud at 40,000 ft was scavenged by an intense thunderstorm. The probability of a second such coincidence in the same place is, of course, very small.

We find that precipitation scavenging is the main mechanism for the deposition of small particles. The ratio of deposition in rain to that in nonrain varies from 2 to 20.

Rapid deposition in a matter of 30 to 60 days of intermediate fallout allows some of the shorter-lived isotopes to contribute to the hazard, whereas the delayed fallout, taking years to come down, involves potential hazard from only those fission products whose half lives are of the order of years. It is also worthwhile to note that the intermediate fallout is all deposited, whereas much of the delayed fallout still, literally, hangs over our heads.

4 DELAYED FALLOUT

Delayed fallout is of interest because it represents widespread deposition of a very sizeable amount of the fission products. In megaton explosion it contributes about 15 to 20 per cent for land shots and over 95 per cent for air bursts of the total fission yield. This fallout originates exclusively from particles that were initially injected into the stratosphere.

Perhaps a word of explanation about the use of the terms troposphere and stratosphere is in order. In 1899 Teisserenc de Bort first flew a balloon to high altitudes. His ascent probably looked like that on the left-hand side of Fig. 4. The temperature first decreased with altitude and then abruptly remained constant or increased with height. The point of discontinuity in the

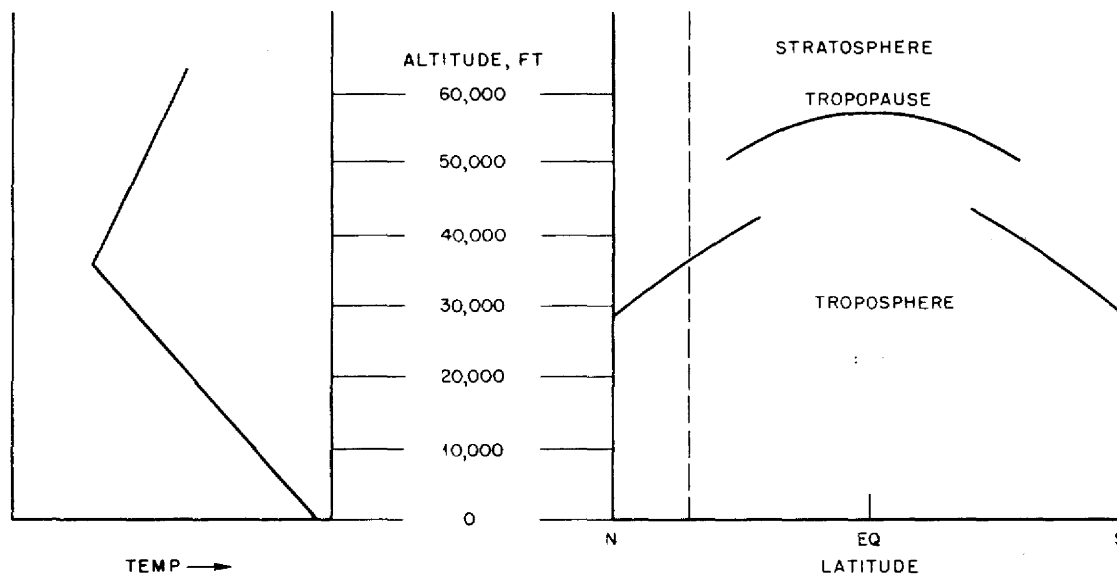

Figure 4

vertical temperature gradient is now called the tropopause and separates the troposphere below from the stratosphere above. Many of you have seen smoke emitted from a stack on a windy afternoon. It clearly reflects the turbulent nature of the atmosphere for the case of temperature decreasing with height, typical of the troposphere. On the other hand, you have also seen smoke during quieter, nonsunny periods (evenings, for example), when, near the ground, the temperature increases with height. This nonturbulent evening-like condition, we think, typifies the stratosphere. We are fairly sure that a pollutant near the ground will mix throughout the vertical extent of the troposphere in a matter of days with a few exceptions. It is suspected that the vertical mixing of the stratosphere is very much slower, being similar to the near-laminar evening mixing. Contrary to the views of some nonmeteorologists, the prolonged

suspension of contaminants in the stratosphere is due to the slowness of vertical mixing throughout the lower stratosphere and not because the tropopause is some kind of a semi-permeable barrier.

The right-hand side of Fig. 4 shows the change of the tropopause height with latitude. It is highest in the equatorial region, lowest in the polar regions, and, on many occasions, shows a break in the temperate latitudes coinciding with the jet stream (a rapid west to east river of air in the upper troposphere). Less is known about the stratosphere than the troposphere, mainly because it is harder to get at. Certain evidence of atmospheric motions on transport phenomena in the stratosphere which bear on the question should be reviewed. Where should the stratospheric radioactive particles reenter the troposphere? The residence time in the stratosphere is also of concern, but, since our interest revolves around Sr^{90} or Cs^{137} , both with 28-year half lives, no significant decay will occur in the stratosphere if the residence time is much less than 28 years—which appears to be the case.

5 ATMOSPHERIC TRACERS

For more than eight years, the British have been making measurements of humidity by specially instrumented aircraft to about 48,000 ft or about 13,000 ft into the stratosphere.⁵ These flights show, as seen on the left-hand side in Fig. 5, a frost point as low as 190° absolute over England. They find that this low value is amazingly constant in time. A flight in the stratosphere from the Sahara Desert to Iceland confirmed the same constant low frost point.

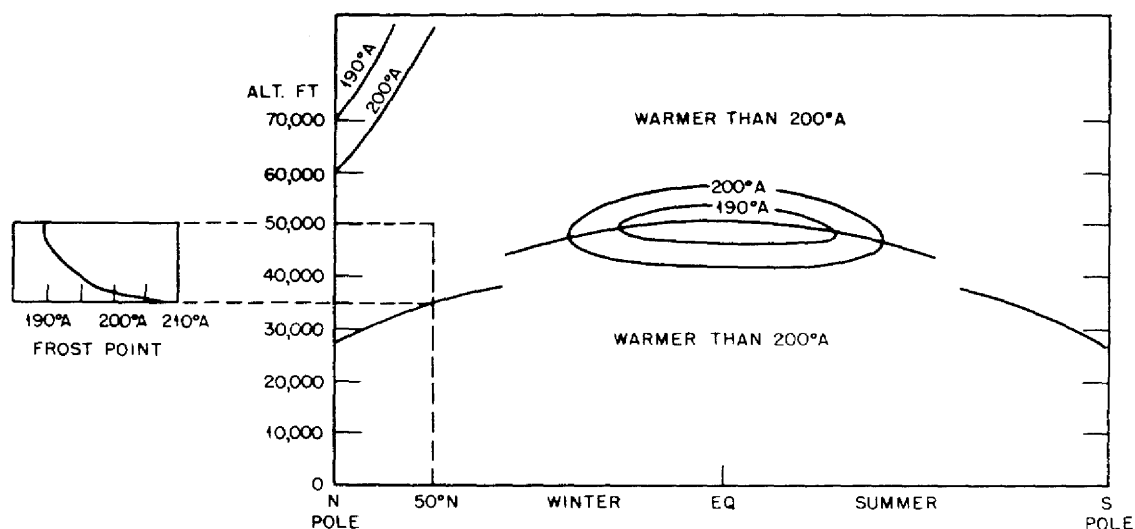

Figure 5

Where could air originate that has a frost point as cold as 190° absolute? To attain this low value, the air must have passed through a region with temperatures this cold in order to condense out the excess moisture. The most likely place, as can be seen from the right-hand side of Fig. 5 is the upper troposphere or lower stratosphere of the equatorial region. This probably means that stratospheric air over England at, say, 45,000 ft came from the equatorial tropopause region. It also means that very little tropospheric air was probably transported upward over England since this would bring moisture with it and would raise the humidity values above that which is observed.

A second tracer of atmospheric motions is ozone. Ozone is formed by photochemical reactions at about 75,000 ft and above. It is transported into the lower stratosphere by mixing and direct air movement, so that most observations below 75,000 ft show more ozone than should be there from photochemical processes alone. Measurements made primarily in Germany and reported by Paetzold⁶ (Fig. 6) and as yet unreported work of Brewer and colleagues in England reflect the same seasonal variation in ozone between the tropopause at about 75,000 ft. Between 60,000 and 75,000 ft there is an ozone maximum in late winter and a minimum in late summer. In the 30,000- to 45,000-ft layer, as well as in the troposphere, the

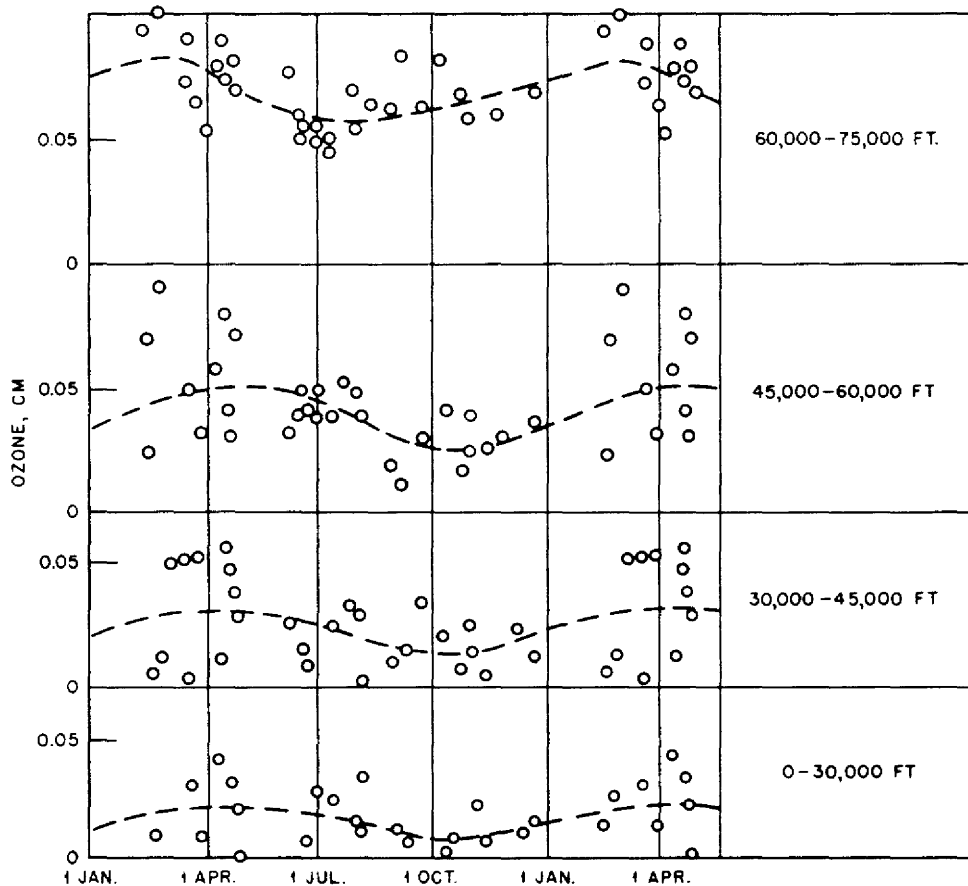

Fig. 6—Ozone, Weisenau, Germany.

maximum is in the spring and minimum in autumn. Many meteorologists ascribe the winter and spring maximum mainly to sinking motion. Thus ozone measurements can be interpreted as follows: the stratosphere of the temperate and probably the polar latitudes contain an ozone maximum in the winter or spring due to sinking motions in the winter; this ozone then empties into the troposphere; therefore by the early autumn there is a minimum.

The final bit of evidence that provides a clue to air motions is the short- and long-wave radiation balance in the stratosphere.⁷ It is well known that there is a net heating in the troposphere in the equatorial regions, whereas the polar regions have a deficit. This drives our atmospheric engine. The exact mechanism by which the exchange of heat occurs is not completely known. A certain amount is exchanged by mixing processes, but some is probably carried by direct circulation in which there is equatorward flow near the ground and poleward flow aloft. Firm evidence for this cell is limited to the tropical trade winds. Since the same areas are heated and cooled in both the troposphere and stratosphere, the stratosphere may participate in this cell. In such a picture, all of the equatorward motion takes place in the lower troposphere, but a small part of the circulation may move poleward in the lower stratosphere. If this is so, there should also be a seasonal variation in the poleward stratospheric circulation since the radiation balance data indicate that the greatest net loss of heat occurs during the polar winter.

The picture based on humidity, ozone, and heat budget is summarized by Fig. 7. This particular version was taken from a paper by Dr. N. G. Stewart and his colleagues of the U. K.⁸ and shows, as Brewer argues, that the air leaves the stratosphere only in the temperate or polar regions. (Reference 8 is included in Part 4 of this report as the second paper.) Those of us who propose this picture readily admit that the actual state of affairs is undoubtedly much more complex than shown here and that some mixing is superimposed on the direct circulation.

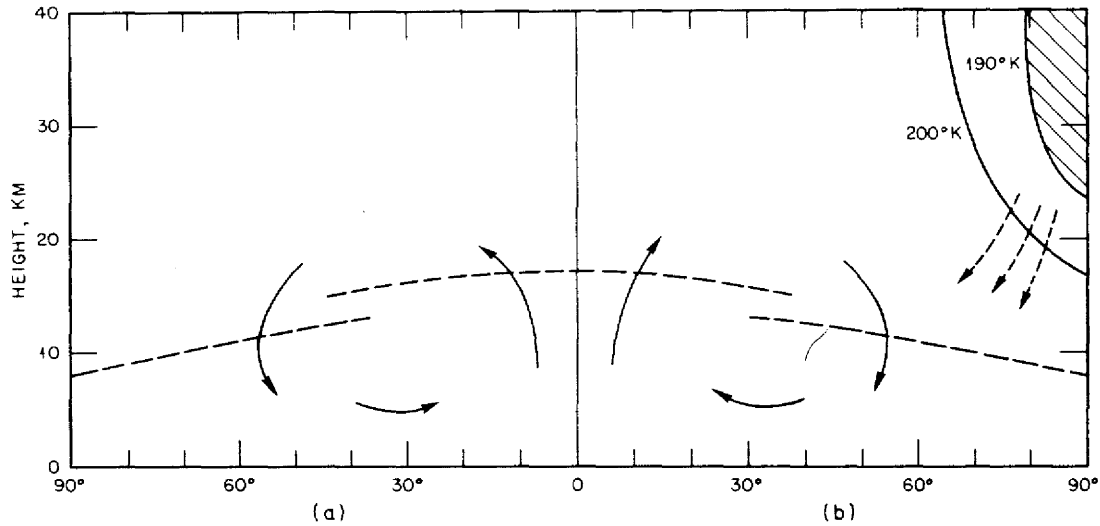

Fig. 7 — Atmospheric circulation model (after Dobson and Brewer). a. Summer. b. Winter.

6 OBJECTIONS

There are two serious objections to this model: First, air that rises into the stratosphere must undergo a marked heating. This can be shown on the left side in Fig. 8. If a parcel of dry air rises and expands without gain or loss of heat from its surroundings, temperature will cool along the dashed line called the "dry adiabat." When it rises 1 km or 3200 ft, it will have cooled owing to expansion by 10°C. The solid curve shows the observed stratospheric temperature increase with altitude in equatorial stations. This observed picture is exceedingly persistent day after day. The rising parcel must gain heat presumably by short-wave solar and long-wave terrestrial radiation to bring the parcel's temperature back along the dotted curve to the observed curve. Two objections to this process may be noted: (1) If the rising motion is

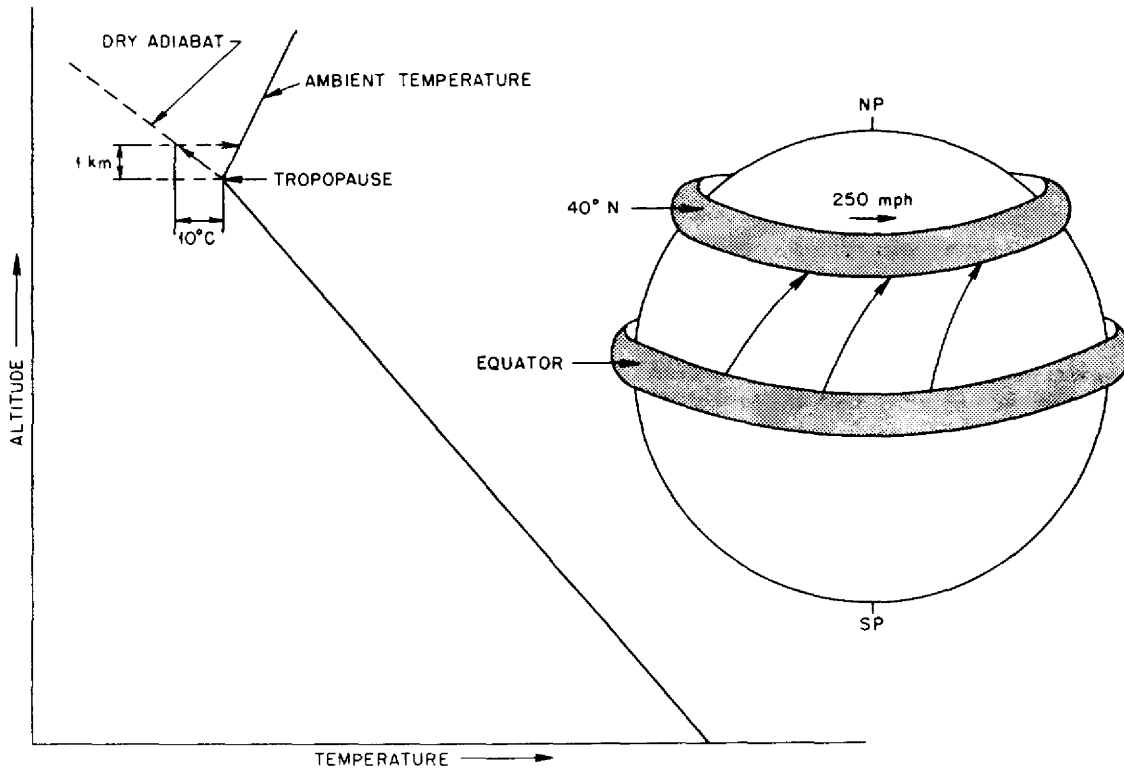

Figure 8

as fast as 1 cm/sec or a half-mile per day, which is roughly what I believe necessary, then a heating of 10°C per day is needed. Present theory calls for warming of only two or three degrees centigrade per day. Second, it does seem fortuitous, but not impossible, that two diverse atmospheric processes, cooling by expansion and radiational heating should produce as good a daily balance.

A second objection is a dynamic one and is shown on the right-hand side of Fig. 8. A ring of air at the equator will, if transported poleward, maintain its absolute angular momentum. Thus, if there were no west or east wind at the equator, this ring when brought to, say 40° would rotate at a speed corresponding to a 250-mph west to east wind. These tremendous speeds are rarely if ever observed. If there is a poleward circulation, there must also be some mixing to dilute the high resulting winds. Thus not all meteorological reasoning favors the circulation model.

Let us summarize the predictions that Fig. 7 offers for the problem of the motion of stratospheric radioactive particles: the large amount of debris that originates in the Pacific Proving Grounds will be carried poleward and then be subjected to descending motion. This subsidence has its peak value in the winter and spring. As air is brought to the lower stratosphere, certain processes in the tropopause region can then carry it into the troposphere. Ordinary downward movement through the tropopause may be helped by several other special processes in the temperate and polar latitudes. The air that enters the troposphere brings radioactive particles. These are then removed from the atmosphere in a short time in much the same way as the intermediate fallout is removed. Stratospheric debris from USSR tests should, by this picture, remain in the temperate latitude, or move even further poleward, but in any case it should have a shorter stratospheric residence time. The model does not predict whether there should be greater deposition of delayed fallout in temperate or polar latitudes. Climatological statistics on precipitation would dictate more fallout in the rainier temperate latitudes, other things being equal.

7 THE OBSERVED FALLOUT

It is now proposed to compare this meteorological model with the observed distribution of fallout. Figure 9 shows a meridional cross section in which the Sr^{90} deposition per unit area in soil is plotted on a linear scale as the ordinate and sine of the latitude as the abscissa.^{4a} The data show a marked peak in the temperate latitudes of the Northern Hemisphere, a minimum in the equatorial region, and a secondary and uncertain maximum in the temperate latitudes of the Southern Hemisphere. It also shows great variability among samples collected at the same latitude. Part of the variability is due to the difficulties in the analysis of the soil samples, and part is due to meteorological conditions such as raininess. Soil analyses provide the cumulative fallout since the beginning of the atomic era. Figure 10 shows the fallout in rain during a given year, 1956, by some 11 stations in the U. K.⁸ and two stations in the U. S. rainfall network.⁹ Again the ordinate is millicuries of Sr^{90} per unit area on a linear scale, but the abscissa is latitude on a linear scale. The same general distribution is evident. Everyone agrees that the data show more Sr^{90} deposition in temperate latitudes of the Northern Hemisphere than elsewhere in the world—a picture that would be used to recommend the reality of our meteorological model if it were not for one fact. The Sr^{90} comes not only from the stratospheric deposition but also from tropospheric fallout from the smaller tests in Nevada and in the USSR test areas, both of which are located in the temperate or polar latitudes. The critical question is: "What part of the nonuniformity is from stratospheric fallout?" Fortunately, fission-product analysis is able to shed some light on this question. Both rain water and air filters have been analyzed for shorter-lived fission products as well as the long-lived Sr^{90} . The contribution of the Sr^{90} from tropospheric fallout may therefore be assessed by finding the age of the Sr^{90} . If it can be shown that the age of the fallout is appreciably greater than 30 to 60 days, then it is very unlikely that much of the Sr^{90} could have originated from tropospheric fallout, irrespective of whether there was a recent atomic test. Several short-lived fission products, such as Sr^{89} , Ce^{141} (references 8, 10, and 11) and others, as well as dating by gross fission-product decay,⁸ indicate average ages greatly in excess of 60 days. This evidence suggests that most of the fallout in the temperate latitudes must have been stratospheric fallout. The conclusion is further supported by estimates of the amount of tropospheric fallout from

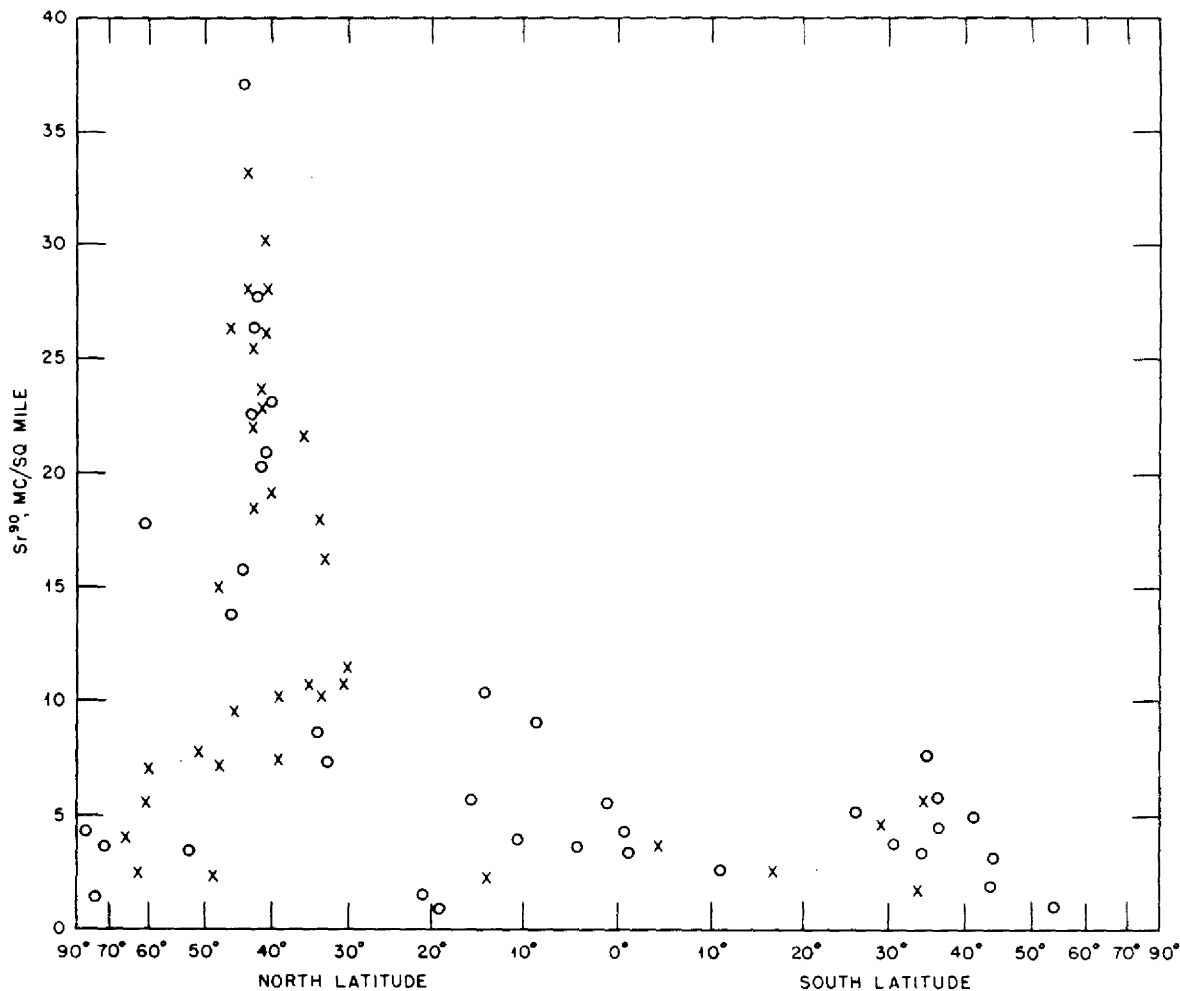

Fig. 9— Soil data, 1956: ○, electroanalysis × 1.15; x, HCl extraction.

Nevada and USSR tests. Their estimated contribution amounts to a very small part of the temperate latitude bump shown by the data.⁴ Other less certain arguments all add up to the same picture: the bulk of the long-lived fallout in the temperate latitudes appears to have come from the stratosphere. However, the main evidence—age determination by short-lived fission products—suffers from possible defects due to fractionation and errors in radiochemistry. New measurements are being taken of the stratospheric Sr⁹⁰ distribution and other, and perhaps more certain, short-lived fission products to further check whether delayed fallout is uniform, or as proposed here, nonuniform over the globe. From existing evidence, it can be argued that, even if the intermediate fallout were subtracted, there would be little doubt that a marked peak of the stratospheric fallout in the temperate latitudes of the Northern Hemisphere would still appear. The polar region may show smaller values due to the smaller amount of precipitation or to the main injection into the troposphere entering the temperate rather than polar regions.

A second prediction of the meteorology calls for a seasonal variation in the Sr⁹⁰ removal from the stratosphere with a peak in the late winter or spring. Although Fig. 11 shows the plot of 45-day fallout amounts for Milford Haven, England, in rain⁸ (the solid line), similar results are found for all of the U. S. stations^{9,12} that sample rain water and air concentration. The British were also able to sample and interpret air concentration of bomb radioactivity in the lower stratosphere for a short time in 1954 and 1955, the results being shown by the heavy dots. The left-hand ordinate is the concentration of Sr⁹⁰ per unit volume of rain water rather than deposition per unit area. A plot of deposition per unit area shows just about the same picture, indicating that the seasonal variation in deposition is not due to the fact that it rains

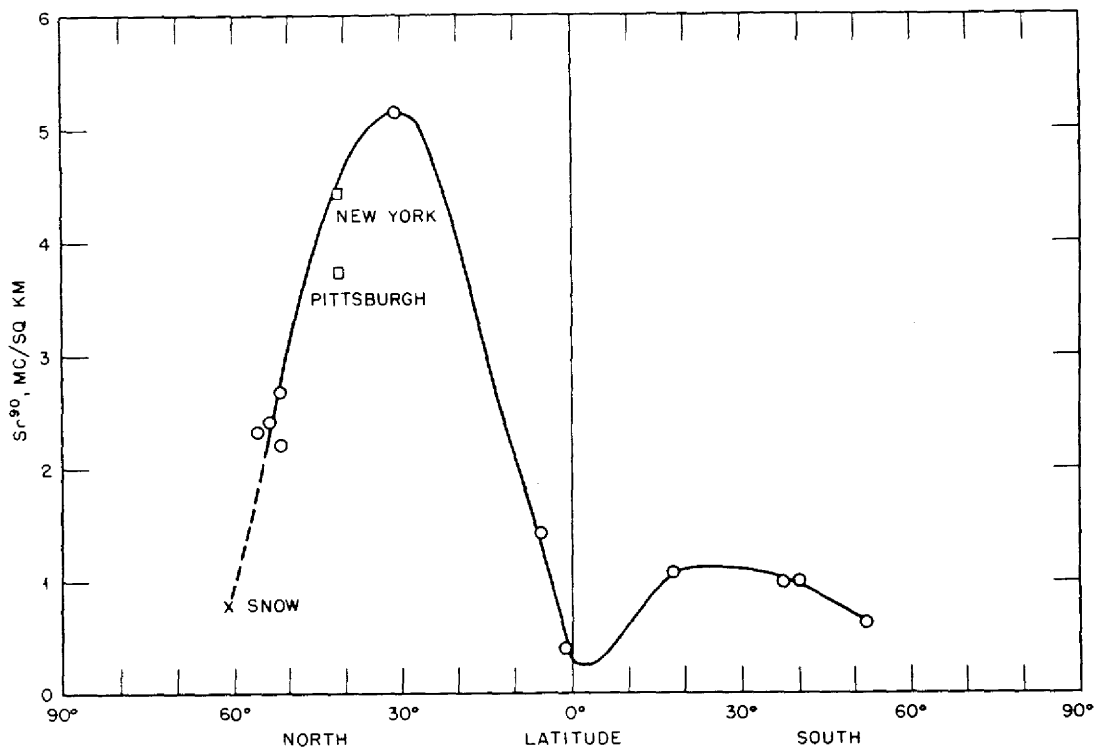

Fig. 10— Total deposition of Sr⁹⁰ in 1956 at various latitudes.

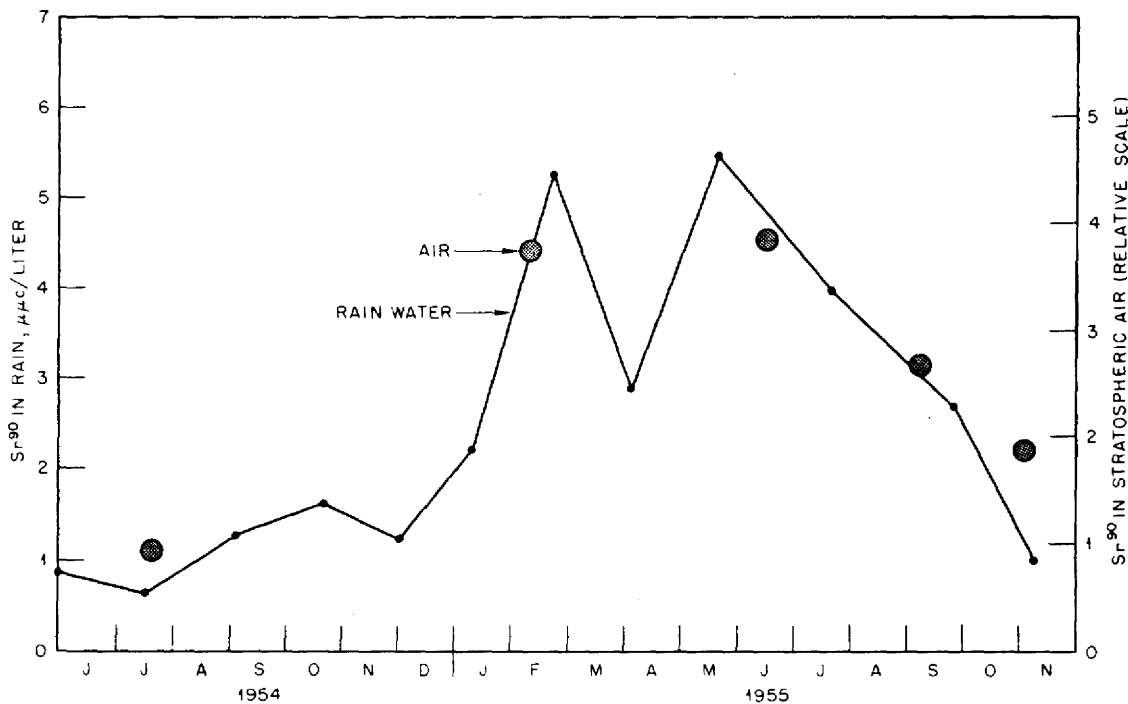

Fig. 11— Correlation between Sr⁹⁰ concentrations in rain water and in the lower stratosphere.

more in the springtime. Figure 11 shows, in the broad view, a maximum in spring and a minimum in the autumn and is supported, more or less, for each year since 1955. The stratosphere is in phase with the deposition trends.

Figure 12 shows further seasonal variations⁸ at Milford Haven, England, but adds Ohakea, New Zealand, at 40°S. Note that the peak and valley in the Southern Hemisphere station occurs during its spring and fall also, but with only a small amplitude. The Southern Hemisphere fallout is mainly that small fraction from the U. S. Pacific tests which mixed into the Southern Hemisphere stratosphere.

In addition to differences in fallout due to large-scale air motions just described, there are also variations due to anomalies in precipitation amounts. There is a large body of evidence that indicates that the Sr⁹⁰ deposition is proportional to the amount of precipitation in a given area. Average annual precipitation plotted against cumulative deposition in soil up to about 1955 for selected sites¹² is shown in Fig. 13. The solid curve for stations in the eastern Mediterranean area shows most clearly the dependence of fallout on the amount of rainfall. The figure also shows that the greater precipitation in South America deposits less fallout, undoubtedly because the air concentration is lower.

Fallout of Sr⁹⁰ in the United States in late 1956, as obtained from soil samples,⁹ is shown in Fig. 14. The higher fallout values in the northern tier of states, relative to the southern tier, has already received considerable publicity and is not new. Among the possible explanations are errors in the soil collection or analyses. Soil analyses apparently suffer from such serious difficulties that one is led to be suspicious of results that might not follow some reasonable pattern. But these data do reflect a pattern, with perhaps the exception of the 7 mc/sq mile at Grand Junction. Further, from March through July 1956, the New York Operations Office of the AEC analyzed rain water from many stations over the U. S.¹³ The results also fell into a pattern (Fig. 15) for July 1956. It is clear that stations north of 40°N yield more Sr⁹⁰ fallout per unit of precipitation than stations to the south of 40°N. This puzzling difference in U. S. fallout is now a subject of research.

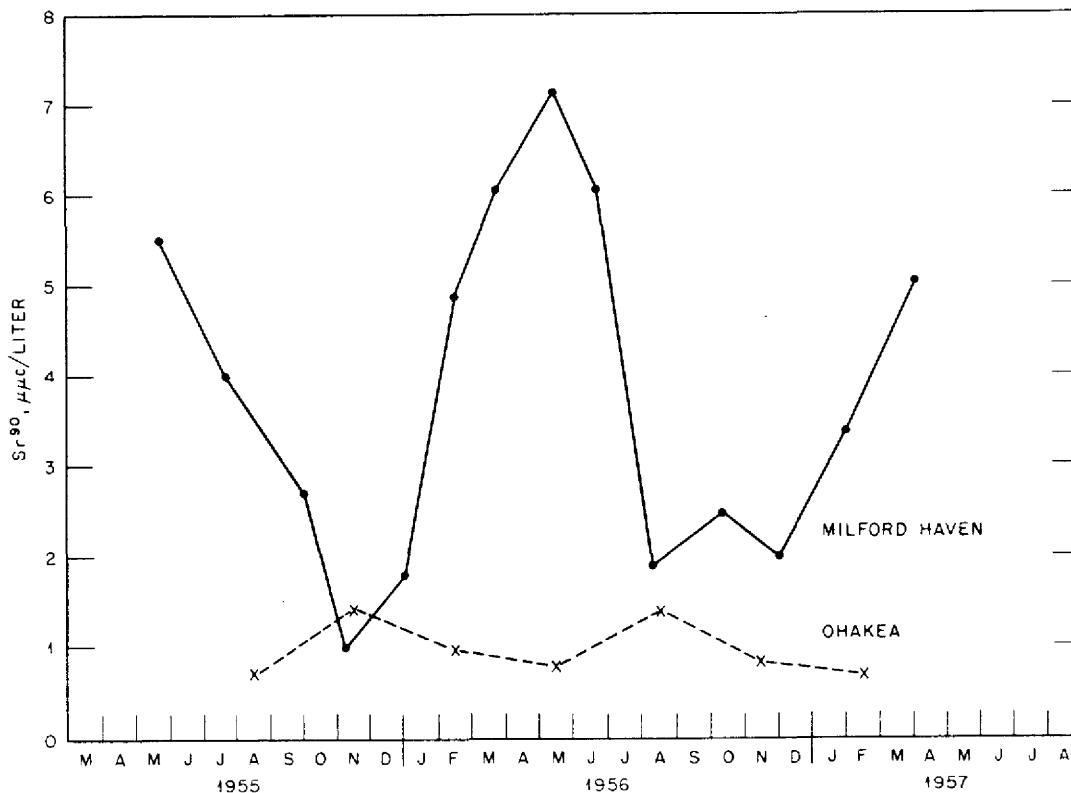

Fig. 12—Seasonal variation of Sr⁹⁰ content in rain water at Milford Haven, England, and Ohakea.

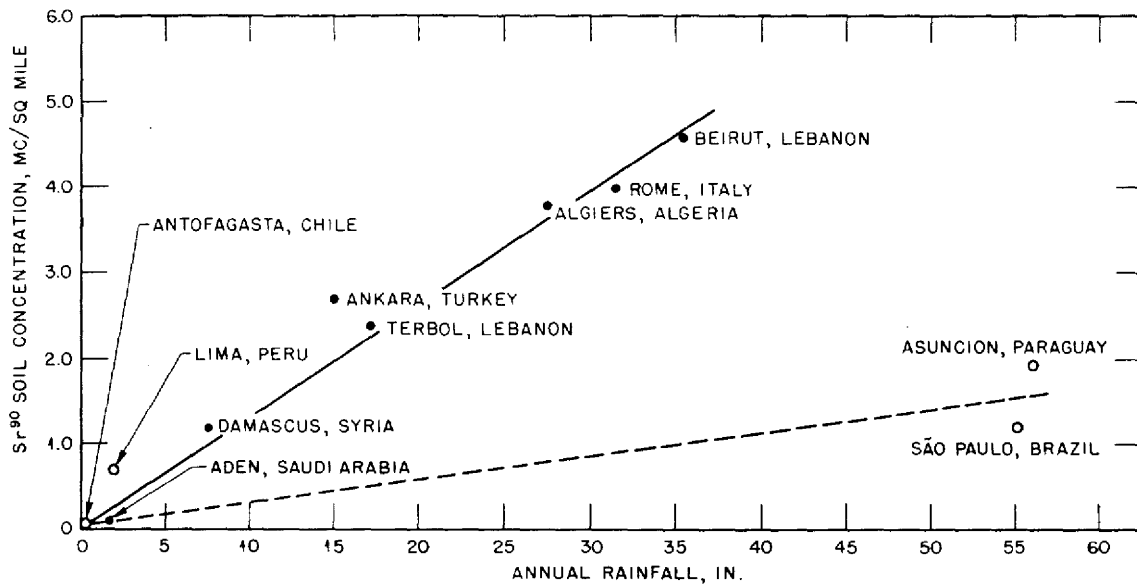

Fig. 13— Sr^{90} soil concentration vs. annual rainfall. —, Eastern Mediterranean area, February 1955; ----, South America, January 1956.

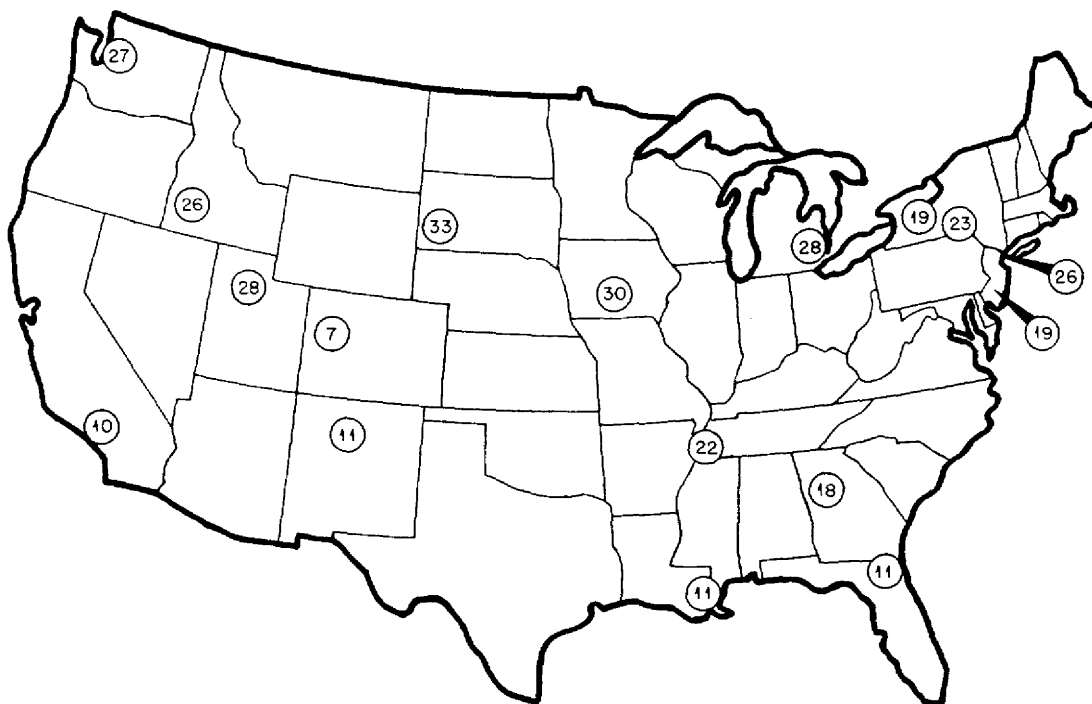

Fig. 14— Sr^{90} in U. S. soil (HASL, Oct. 8, 1956) (HCl extraction method). Numbers are in millicuries per square mile at individual site.

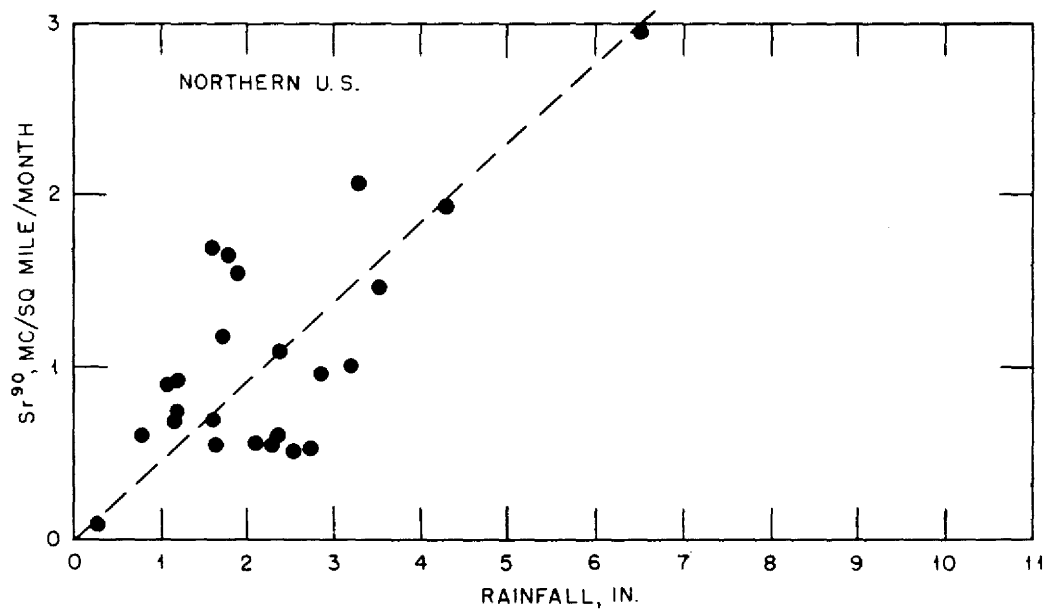
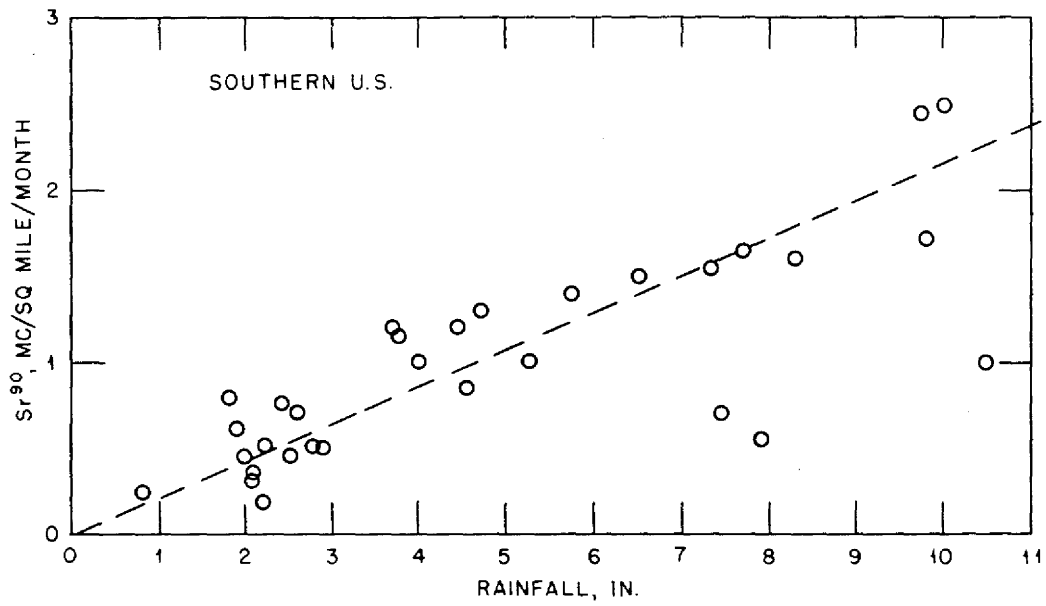

Figure 15

8 CONCLUSIONS

It is thus evident that meteorological theory is involved in predicting future fallout. Such forecasts are uncertain not only because of ignorance about future testing but also because we can only guess at where the fallout will be deposited. The model described in this paper is, after all, still being developed. However, although meteorological deficiencies might appear to be large, they are smaller than the biological uncertainties described in other papers of this symposium.

REFERENCES

1. Lester Machta, Meteorological Factors Affecting Spread of Radioactivity from Nuclear Bombs, *J. Wash. Acad. Sci.* 47(6): 169-179 (June 1957).
2. W. W. Kellogg, in *The Nature of Radioactive Fallout and Its Effect on Man*. Washington: U. S. Government Printing Office, 1957. pp. 104-118 (Testimony before the Special Subcommittee on Radiation of the Joint Committee on Atomic Energy, 85th Congress, 1st Session, 1957.)
3. M. Eisenbud, in *The Nature of Radioactive Fallout and Its Effect on Man*. Washington: U. S. Government Printing Office, 1957. pp. 574 and 575 (Testimony before the Special Subcommittee on Radiation of the Joint Committee on Atomic Energy, 85th Congress, 1st Session, 1957.)
4. L. Machta, in *The Nature of Radioactive Fallout and Its Effect on Man*. Washington: U. S. Government Printing Office, 1957. pp. 141-161 (Testimony before the Special Subcommittee on Radiation of the Joint Committee on Atomic Energy, 85th Congress, 1st Session, 1957.)
- 4a. Modified by data from unpublished USAEC Reports, New York Operations Office.
5. G. M. B. Dobson, Origin and Distribution of the Polyatomic Molecules in the Atmosphere, *Proc. Roy. Soc. (London), A*, 236(1205): 187-192 (1957).
6. H. K. Paetzold, New Experimental and Theoretical Investigations on Atmospheric Ozone Layer, *J. Atmospheric and Terrest. Phys.* 5: 128-140 (1955).
7. G. Ohring, The Radiation Budget of the Stratosphere, Scientific Report No. 1, Project No. 429, Contract No. AF19(604)-1739, New York University, June 1957.
8. N. G. Stewart et al., The World-Wide Deposition of Long-Lived Fission Products from Nuclear Test Explosions, Report AERE-MP/R-2354, October 1957. (This report is included in Part 4 as the second paper.)
9. W. F. Libby, in *The Nature of Radioactive Fallout and Its Effect on Man*. Washington: U. S. Government Printing Office, 1957. pp. 611-616 (Testimony before the Special Subcommittee on Radiation of the Joint Committee on Atomic Energy, 85th Congress, 1st Session, 1957.)
10. New York Operations Office, AEC (unpublished).
11. Naval Research Laboratory (unpublished). L. B. Lockhart, in *The Nature of Radioactive Fallout and Its Effect on Man*. Washington: U. S. Government Printing Office, 1957. pp. 650-652 (Testimony before the Special Subcommittee on Radiation of the Joint Committee on Atomic Energy, 85th Congress, 1st Session, 1957.)
12. E. A. Martell, in *The Nature of Radioactive Fallout and Its Effect on Man*. Washington: U. S. Government Printing Office, 1957. pp. 616-650 (Testimony before the Special Subcommittee on Radiation of the Joint Committee on Atomic Energy, 85th Congress, 1st Session, 1957.)
13. W. R. Collins, Jr., and N. A. Hallden, A Study of Fallout in Rainfall Collections from March through July 1956, USAEC Report NYO-4889, Apr. 30, 1957 (unclassified).

THIS PAGE
WAS
INTENTIONALLY
LEFT BLANK
IN
ORIGINAL

METEOROLOGICAL INTERPRETATION OF Sr⁹⁰ FALLOUT*

L. Machta and R. J. List

Weather Bureau, U. S. Department of Commerce, Washington, D. C.

In Lausanne, Switzerland, on Mar. 27, 1958, Dr. W. F. Libby of the USAEC presented some new information on physical aspects of the world-wide fallout problem and provided an interpretation of these data. It is the purpose of this paper to use this same information and provide a meteorological interpretation of the findings. It must be admitted, as Dr. Libby pointed out in his talk, that there is still room for differences and personal interpretation.

1 BACKGROUND

It is a matter of observation, as will be shown later, that Sr⁹⁰ fallout is nonuniform over the globe. It apparently possesses two types of variations: the first is due to rainfall differences and proximity to proving grounds and the second is a large scale nonuniformity. This latter is characterized by much more fallout in the temperate latitudes of the Northern Hemisphere than elsewhere. The question at issue is the cause of the higher fallout in temperate latitude observations. Dr. Libby's argument is that the bump in the fallout profile in our latitudes is almost entirely due to tropospheric fallout—fallout which occurs within a month or two from tests conducted within the latitude band of the bump. Steward et al., Machta, and others have argued that the contribution of tropospheric fallout from tests in Nevada and in the U.S.S.R. falls far short of accounting for the temperate latitude bump. They also have claimed that radiochemical analysis suggests that the "age" of the fallout is too great to make most of the temperate latitude fallout tropospheric. However, it has been pointed out that fractionation of the fission products and difficulties in the radiochemistry of the radioisotopes could conceivably make these conclusions misleading. The AEC is currently obtaining "age" determinations from Ba¹⁴⁰ which, it is hoped, will permit a less ambiguous evaluation of the source of fallout in the temperate latitudes. This paper will continue the argument that the stratospheric component of fallout is markedly nonuniform.

2 OBSERVED FALLOUT

The observed fallout patterns to be shown refer exclusively to Sr⁹⁰ results unless otherwise noted. This fission product, as has been repeatedly indicated, represents the radionuclide with the greatest potential world-wide hazard from nuclear testing. It is produced in large quantities having about a 5 per cent fission yield, and a 28-year half life. Physically, it is in a particulate form, but the size of particles that have had an appreciable stratospheric residence time have never been measured. Rather, it is surmised that they must be small enough to remain airborne for years and must therefore be about 0.1 μ or smaller in diameter.

Three types of routine and extensive sampling are in progress at ground levels. These are (1) soil analysis, (2) rainwater analysis, and (3) air concentration measurements. Soil

* Presented at a Public Meeting sponsored by the Washington Chapter, Federation of American Scientists, May 1, 1958, on Radiation and its Effects, Washington, D. C.

analysis provides the cumulative deposition up to the time the soil has been collected. Rain water sampling provides a current record of how much Sr^{90} has been deposited in a given time interval. The rain water (funnel, pot, or tub) technique assumes that practically all the Sr^{90} comes down in precipitation, a fact that seems to be fairly well established or, perhaps more accurately, that a pot really collects about the same amount as is deposited on the soil. Finally, the use of air filtration techniques also provides a record of current rather than cumulative amounts of Sr^{90} . It is also obvious that the air concentration is not necessarily a good measure of the amount of Sr^{90} that is being deposited out. There are suggestions that the removal of Sr^{90} particles by natural precipitation is more effective at the altitudes at which the natural clouds occur than at the ground level.

3 SOIL

Figure 1 shows the latest available results of soil sampling in various parts of the globe in 1956. The points have been taken in both Americas, Europe, Asia, Australia, and Africa, mainly

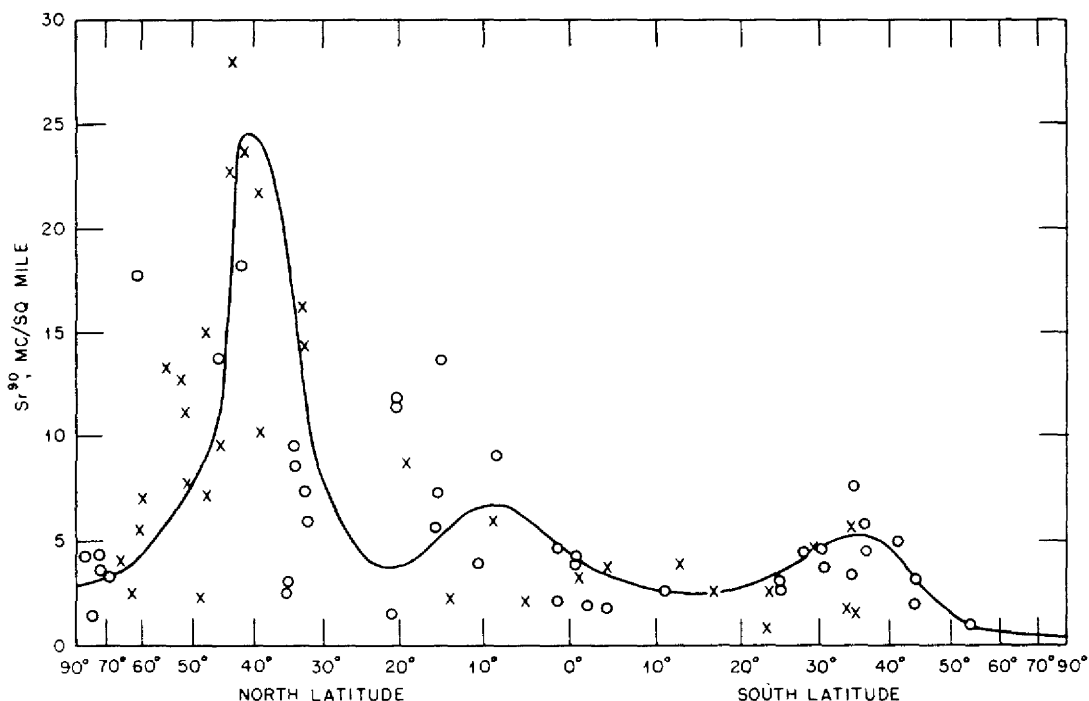

Fig. 1 — Soil data, 1956: O, electroanalysis $\times 1.15$; x, HCl extraction.

by Dr. Alexander of the Department of Agriculture. The electroanalysis technique apparently does not extract all the radiostrontium out of the soil. Comparison with HCl extraction shows a large variability in ratio of the results of the two techniques, but an average increase of about 50 per cent is suggested for the electroanalysis as noted on the figure. It is apparent that a large scatter of points exists at any one latitude. The main reason for this scatter is probably the real differences in fallout due to precipitation differences and other meteorological factors. Secondary reasons are the errors in the extraction of the strontium from the soil and counting of the radioactivity. (Other causes such as run-off of water in heavy rain, penetration of depths below the 2 in. sampled, etc., are undoubtedly present but are probably small compared to the first two classes of errors.) The heavy line is an attempt to construct a single north-south average profile.

Dr. Libby has provided estimates of the amount of tropospheric fallout of Sr^{90} from all tests. Table 1 shows this estimate of the number of megatons equivalent Sr^{90} fallout from the U.S.S.R., U. S. (Nevada), U. S. (Pacific), U. K. (Pacific), and U. K. (Australia) tests. The lower part of Fig. 2 shows a north-south profile for the Upshot-Knothole test series in the spring of

Table 1—SOURCES OF RADIOACTIVE FALLOUT TO DECEMBER 1957*

Country	Latitude	Mt
Tropospheric debris		
U.S.S.R.	50°N	1.7
U. S. (Nevada)	37°N	1.0
U. S. (Pacific)	11°N	1.3
U. K. (Pacific)	3°N	1.5
U. K. (Australia)	35°S	0.1
Stratospheric debris		
U. S.		24.8
U.S.S.R.		11.2

* Data from W. F. Libby.

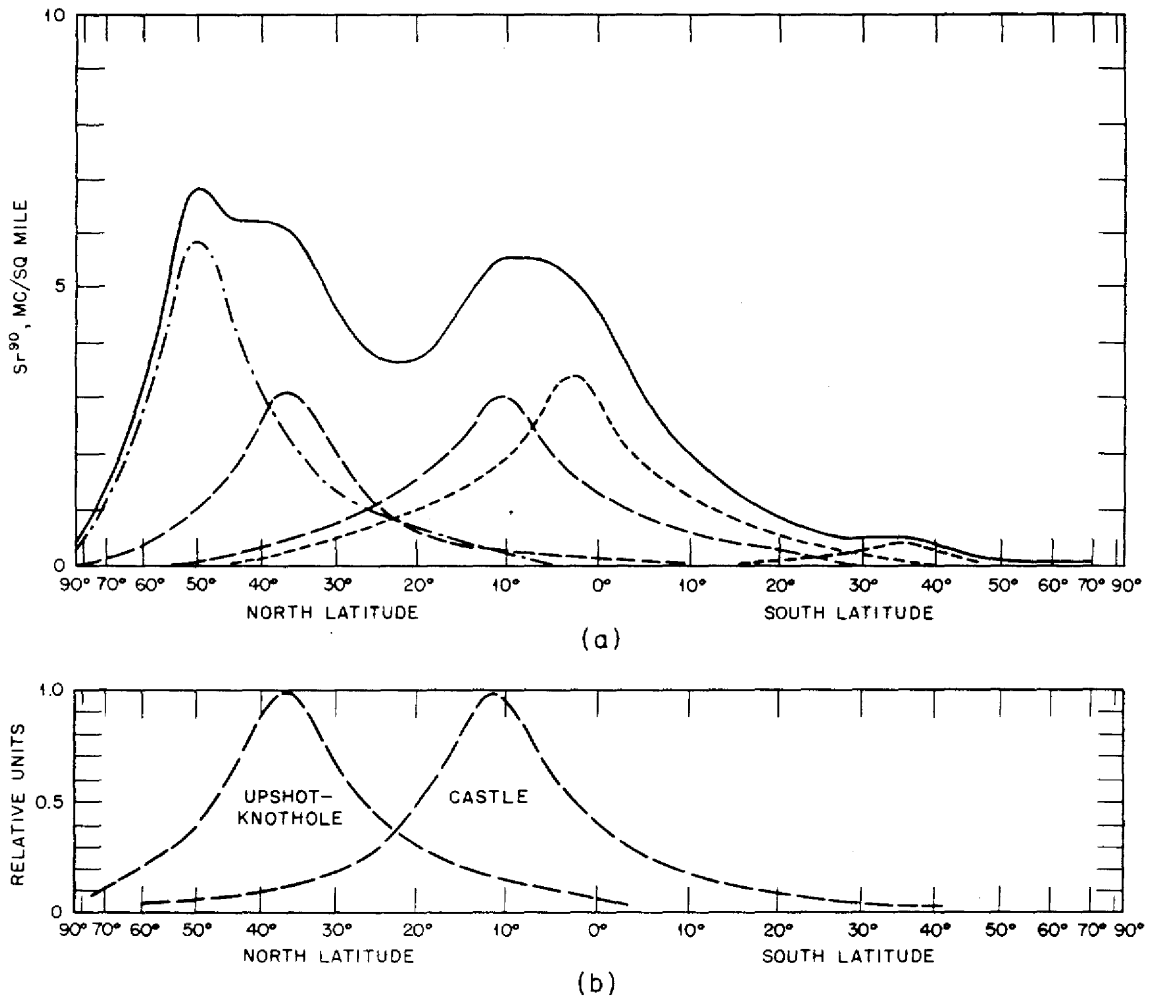

Fig. 2— a. Total tropospheric fallout: --- United States; ----, United Kingdom; - · - · -, USSR.
 b. Observed tropospheric profiles from U. S. tests.

1953 in Nevada centered around 37°N. Essentially, all the fallout that is deposited is tropospheric because the tests in Nevada are rarely powerful enough to throw debris into the stratosphere. The lower part of the same figure shows a pattern around 11°N. This is the fallout that has occurred within the first 30 or so days after the Castle test series at the Pacific

Proving Grounds—probably mostly tropospheric. In both cases, the close-in fallout has been omitted. The upper part of Fig. 2 shows the superposition of all the tropospheric fallout patterns as the heavy line as well as the individual contributions based on the lower curves. The heavy line is now offered as the probable world-wide tropospheric fallout.

In order to find the amount of stratospheric fallout, it now is possible to subtract the cumulative tropospheric fallout curve in the upper part of Fig. 2 from the cumulative total fallout curve of Fig. 1. Unfortunately, the dates for the various sets of data do not coincide. The observed curve contained points for many different times in 1956, and the tropospheric fallout curve has been computed as of the end of 1957. Hence, in Fig. 3, the actual observed curve has been adjusted to the end of 1957, by adding the pot fallout at stations corresponding to the latitudes of the arrows. A certain amount of extrapolation is necessary since not all pot stations were operative from mid-1956 to the end of 1957. Though some error is added by performing this extrapolation to the end of 1957, this is not more than 5 or 10 per cent of the 1956 value at each latitude, in our opinion.

Figure 4 now shows the tropospheric and total curves with the difference curve as the heavy solid line. This difference curve is now considered to be the stratospheric fallout. It shows rather clearly that the stratospheric fallout is pronouncedly nonuniform with a peak in the north temperate latitudes. The errors in this curve stem from three sources: first, the determination of the true fallout profile shown in Fig. 1. It is evident that one has considerable leeway in the details of the construction of the observed fallout curve although it is contended that the peak in the temperate latitude fallout will, in any analysis, be at least twice the world mean. The second error, for which we quoted 5 to 10 per cent is in the conversion of 1956 to December 1957 fallout. And finally, the tropospheric profile determination, which is dominated by the uncertainty in the source strength of an unknown magnitude rather than from the shape of an individual tropospheric fallout profile. It is our view that unless the U.S.S.R. tropospheric fallout has been underestimated by a factor of about 3, the data cannot be reanalyzed to yield anything but a nonuniform stratospheric fallout pattern.

4 RAINFALL

Rainfall data have been collected at many stations in the United States, the United Kingdom, and elsewhere. First of all, the rainfall data confirm the north-south profile in the yearly observed fallout, found from the soil data. The rainfall data also show a seasonal variation in the amount of deposition per unit time for stations in the north temperate latitudes. Figure 5 shows a graph for New York City, the station with the longest continuous record in the United States. The abscissa is time on a linear scale, and the ordinate the amount of fallout per month. It is seen that the fallout is greater in the spring and less in the autumn. One can also see that the heavier fallout in the first half of the year is not associated with heavier rainfall. Until 1957, almost all of the United States tests occurred in the spring of the year, more or less. One could have ascribed the increased spring fallout to tropospheric fallout from these spring tests. It still was difficult to understand the lack of fallout from the U.S.S.R. tests in the fall, but, since information of the tropospheric contribution was lacking, this omission was not unreasonable. However, in the summer and early fall of 1957, a test series was conducted in Nevada, Plumbbob, in which we tried, if anything, to minimize local fallout. This meant that tropospheric fallout should have been at least as great as in previous Nevada tests, if not greater. Despite this, the fall of 1957 showed the same drop in fallout experienced in previous years. Data from other stations confirmed this autumn drop.

It has been the position of Machta and Stewart et al., even prior to the Plumbbob tests, that this seasonal variation was caused by stratospheric air being brought into the troposphere in the late winter and spring. This air would bring with it the high Sr^{90} content of the stratosphere. Measurements of ozone (Fig. 6 in the preceding paper), which has its origin at about 30,000 or 40,000 ft in the stratosphere, show that the ozone in the troposphere also exhibits the same seasonal variation shown by the Sr^{90} . Further, Canadian observations of ground level Be^7 concentrations, as seen in Fig. 6 (this paper), also show the same variation as the Sr^{90} . One can stretch one's imagination to find an alternate explanation for this seasonal variation in the Be^7 , but too the most reasonable explanation is the injection of stratospheric air into the

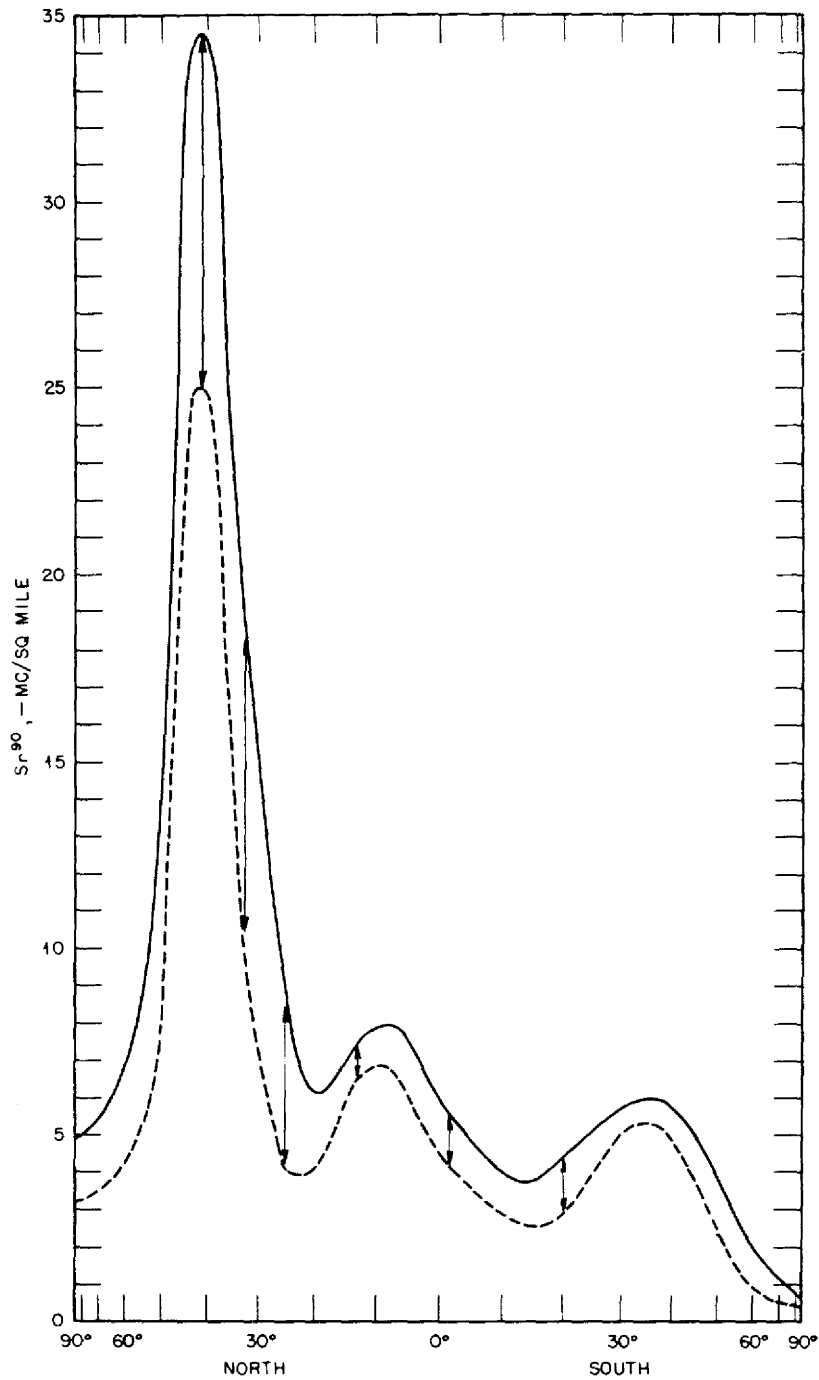

Fig. 3—Adjusted soil data: -----, 1956 soil data; —, data adjusted to December 1957. Vertical arrows show pot data used for adjustment.

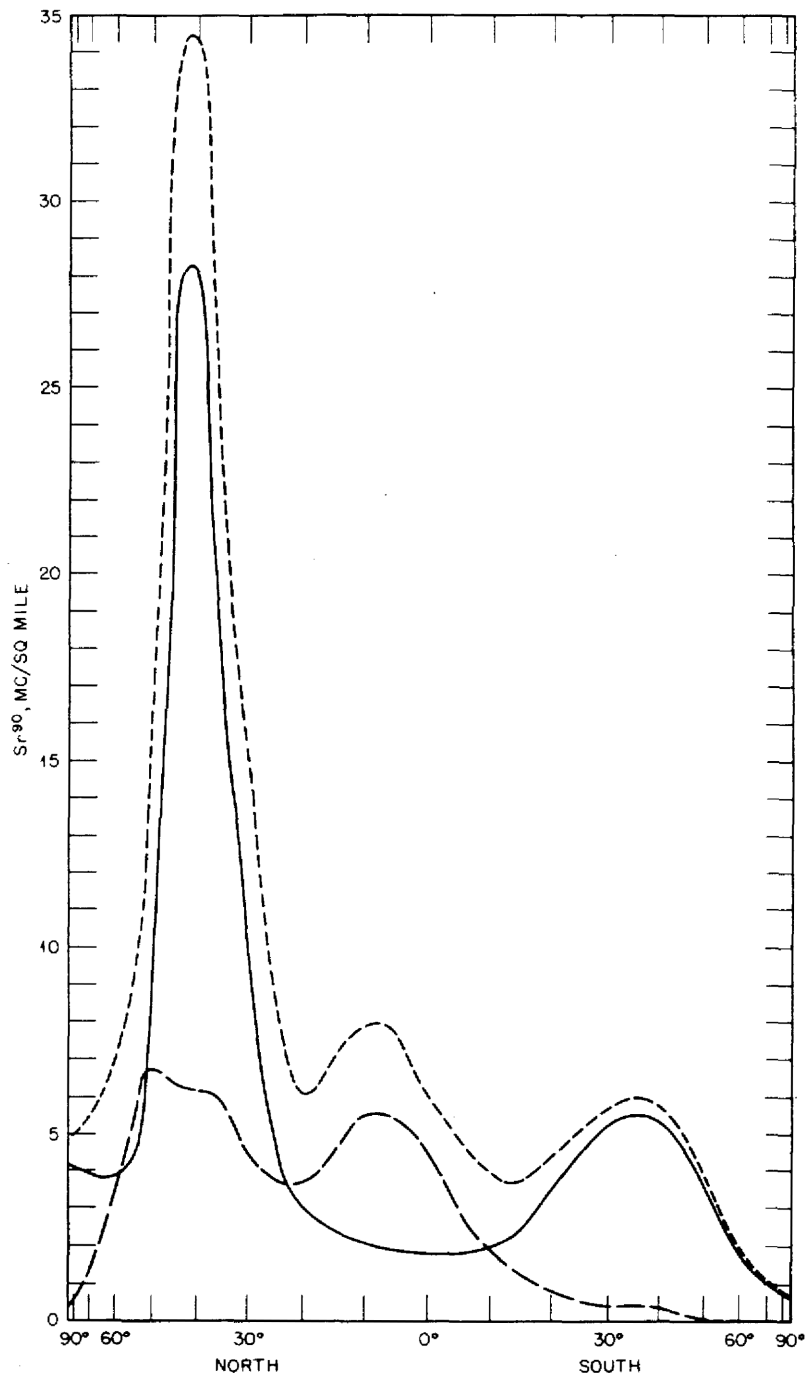

Fig. 4—Soil data: ---, adjusted soil data; - · - ·, tropospheric contributions; —, residual (stratospheric).

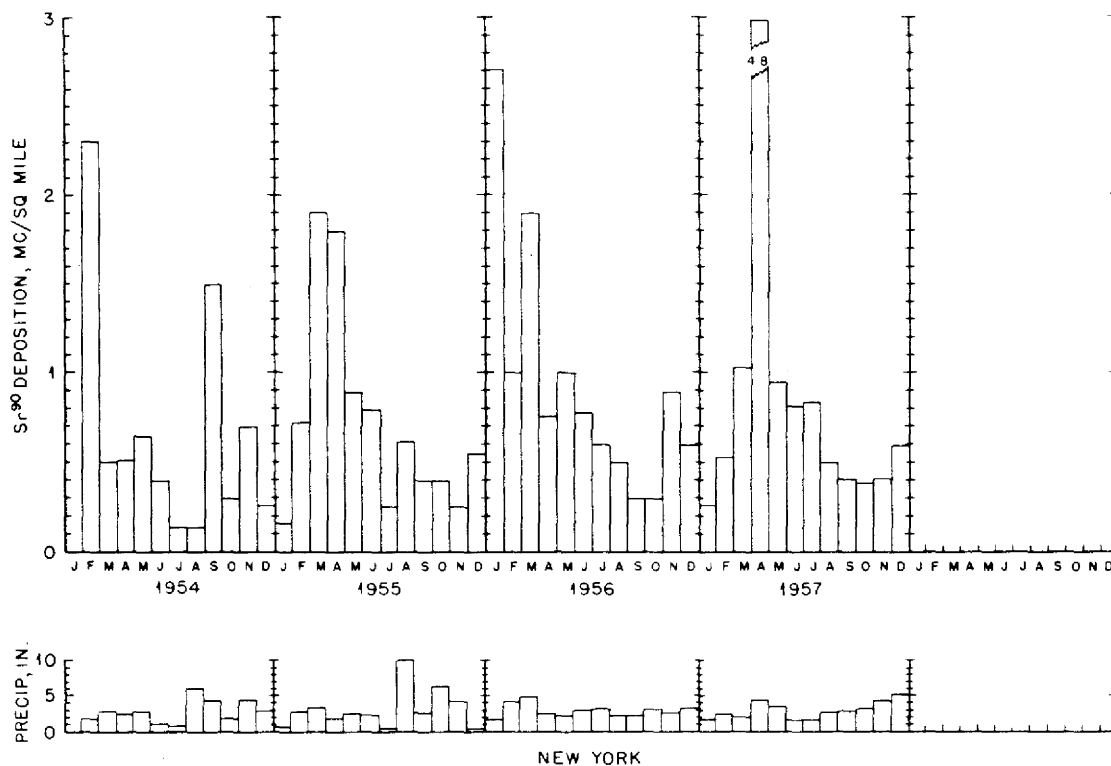

Fig. 5 — Sr⁹⁰ deposition, New York, 1954-1957.

troposphere. It is believed, without much question, that the Be⁷ content of the lower stratosphere is much higher than the troposphere. This is due both to the greater production rate and the absence of precipitation scavenging in the stratosphere.

The meteorological model of exchange between the stratosphere and the troposphere propounded by the authors, Brewer, Dobson, and others, is shown in Fig. 7 in the preceding paper. It indicates that air leaves the stratosphere only in the temperate or polar latitudes and not in the tropical or equatorial latitudes. It is this meteorological picture, with details too technical to treat here, which we feel explains both the peak of stratospheric fallout in the temperate latitudes and a seasonal variation in the fallout rate.

5 RESIDENCE TIME

The hold-up time of Sr⁹⁰ in the stratosphere is also a meteorological problem. Dr. Libby has estimated that the removal is at an exponential rate of about 10 per cent of the stratospheric content coming out each year. The meteorologist objects to the concept of a fixed percentage of the stratospheric content being removed each year; in his view the percentage depends upon the distribution in the stratosphere as well as on the total amount present. The meteorologist is only now ready to begin to treat the stratospheric-tropospheric exchange problem properly. By default, then, the exponential removal rate must be accepted as a first approximation. However, it will be argued that the amount of Sr⁹⁰ removed up to the end of 1957 has been at an average annual rate of 20 per cent or higher rather than 10 per cent.

In Fig. 7 (this paper) the ordinate shows the amount of Sr⁹⁰ in the stratosphere at the time given by the abscissa. The upward jogs are the injections by the United States and U.S.S.R. high-yield tests. The gently sloping straight lines show the decrease in stratospheric content computed at 20 per cent per year. Hence, the ordinate is on a logarithmic scale. In total, some 36 Mt have been added to the stratosphere up to the end of 1957. By the end of 1957, since 23 Mt are left, 13 Mt of the 36 Mt must have been deposited out, if the rate of removal is 20 per cent per year. It was seen in Fig. 5 that our estimate of the amount of stratospheric deposition to the same date was also roughly 13 Mt. Thus this evidence, the

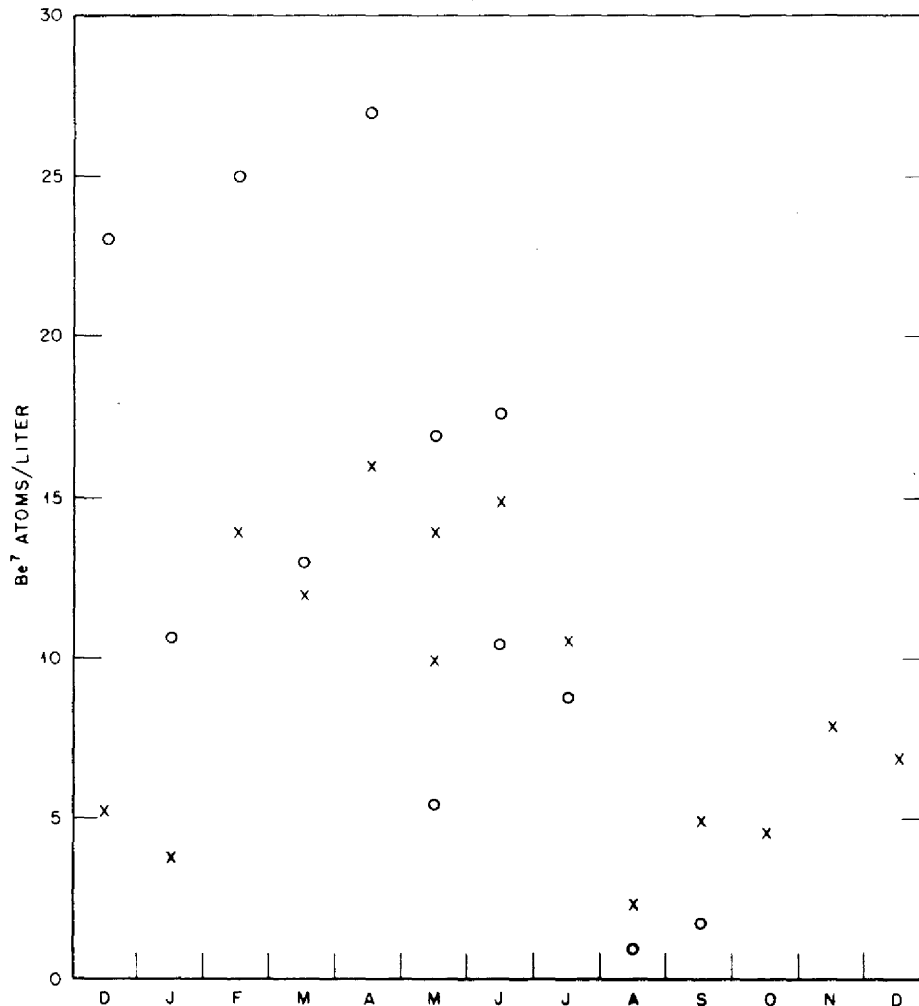

Fig. 6 — Beryllium measurements: O, Station 1; x, Station 2.

best available, suggests that the rate at which the Sr^{90} is leaving the stratosphere is about 20 per cent per year, if the amount of Sr^{90} added to the stratosphere is correct.

Figure 7 also shows that, if the rate were 20 per cent per year, then there should be about 20 Mt left in the stratosphere during the winter of 1956-1957 when a check of the stratospheric content was possible. Figure 8 provides this evidence of the amount of Sr^{90} in the stratosphere in the winter of 1956-1957. The crosses represent the stratospheric air content for stations at the indicated latitudes. The heavy line is the best estimate of the average world-wide content in the same units as the measurements if there were 20 Mt in the stratosphere. The observed stratospheric content is less than found by this prediction. If 10 per cent per year were the removal rate, then there should be about 24 Mt at the same date. This would make the discrepancy worse. Thus, if the data can be trusted, the average rate of removal is greater than about 20 per cent per year. This evidence is admittedly very weak. As yet, the results of the stratospheric sampling program make, in our view, very little sense in either the spatial and temporal distribution or in the fission-product ratios from sample to sample.

In addition, estimates of the stratospheric storage time or removal rate can also be found from the study of C^{14} made by nuclear tests. The evidence supports the thesis that the stratospheric residence time is of the order of years. However, while this study may become a future powerful tool in the study of stratosphere-troposphere exchange, it is difficult to use it quantitatively to determine the removal rate at this time. It is our view, however, that the C^{14} data are, if anything, more consistent with a 20 per cent per year removal rate than a slower rate of, say, 10 per cent per year.

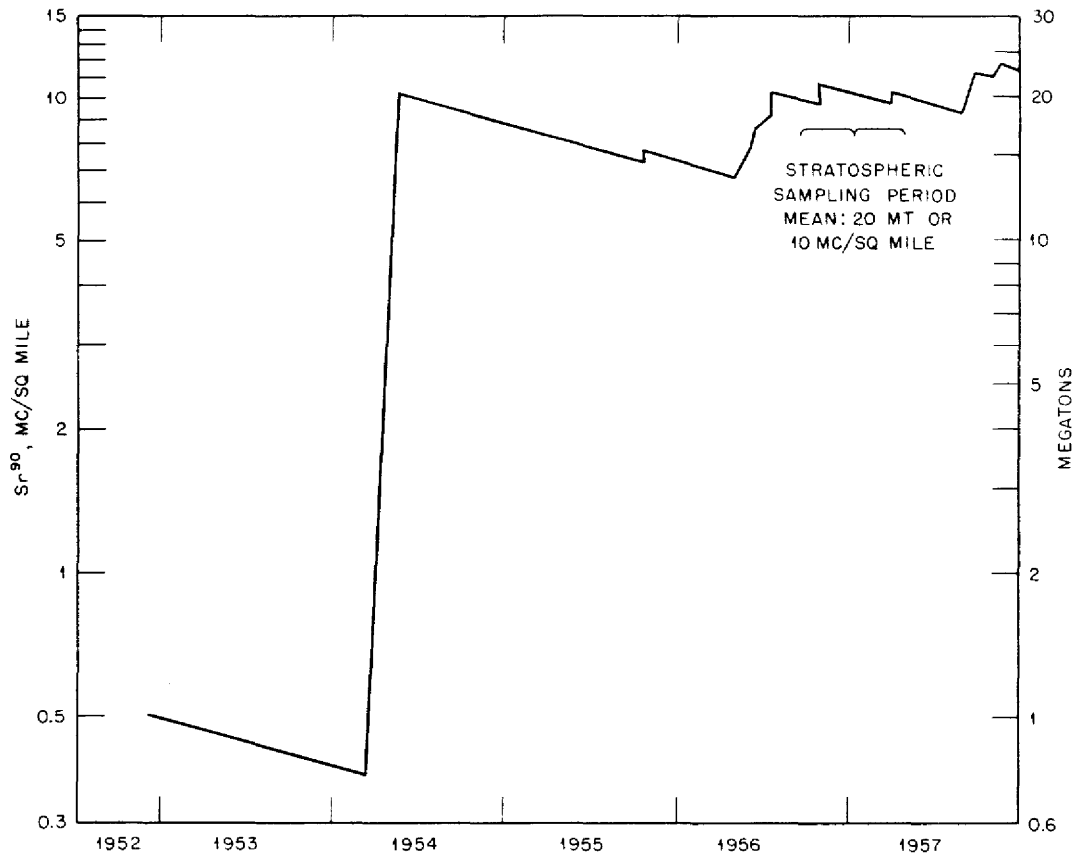

Fig. 7 — Stratospheric inventory.

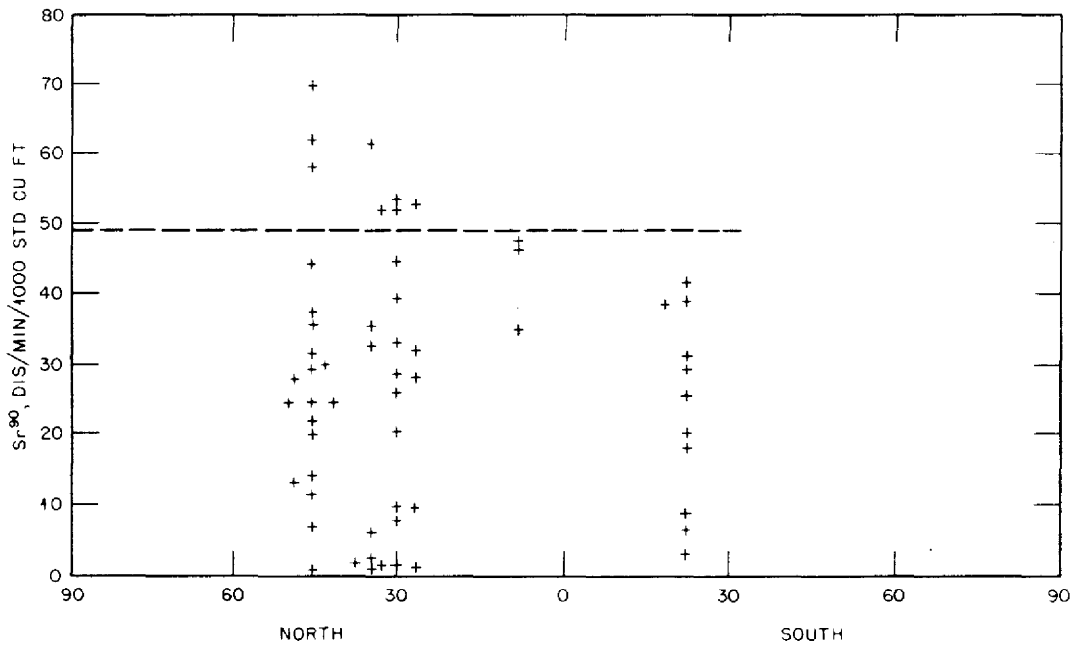

Fig. 8 — Stratospheric Sr^{90} content, Winter, 1956-1957. ----, calculated average value assuming 20 Mt, tropopause at 45,000 ft, and a filter efficiency of 25 per cent.

Although it has been emphasized that the removal rate is 20 per cent per year or more on the average, it should be pointed out even more strongly that we are entirely unsympathetic to the use of a fixed percentage removal independent of the latitude or altitude at which the material is present in the stratosphere. The implication of such a model is that mixing in the stratosphere is very fast and that the hold-up in the stratosphere is due to the difficulty of material in penetrating the tropopause. We are almost positive that there is nothing unique about the tropopause except that it is the bottom of the stratosphere. We are also quite sure that the hold-up in the stratosphere stems from the slow vertical mixing throughout the lower stratosphere in just the same way that smoke emitted from a chimney on quiet nights shows no measurable vertical mixing. We believe that the latitude as well as the altitude of injection will determine the amount of Sr^{90} removed at various times.

6 FUTURE PREDICTIONS

The predictions of future fallout depend on the rate and nature of atomic tests and some of the meteorological features just described. Two types of future testing are usually treated: first, cessation of all tests right now and, second, continuation of tests at the same rate and in the same fashion as the past. The purpose of the discussion below is to compare predictions by two models; certain features will be common to both computations.

1. The observed accumulated deposition, from whatever source, equals 25 mc/sq. mile in the latitude band from about 30° to 50°N .
2. Future predictions will be limited to this same band.
3. There have been four years of testing up to the end of 1957. This is not strictly true, but this will be assumed for purposes of comparing the two models.
4. The rate of injection of Sr^{90} into the stratosphere is 9 Mt/year or 4.5 mc/sq. mile/year averaged over the earth.

The two models to account for north temperate latitude fallout are as follows: (1) Stratospheric fallout is uniform over the earth and is being removed at the rate of 10 per cent per year. (2) Stratospheric fallout is being deposited preferentially in the north temperate latitudes; the 30° – 50° band is three times the world average, and the stratospheric removal is at the rate of 20 per cent per year.

Table 2 shows the maximum deposition in the 30° – 50°N latitude band and its time of occurrence if tests are stopped at the end of 1957 (already in error since there have been tests subsequent to that date).

Our estimate is just less than twice the December 1957 fallout value, and the alternate is about the same as the present value. Neither, as we shall shortly see, is very high compared with the fallout amounts if tests continue.

Table 3 shows the comparison for a continuation of tests at the hypothetical past rate.

Once again the model involving nonuniform stratospheric fallout gives higher predictions, but by only 50 per cent even though the nonuniformity factor for stratospheric fallout is three times greater. At times prior to equilibrium the differences between the two models will be even smaller than 50 per cent—in fact, as of today, the difference is zero since both must account for the observed fallout. At other latitudes, the two models also give different forecasts. In the equatorial region, for example, the nonuniform stratospheric fallout theory gives about 100 per cent more fallout at equilibrium than the uniform theory, but it is, of course, much smaller than the fallout in the 30° – 50°N band. At about 45°N , the latitude of the heaviest fallout, the nonuniform stratosphere model predicts about 75 per cent more than the uniform model. It should be noted that the percentages reflect differences between two models and not differences from the correct answer.

One would then like to convert these fallout forecasts to Sr^{90} bone content. However, in doing so, one finds much more uncertainty in the conversion than was found in the estimates of the amount of Sr^{90} fallout. Predictions of this kind must be accepted with considerable reservation for many reasons besides the fact that 100 years is a pretty long-range forecast. They may be too high because of the exchange of food between different geographical regions, because of unavailability of the Sr^{90} to agriculture due to *aging* and plowing of the soil as de-

Table 2—TESTS STOP IN DECEMBER 1957
(Units in millicuries per square mile)

	(1)	(2)
Deposition (12/57)	25	25
Stratospheric content (12/57)	14 (28 Mt)	11.5 (23 Mt)
Fraction removed per year	0.1	0.2
Stratospheric nonuniformity factor	1.0	3.0
Fallout, maximum from Sr ⁹⁰ now in the stratosphere	5.3	19.6
25 mc/sq. mile decayed to maximum	21.6	22.0
Total fallout	27	42
Time of maximum	1963 (5.8 yrs.)	1962 (5.2 yrs.)

Table 3—TESTS CONTINUE AT SAME RATE*
(Units in millicuries per square mile)

	A	B
Tropospheric fallout to 12/57	21	6
Tropospheric injection rate, mc/sq. mile/year	21/4	6/4
Stratospheric fallout to 12/57	4	19
Stratospheric nonuniformity factor	1.0	3.0
Fraction removed per year	0.1	0.2
Prediction of fallout at equilibrium (about 100 years)		
Accumulated tropospheric	210	60
Accumulated stratospheric	$144 \times 1 = 144$	$160 \times 3 = 480$
Total accumulated	354	540

* Common assumptions: total fallout = 25 at $t = 4$ years; stratospheric injection rate = 9 Mt/year or 4.5 mc/sq mile/year.

scribed by Dr. Libby. On the other hand, some local values might be higher owing to small-scale meteorology and soil anomalies and dietary peculiarities.

It appears that, despite wide differences of interpretation of the fallout mechanisms, the uncertainties of deposited fallout on the ground are smaller—by perhaps an order of magnitude—than the conversion of this fallout to Sr⁹⁰ human bone content. The interpretations of hazard from a given predicted Sr⁹⁰ bone content allows even larger differences of opinion than the forecast of how much Sr⁹⁰ will be in man.

7 CONCLUSIONS

The technical conclusions drawn from the discussion are: (1) From evidence of total Sr⁹⁰ fallout and tropospheric fallout, it is found that the stratospheric fallout fraction is markedly nonuniform and has a peak in the temperate latitudes of the northern hemisphere. (2) A seasonal variation in the rate of fallout is present which is probably due to variations in atmos-

pheric conditions. (3) The rate of removal of Sr^{90} from the stratosphere corresponds to 20 per cent per year or faster.

In concluding, we want to repeat that this has been our interpretation of the data. The AEC is collecting information that, it is hoped, will eventually eliminate differences of opinion. Although everyone wants to obtain the best picture of fallout phenomenology, it should be emphasized that the differences in the physical aspects of fallout are still much smaller than the biological aspects.

A STUDY OF FALLOUT IN RAINFALL COLLECTIONS FROM MARCH THROUGH JULY 1956*

William R. Collins, Jr., and Naomi A. Hallden
Health and Safety Laboratory

A study of total β activity and radiostrontium in rain water was undertaken at the Health and Safety Laboratory (HASL) during the Spring of 1956. At that time a survey of atmospheric aerosols and the elemental constituents of rainfall was being conducted by the Cloud Physics Section of the Air Force Cambridge Research Center. The samples from the network of stations were analyzed by a contractor, Skinner and Sherman, of Boston, Mass. HASL received a part of the total month's sample from each site, if there was sufficient sample for both laboratories to run analyses.

Sampling covered the period from March through July 1956 for 61 stations within the continental United States, Bermuda, Newfoundland, and the Azores. The original purpose of the study at HASL was to correlate the amount of fallout in rainfall with the estimate of total fallout from gummed film measurements.

1 PROCEDURES

1.1 Collection

The rain collection devices consisted of 1-liter polyethylene bottles equipped with wide-mouthed funnels that presented a surface area of 0.56 sq ft to the atmosphere. The whole assembly was enclosed in a wooden container designed to be opened manually during rain and closed at other times. Figure 1 is a diagram of this apparatus as it was used in the field.¹

1.2 Analysis

When each sample was received at HASL, the volume was measured and the solution acidified.² Then the sample was evaporated to a small volume, transferred to a glass planchet, and dried for beta counting. This residue was fused with sodium carbonate and the strontium separated with fuming nitric acid. The sample was then stored to allow the Sr^{90} to equilibrate with its yttrium daughter. At this stage the yttrium was separated and precipitated as the oxalate for beta counting.

The Sr^{90} was determined from the counting rate of Y^{90} , and the Sr^{89} was determined by counting total strontium and subtracting the Sr^{90} result.

1.3 Reporting

The Sr^{90} and total β activity are reported in units of millicuries per square mile per month. These values were calculated from the original counting data (disintegrations per minute per aliquot) using the formula,

* Issued as USAEC Report NYO-4889.

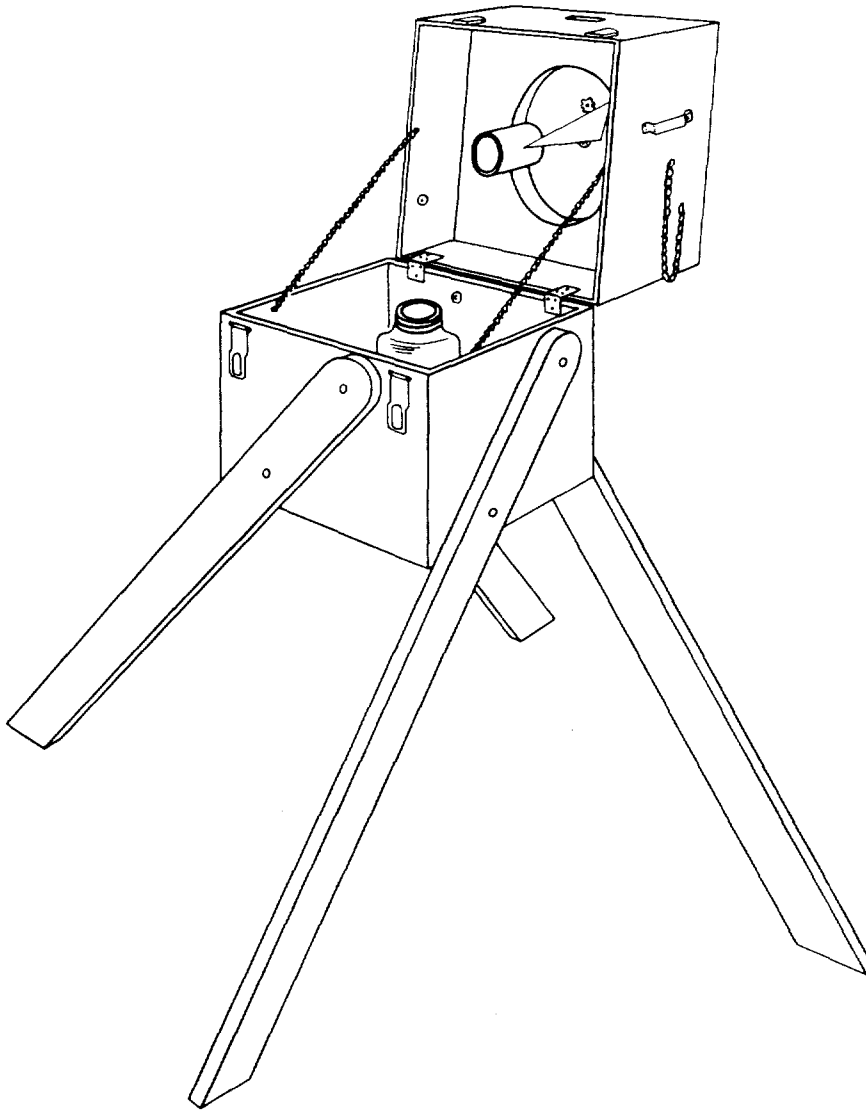

Fig. 1— Air Force collection device used in rain water survey.

$$\text{mc/sq mile/month} = \frac{\text{dis/min/aliquot}}{\text{projected area of funnel, sq ft}} \times \frac{\text{total sample volume}}{\text{aliquot volume}} \times \frac{1}{79.6}$$

For the purpose of these calculations "total sample volume" refers to the volume of the month's rainfall computed from official U. S. Weather Bureau data.³

The Sr⁸⁹ values were obtained in the same way, but for convenience of comparison they were extrapolated to the first day of each sampling month before calculating the Sr⁸⁹/Sr⁹⁰ ratios.

2 FINDINGS

The data are completely summarized in Table 1. Total β activity, Sr⁹⁰ and Sr⁸⁹/Sr⁹⁰ ratios, and rainfall volumes are listed by station for each sampling month. Total β activity is reported as of the counting date since the assignment of a specific burst date is not possible.

For March, 17 stations are reported; for April, 47; for May, 31; for June, 43; and for July, 35. It will be noted that only six locations submitted enough sample for HASL to receive aliquots for all five months. These were West Newton,⁴ Charleston, Tallahassee, Jacksonville, Nantucket, and Albany.

Table 1a—FALLOUT DATA FOR MARCH 1956 RAIN WATER COLLECTIONS

HASL No.	Site No.	Sampling site	Total β activity,* mc/sq mile/month	Sr^{90} , mc/sq mile/month	$\text{Sr}^{89}/\text{Sr}^{90}\dagger$
3616	1	West Newton, Mass.	19 \pm 1.8	1.2 \pm 0.14	14
3617	1	West Newton, Mass.	16 \pm 1.8	0.92 \pm 0.14	18
3619	7	Hatteras, N. C.	10 \pm 0.1	0.83 \pm 0.08	22
3620	8	Charleston, S. C.	19 \pm 3.0	0.45 \pm 0.19	36
3621	11	Tallahassee, Fla.	12 \pm 0.9	0.43 \pm 0.08	19
3622	12	Mobile, Ala.	50 \pm 3.8	2.4 \pm 0.26	20
3623	13	Jackson, Miss.	20 \pm 1.9	1.6 \pm 0.16	15
3624	14	Montgomery, Ala.	25 \pm 0.3	1.6 \pm 0.16	21
3625	15	Lake Charles, La.	16 \pm 1.2	1.2 \pm 0.11	15
3626	17	Nashville, Tenn.	10 \pm 1.1	0.82 \pm 0.10	21
3627	22	Salem, Ore.	54 \pm 2.8	1.7 \pm 0.23	66
3628	24	Jacksonville, Fla.	5.9 \pm 1.6	0.25 \pm 0.11	20
3629	25	Burlington, Vt.	6.6 \pm 0.7	0.51 \pm 0.07	12
3630	26	Nantucket, Mass.	28 \pm 2.3	2.9 \pm 0.20	7.3
3631	28	Albany, N. Y.	17 \pm 1.6	1.1 \pm 0.13	9.3
3632	30	Akron, Ohio	21 \pm 1.8	1.6 \pm 0.24	22
3633	45	Washington, D. C.	33 \pm 1.6	1.1 \pm 0.11	20
3634	63	Tatoosh Island, Wash.	33 \pm 3.0	1.5 \pm 0.23	31

* Total β activity counting date: June 5, 1956.† Sr^{89} extrapolated to first day of sampling month.

Table 1b—FALLOUT DATA FOR APRIL 1956 RAIN WATER COLLECTIONS

HASL No.	Site No.	Sampling site	Total β activity,* mc/sq mile/month	Sr^{90} , mc/sq mile/month	$\text{Sr}^{89}/\text{Sr}^{90}\dagger$
3670	1	West Newton, Mass.	26 \pm 1.9	1.3 \pm 0.15	16
3671	1	West Newton, Mass.	32 \pm 1.5	1.3 \pm 0.09	9.7
3672	3	Little Rock, Ark.	18 \pm 4.4	1.9 \pm 0.38	0
3673	4	Tampa, Fla.	10 \pm 1.4	0.34 \pm 0.10	9.9
3674	5	Bermuda	18 \pm 1.4	0.45 \pm 0.11	11
3676	7	Hatteras, N. C.	80 \pm 4.9	1.6 \pm 0.33	9.0
3677	8	Charleston, S. C.	60 \pm 1.9	0.75 \pm 0.11	12
3678	9	Greenville, S. C.	140 \pm 3.5	1.9 \pm 0.16	9.5
3679	10	West Palm Beach, Fla.	11 \pm 1.2	0.34 \pm 0.09	15
3680	11	Tallahassee, Fla.	17 \pm 1.0	0.58 \pm 0.08	6.3
3681	12	Mobile, Ala.	22 \pm 2.0	0.52 \pm 0.13	10
3682	13	Jackson, Miss.	19 \pm 1.5	1.3 \pm 0.15	3.5
3683	14	Montgomery, Ala.	14 \pm 1.4	0.82 \pm 0.16	6.0
3684	16	Brownsville, Texas	25 \pm 1.9	2.0 \pm 0.20	14
3685	17	Nashville, Tenn.	20 \pm 4.1	1.2 \pm 0.53	11
3686	19	San Diego, Calif.	19 \pm 1.4	0.54 \pm 0.14	5.6
3687	20	Santa Maria, Calif.	6.9 \pm 0.4	0.26 \pm 0.04	5.9
3688	21	Red Bluff, Calif.	12 \pm 0.9	0.85 \pm 0.09	9.5
3689	24	Jacksonville, Fla.	17 \pm 0.8	0.69 \pm 0.08	8.5
3690	25	Burlington, Vt.	42 \pm 1.2	0.79 \pm 0.08	4.9
3691	26	Nantucket, Mass.	14 \pm 1.0	0.60 \pm 0.09	27
3692	27	Caribou, Me.	17 \pm 1.0	0.72 \pm 0.10	4.6
3693	28	Albany, N. Y.	64 \pm 2.4	2.2 \pm 0.18	4.8
3694	29	Montoursville, Pa.	82 \pm 2.5	1.4 \pm 0.15	16
3695	30	Akron, Ohio	74 \pm 1.8	1.5 \pm 0.13	11
3696	31	Indianapolis, Ind.	31 \pm 1.8	1.4 \pm 0.16	8.7
3697	32	Madison, Wisc.	75 \pm 2.7	1.8 \pm 0.20	7.5

Table 1b—(Continued)

HASL No.	Site No.	Sampling site	Total β activity,* mc/sq mile/month	Sr^{90} , mc/sq mile/month	$Sr^{89}/Sr^{90}\dagger$
3698	33	International Falls, Minn.	3.1 \pm 0.2	0.08 \pm 0.02	6.3
3699	34	St. Cloud, Minn.	140 \pm 4.1	1.7 \pm 0.22	12
3700	35	Sault Ste. Marie, Mich.	57 \pm 1.9	0.98 \pm 0.12	0
3701	36	Des Moines, Iowa	55 \pm 2.6	0.67 \pm 0.23	23
3702	37	Columbia, Mo.	27 \pm 1.4	0.83 \pm 0.12	7.3
3703	38	Ft. Worth, Texas	30 \pm 1.2	0.99 \pm 0.10	8.9
3704	39	San Angelo, Texas	30 \pm 0.2	1.0 \pm 0.16	12
3705	42	Wichita, Kans.	27 \pm 1.6	0.34 \pm 0.14	22
3706	44	Grand Island, Nebr.	140 \pm 3.8	2.9 \pm 0.21	7.3
3707	45	Washington, D. C.	40 \pm 1.2	1.2 \pm 0.09	11
3708	46	Huron, S. Dak.	14 \pm 1.6	0.67 \pm 0.14	6.4
3709	50	Sheridan, Wyo.	52 \pm 2.3	1.6 \pm 0.15	8.0
3710	56	Winnemucca, Nev.	31 \pm 2.3	0.90 \pm 0.19	0
3711	58	Boise, Idaho	26 \pm 1.5	0.72 \pm 0.11	12
3712	59	Fresno, Calif.	39 \pm 1.4		
3713	60	Roanoke, Va.	33 \pm 1.5	1.1 \pm 0.12	9.3
3714	61	Scottsbluff, Nebr.	17 \pm 0.2		
3715	64	Grand Rapids, Mich.	31 \pm 1.4	1.4 \pm 0.14	7.0
3716	66	Stephenville, Newf.	60 \pm 2.0	1.7 \pm 0.15	18
3717	67	Laredo, Texas	10 \pm 1.2	0.66 \pm 0.15	7.7

* Total β activity counting date: June 19, 1956.† Sr^{89} extrapolated to first day of sampling month.

Table 1c—FALLOUT DATA FOR MAY 1956 RAIN WATER COLLECTIONS

HASL No.	Site No.	Sampling site	Total β activity,* (mc/sq mile/month)	Sr^{90} , (mc/sq mile/month)	$Sr^{89}/Sr^{90}\dagger$
3834	1	West Newton, Mass.	22 \pm 2.5	0.55 \pm 0.023	33
3835	1	West Newton, Mass.	13 \pm 1.3	1.2 \pm 0.19	0
3836	2	Medford, Oreg.	21 \pm 2.3	3.4 \pm 0.28	9.6
3837	4	Tampa, Fla.	4.4 \pm 1.9	0.21 \pm 0.18	0
3838	6	Azores	110 \pm 34	10.0 \pm 3.8	11
3839	7	Hatteras, N. C.	4.3 \pm 1.2	0.77 \pm 0.15	0.96
3840	8	Charleston, S. C.	5.6 \pm 1.1	0.85 \pm 0.13	0
3841	9	Greenville, S. C.	7.7 \pm 0.9	0.86 \pm 0.11	2.0
3842	10	West Palm Beach, Fla.	23 \pm 1.1	1.1 \pm 0.11	58
3843	11	Tallahassee, Fla.	8.1 \pm 1.4	1.4 \pm 0.23	6.9
3845	15	Lake Charles, La.	11 \pm 1.1	1.1 \pm 0.21	0.6
3846	17	Nashville, Tenn.	5.2 \pm 1.6	0.63 \pm 0.20	2.9
3847	21	Red Bluff, Calif.	17 \pm 1.1	1.4 \pm 0.18	0
3848	24	Jacksonville, Fla.	20 \pm 1.2	1.0 \pm 0.17	14
3849	25	Burlington, Vt.	14 \pm 1.4	0.81 \pm 0.17	17
3850	26	Nantucket, Mass.	23 \pm 1.2	1.5 \pm 0.17	6.6
3851	27	Caribou, Me.	9.0 \pm 0.6	1.1 \pm 0.12	5.7
3852	28	Albany, N. Y.	22 \pm 1.0	1.1 \pm 0.12	11
3853	29	Montoursville, Pa.	16 \pm 1.1	1.1 \pm 0.13	9.5
3854	30	Akron, Ohio	39 \pm 3.9	2.4 \pm 0.57	10
3855	31	Indianapolis, Ind.	19 \pm 2.4	1.8 \pm 0.30	18
3856	32	Madison, Wisc.	28 \pm 3.8	3.1 \pm 0.56	5.0
3857	44	Grand Island, Nebr.	8.1 \pm 0.7	0.56 \pm 0.095	18
3858	47	Bismark, N. Dak.	13 \pm 1.6	1.2 \pm 0.17	8.5

Table 1c—(Continued)

HASL No.	Site No.	Sampling site	Total β activity,* (mc/sq mile/month)	Sr^{90} , (mc/sq mile/month)	$\text{Sr}^{89}/\text{Sr}^{90}\dagger$
3859	59	Fresno, Calif.	25 \pm 1.1	1.1 \pm 0.17	5.2
3860	60	Roanoke, Va.	13 \pm 1.6	0.59 \pm 0.17	21
3861	61	Scottsbluff, Nebr.	15 \pm 2.8	1.5 \pm 0.35	11
3862	62	Yakima, Wash.	5.4 \pm 0.62	0.52 \pm 0.10	0
3863	63	Tatoosh Island, Wash.	7.6 \pm 0.80	0.49 \pm 0.099	2.9
3864	66	Stephenville, Newf.	28 \pm 1.3	1.9 \pm 0.18	9.0
3865	67	Laredo, Texas	17 \pm 2.3	5.1 \pm 0.38	0

* Total β activity counting date: Aug. 23, 1956.† Sr^{89} extrapolated to first day of sampling month.

Table 1d—FALLOUT DATA FOR JUNE 1956 RAIN WATER COLLECTIONS

HASL No.	Site No.	Sampling site	Total β activity,* mc/sq mile/month	Sr^{90} , mc/sq mile/month	$\text{Sr}^{89}/\text{Sr}^{90}\dagger$
3866	1	West Newton, Mass.	12 \pm 1.3	1.4 \pm 0.20	0
3867	1	West Newton, Mass.	13 \pm 2.1	0.47 \pm 0.26	0
3868	2	Medford, Oreg.	7.6 \pm 0.6	0.22 \pm 0.09	22
3869	3	Little Rock, Ark.	8.2 \pm 5.0	3.6 \pm 0.85	1.9
3870	4	Tampa, Fla.	8.3 \pm 2.1	0.50 \pm 0.21	9.9
3871	5	Bermuda	1.8 \pm 1.2	0.65 \pm 0.15	0
3872	7	Hatteras, N. C.	15 \pm 1.4	0.99 \pm 0.20	15
3873	8	Charleston, S. C.	18 \pm 1.8	1.6 \pm 0.24	0.27
3874	9	Greenville, S. C.	14 \pm 1.1	1.1 \pm 0.19	1.6
3875	10	West Palm Beach, Fla.	7.9 \pm 1.4	0.28 \pm 0.16	2.6
3876	11	Tallahassee, Fla.	16 \pm 1.8	1.5 \pm 0.26	3.2
3877	13	Jackson, Miss.	13 \pm 1.6	0.73 \pm 0.24	20
3878	14	Montgomery, Ala.	12 \pm 1.0	0.66 \pm 0.15	14
3879	15	Lake Charles, La.	12 \pm 1.4	0.77 \pm 0.16	6.5
3880	16	Brownsville, Texas	12 \pm 2.5	0.99 \pm 0.40	0
3881	24	Jacksonville, Fla.	30 \pm 2.3	0.55 \pm 0.26	19
3882	26	Nantucket, Mass.	10 \pm 1.0	0.50 \pm 0.14	1.6
3883	27	Caribou, Me.	35 \pm 1.2	2.2 \pm 0.18	5.9
3884	28	Albany, N. Y.	21 \pm 1.1	0.91 \pm 0.15	4.1
3885	29	Montoursville, Pa.	31 \pm 2.3	0.73 \pm 0.23	0
3886	31	Indianapolis, Ind.	18 \pm 2.4	1.7 \pm 0.31	0
3887	32	Madison, Wisc.	22 \pm 1.5	0.74 \pm 0.21	13
3888	33	International Falls, Minn.	8.7 \pm 1.1	0.68 \pm 0.12	3.5
3889	34	St. Cloud, Minn.	38 \pm 2.4	2.0 \pm 0.27	8.6
3890	35	Sault Ste. Marie, Mich.	32 \pm 2.1	1.7 \pm 0.29	0
3891	36	Des Moines, Iowa	20 \pm 1.4	0.44 \pm 0.15	13
3892	37	Columbia, Mo.	13 \pm 1.4	0.56 \pm 0.21	11
3893	40	Amarillo, Texas	18 \pm 1.4	0.94 \pm 0.24	10
3895	43	Goodland, Kans.	6.1 \pm 1.0	0.76 \pm 0.16	6.6
3896	44	Grand Island, Nebr.	78 \pm 3.2	3.1 \pm 0.40	2.0
3897	45	Washington, D. C.	13 \pm 0.9	0.44 \pm 0.12	7.3
3898	46	Huron, S. Dak.	11 \pm 1.8	0.75 \pm 0.20	6.2
3899	47	Bismark, N. Dak.	20 \pm 1.6	0.68 \pm 0.25	13
3900	48	Helena, Mont.	61 \pm 2.1	1.8 \pm 0.19	5.5
3901	49	Glascow, Mont.	14 \pm 1.5	1.1 \pm 0.18	0
3902	50	Sheridan, Wyo.	12 \pm 1.1	0.73 \pm 0.16	4.1
3903	57	Spokane, Wash.	16 \pm 0.9	0.92 \pm 0.12	11
3904	58	Boise, Idaho	7.3 \pm 1.2	0.63 \pm 0.13	0.43

Table 1d—(Continued)

HASL No.	Site No.	Sampling site	Total β activity,* mc/sq mile/month	Sr^{90} , mc/sq mile/month	$\text{Sr}^{89}/\text{Sr}^{90}\dagger$
3905	60	Roanoke, Va.	17 \pm 1.2	0.93 \pm 0.16	0
3906	62	Yakima, Wash.	35 \pm 1.9	0.65 \pm 0.23	15
3907	63	Tatoosh Island, Wash.	71 \pm 3.0	0.48 \pm 0.16	16
3908	64	Grand Rapids, Mich.	19 \pm 2.9	0.64 \pm 0.35	18
3909	66	Stephenville, Newf.	30 \pm 1.3	1.0 \pm 0.12	7.8

* Total β activity counting date: Aug. 23, 1956.† Sr^{89} extrapolated to first day of sampling month.

Table 1e—FALLOUT DATA FOR JULY 1956 RAIN WATER COLLECTIONS

HASL No.	Site No.	Sampling site	Total β activity,* mc/sq mile/month	Sr^{90} , mc/sq mile/month	$\text{Sr}^{89}/\text{Sr}^{90}\dagger$
4218	1	West Newton, Mass.	16 \pm 1.3	0.59 \pm 0.23	20
4219	1	West Newton, Mass.	14 \pm 2.5	3.6 \pm 0.31	0
4220	4	Tampa, Fla.	50 \pm 2.0	1.2 \pm 0.14	36
4221	5	Bermuda	29 \pm 2.3	2.3 \pm 0.34	7.3
4222	8	Charleston, S. C.	34 \pm 3.8	1.0 \pm 0.28	34
4223	9	Greenville, S. C.	37 \pm 3.6	3.1 \pm 0.34	1.8
4224	10	West Palm Beach, Fla.	27 \pm 4.1	\leq 0.47	
4225	11	Tallahassee, Fla.	120 \pm 4.4	1.7 \pm 0.29	61
4226	12	Mobile, Ala.	120 \pm 4.6	2.5 \pm 0.33	64
4227	14	Montgomery, Ala.	57 \pm 3.9	9.6 \pm 0.67	5.5
4228	18	Tucson, Ariz.	59 \pm 6.7	2.1 \pm 0.48	35
4229	24	Jacksonville, Fla.	68 \pm 3.1	1.6 \pm 0.26	52
4230	25	Burlington, Vt.	12 \pm 2.1	1.3 \pm 0.33	11
4231	26	Nantucket, Mass.	11 \pm 1.8	0.52 \pm 0.15	25
4232	27	Caribou, Me.	28 \pm 2.0	0.92 \pm 0.16	15
4233	28	Albany, N. Y.	25 \pm 2.4	0.88 \pm 0.31	2.1
4234	29	Montoursville, Pa.	22 \pm 3.1	1.7 \pm 0.29	5.8
4235	30	Akron, Ohio	65 \pm 6.8	1.9 \pm 0.54	50
4236	31	Indianapolis, Ind.	56 \pm 2.4	0.83 \pm 0.21	42
4237	32	Madison, Wisc.	19 \pm 2.1	0.89 \pm 0.19	19
4238	34	St. Cloud, Minn.	33 \pm 3.0	0.84 \pm 0.15	33
4239	36	Des Moines, Iowa	38 \pm 1.8	1.1 \pm 0.14	30
4240	37	Columbia, Mo.	110 \pm 3.4	1.4 \pm 0.31	41
4241	40	Amarillo, Texas	170 \pm 5.4	2.4 \pm 0.36	58
4242	42	Wichita, Kans.	40 \pm 3.3	0.62 \pm 0.30	67
4243	43	Goodland, Kans.	74 \pm 4.0	0.91 \pm 0.53	41
4244	45	Washington, D. C.	47 \pm 2.0	1.4 \pm 0.20	30
4245	46	Huron, S. Dak.	19 \pm 1.6	0.77 \pm 0.19	32
4246	47	Bismark, N. Dak.	24 \pm 2.1	0.74 \pm 0.33	25
4247	48	Helena, Mont.	21 \pm 1.5	0.90 \pm 0.18	34
4248	49	Glascow, Mont.	6.3 \pm 1.8	0.53 \pm 0.26	0
4249	51	Albuquerque, N. Mex.	22 \pm 1.6	0.69 \pm 0.23	24
4250	54	Las Vegas, Nev.	54 \pm 2.4	0.78 \pm 0.16	40
4251	61	Scottsbluff, Nebr.	18 \pm 1.2	0.24 \pm 0.14	37
4217	66	Stephenville, Newf.	7.7 \pm 1.2	0.63 \pm 0.12	4.4

* Total β activity counting date: Oct. 4, 1956.† Sr^{89} extrapolated to first day of sampling month.

Table 1f—COMPARISON OF AIR FORCE (AF) AND WEATHER BUREAU (WB) RAINFALL DATA

Site No.	Sampling site	Rain, in.									
		March 1956		April 1956		May 1956		June 1956		July 1956	
		WB	AF	WB	AF	WB	AF	WB	AF	WB	AF
1	West Newton, Mass.	5.46	4.44	2.57	2.35	1.90	1.07	1.56	1.14	3.54	1.81
1	West Newton, Mass.	5.46	4.18	2.57	2.23	1.90	1.07	1.56	1.16	3.54	1.91
2	Medford, Oreg.					4.18	1.18	0.80	0.80		
3	Little Rock, Ark.			4.64	1.47			5.08	0.97		
4	Tampa, Fla.			2.08	1.37	2.15	1.25	2.86	1.30	3.69	3.11
5	Bermuda			1.48	1.34			1.41	1.18	5.09	4.54
6	Azores					22.0	0.97				
7	Hatteras, N. C.	2.80	2.52	3.54	0.76	2.04	1.34	5.51	4.17		
8	Charleston, S. C.	2.45	1.43	2.39	1.45	4.62	2.87	7.69	4.12	10.6	3.01
9	Greenville, S. C.			6.57	3.70	3.88	2.10	2.44	1.61	8.14	4.18
10	West Palm Beach, Fla.			1.26	0.76	3.39	2.69	1.94	1.24	2.98	1.34
11	Tallahassee, Fla.	2.00	1.83	1.90	1.83	5.71	2.73	7.32	4.58	9.78	6.07
12	Mobile, Ala.	9.74	2.29	2.15	1.53					1.01	2.98
13	Jackson, Miss.	6.52	3.24	4.67	2.29			7.37	2.63		
14	Montgomery, Ala.	8.69	5.72	2.03	1.83			3.69	2.37	8.92	3.78
15	Lake Charles, La.	4.38	2.59			5.17	3.59	1.78	1.30		
16	Brownsville, Texas			4.75	2.00			4.02	1.49		
17	Nashville, Tenn.	4.08	3.40	4.23	1.53	2.87	1.57				
18	Tucson, Ariz.									2.70	0.90
19	San Diego, Calif.			1.56	0.99						
20	Santa Maria, Calif.			0.80	1.58						
21	Red Bluff, Calif.			1.27	1.18	4.04	3.43				
22	Salem, Oreg.	5.91	4.31								
24	Jacksonville, Fla.	0.81	0.29	2.33	2.10	3.98	3.63	7.87	4.06	8.25	3.62
25	Burlington, Vt.	2.37	1.95	2.47	1.95	4.74	3.74			4.06	1.70
26	Nantucket, Mass.	6.53	3.99	2.26	1.95	3.46	2.94	2.29	1.53	2.75	1.68
27	Caribou, Me.			2.37	1.83	2.42	2.21	3.35	2.71	2.86	1.53
28	Albany, N. Y.	4.76	2.29	2.64	1.11	3.08	2.23	1.83	1.53	2.76	1.32
29	Montoursville, Pa.			3.08	1.53	3.33	2.25	3.02	1.47	7.17	2.29
30	Akron, Ohio	4.23	1.95	3.51	2.14	9.60	1.85			5.12	0.92
31	Indianapolis, Ind.			4.50	2.14	4.96	1.63	3.48	1.53	3.93	2.06
32	Madison, Wisc.			3.54	1.07	5.11	2.52	3.24	1.35	4.50	1.75
33	International Falls, Minn.			0.24	0.90			1.06	1.21		
34	St. Cloud, Minn.			2.01	1.14			5.46	2.21	4.79	3.11
35	Sault Ste. Marie, Mich.			1.70	1.41			4.22	2.01	2.76	2.54
36	Des Moines, Iowa			1.24	0.76			1.29	0.95		
37	Columbia, Mo.			2.25	1.85			1.98	1.65	6.75	4.31
38	Fort Worth, Texas			3.12	2.75						
39	San Angelo, Texas			1.44	1.03						
40	Amarillo, Texas							2.03	1.61	2.82	1.11
42	Wichita, Kans.			1.46	0.99					2.51	1.28
43	Goodland, Kans.							0.59	0.93	1.93	0.93
44	Grand Island, Nebr.			1.96	1.03	2.43	2.25	3.51	1.53		
45	Washington, D. C.	3.69	2.48	2.25	2.10			2.12	3.23	5.82	4.31
46	Huron, S. Dak.			1.23	1.79			2.11	0.86	3.47	1.56
47	Bismark, N. Dak.					3.83	1.81	2.36	1.53	2.78	1.34
48	Helena, Mont.							1.80	1.60	1.04	0.86
49	Glascow, Mont.							1.68	1.30	1.62	0.90
50	Sheridan, Wyo.			1.91	1.53			1.07	0.92		

Table 1f (Continued)

Site No.	Sampling site	Rain, in.									
		March 1956		April 1956		May 1956		June 1956		July 1956	
		WB	AF	WB	AF	WB	AF	WB	AF	WB	AF
51	Albuquerque, N. Mex.									1.49	1.05
54	Las Vegas, Nev.									1.64	1.03
56	Winnemucca, Nev.			0.78	1.76						
57	Spokane, Wash.							1.18	1.26		
58	Boise, Idaho			1.62	1.51			0.80	0.77		
59	Fresno, Calif.			1.38	1.26	0.81	0.69				
60	Roanoke, Va.			3.12	1.72	1.58	1.07	1.72	1.46		
61	Scottsbluff, Nebr.			1.54	0.95	2.75	0.76			2.08	1.26
62	Yakima, Wash.					0.48	0.78	1.81	1.03		
63	Tatoosh Island, Wash.	9.88	8.39			1.07	0.89	6.35	4.58		
64	Grand Rapids, Mich.			4.39	2.29			3.36	1.18		
66	Stephenville, Newf.			1.57	0.92	4.34	3.62	3.21	2.29	2.08	1.51
67	Laredo, Texas			1.62	1.16	3.80	1.53				

Averaged data and ranges for each month are shown in Table 2.

Table 2—SUMMARY OF FALLOUT DATA FOR RAIN WATER COLLECTIONS FROM MARCH THROUGH JULY, 1956

Sampling month	Total β activity, mc/sq mile/month		Sr^{90} , mc/sq mile/month		Sr^{89}/Sr^{90}	
	Average	Range	Average	Range	Average	Range
March	22	5.9-54	1.2	0.25-2.9	22	7.3-66
April	39	3.1-140	1.1	0.34-2.9	9.7	0.0-23
May	19	4.3-110	1.6	0.21-3.4	9.3	0.0-33
June	20	6.1-78	1.0	0.22-3.6	7.0	0.0-22
July	44	6.3-170	1.5	0.24-3.6	29	0.0-67

3 DISCUSSION

The data present several possible modes of analysis. Fallout debris in rain water can be dated; its activity can be correlated with the amount of rainfall; and the relationship between total fallout and rain water activity can be established. It is impossible to predict that there will be correlation between activity and amount of rainfall over the entire sampling network because the amount of activity in the atmosphere is not necessarily constant but varies with local conditions. However, it is possible that better correlation might be found by investigating a fraction of the sampling network over which conditions are more likely to be uniform.

The age of fallout can be estimated in two ways: one from the Sr^{89}/Sr^{90} ratio, which varies as a function of time after burst; and the other from percent contribution of Sr^{90} to total β activity. The theoretical Sr^{89}/Sr^{90} ratios used to calculate burst dates were obtained from the Hunter and Ballou yield data for these isotopes and their most recently reported half-life values.⁵ The expected percent Sr^{90} in total β activity as a function of time was obtained in the same way. The approximate burst times have been calculated for all the data, and the average burst months for each month's samples, as obtained by both methods, are listed in Table 3.

From Table 3 it can be seen that the Sr^{90} contribution to total β activity is high, indicating old debris. At the same time, the Sr^{89}/Sr^{90} ratio is large enough for a much later burst date

Table 3— ESTIMATED BURST DATES OF FALLOUT IN RAIN WATER

Sampling month	Burst month (calculated from average Sr^{89}/Sr^{90} ratios)	Burst month (calculated from average % Sr^{90})
March	September 1955	March 1954
April	August 1955	November 1954
May	September 1955	November 1951
June	October 1955	February 1954
July	February 1956	October 1954

to be realized. This is possibly due to enrichment of the Sr^{90} in fallout that would occur in a mixture of material from different test series.

Therefore, the Sr^{89}/Sr^{90} ratio is the more sensitive indicator of the age of fallout and can be expected to yield a more valid estimation of relative freshness than the percent Sr^{90} . It is apparent, then, that July rainout is of more recent origin than any of the preceeding months.

It has been hypothesized that fallout material that is entering the troposphere from the stratosphere has a selective entrance zone near the mid-latitude region. If the fallout material is old and originated from a high-yield device, it is probable that the debris is stratospheric, and upon entrance into the troposphere it can be brought down in rainfall. It follows that there would be more activity in rain occurring near the mid-latitudes.

Scatter diagrams of Sr^{90} activity vs inches of rainfall for all months are plotted in Fig. 2. All values, regardless of location, are plotted, but stations below $40^{\circ}N$ (an arbitrary limit) appear as black dots on the plots. It is visually apparent from the scatter of the points that

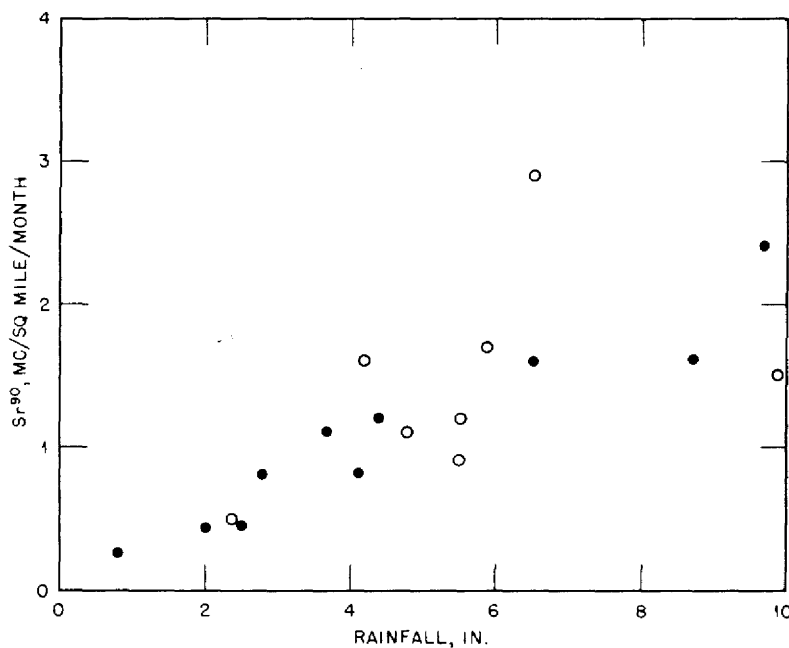

Fig. 2a— Regression of Sr^{90} in rain water on the amount of rainfall in March 1956.

there is little correlation on an over-all basis. Considering a separation of the data at $40^{\circ}N$, there is better correlation found among southern stations. The specific activity (millicuries per square mile per inch) of rain water for these stations is generally lower than for northern sites for the duration of the sampling, and the specific activity at each site does not vary considerably from month to month.

Since it has been possible to obtain better correlation by using the $40^{\circ}N$ separation, this idea is expanded by considering even smaller areas. For this purpose four areas in different

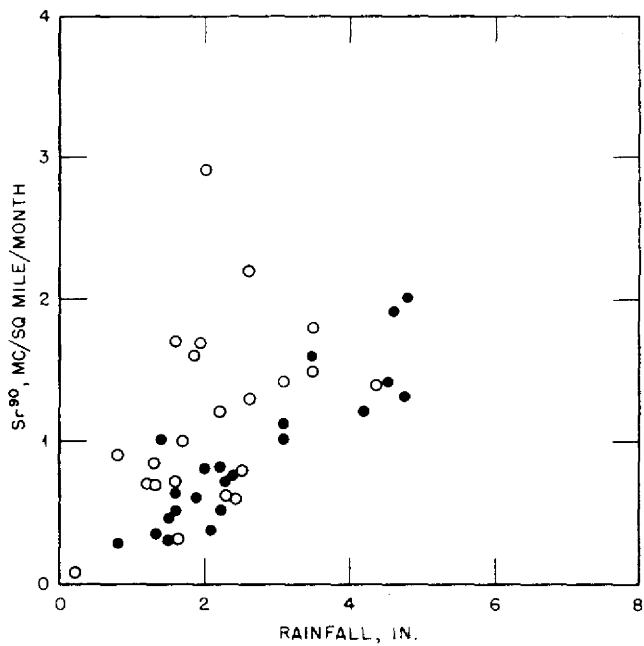

Fig. 2b—Regression of Sr^{90} in rain water on the amount of rainfall in April 1956.

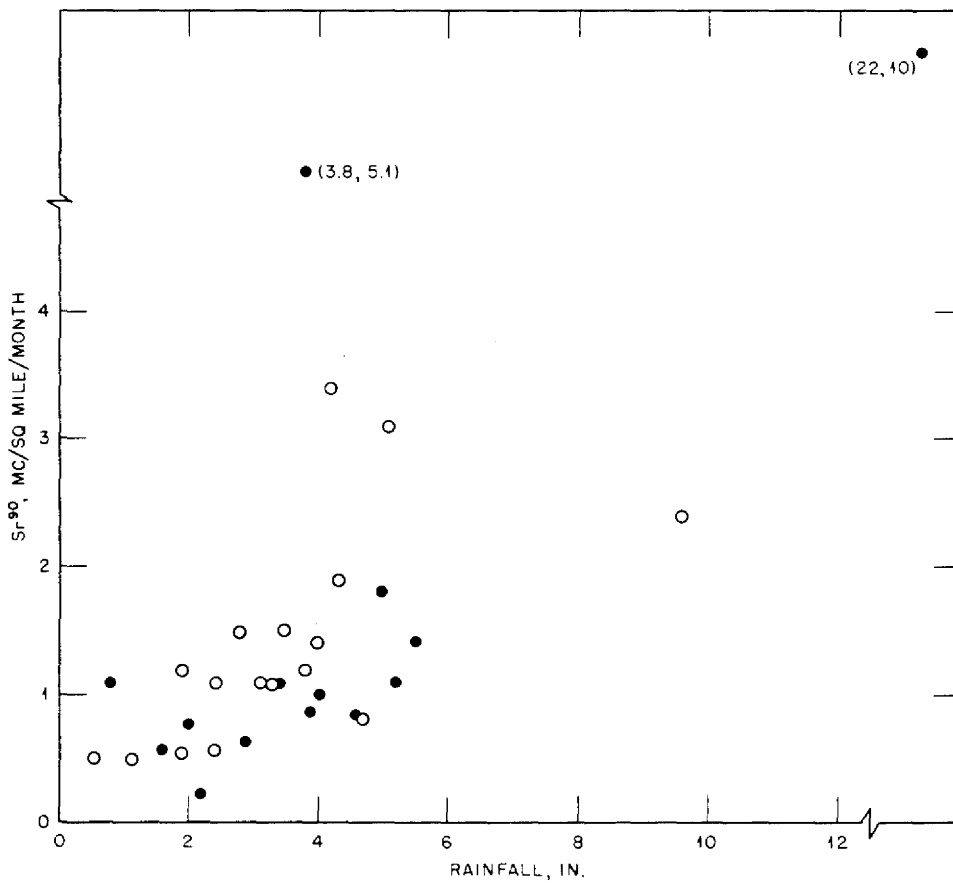

Fig. 2c—Regression of Sr^{90} in rain water on the amount of rainfall in May 1956.

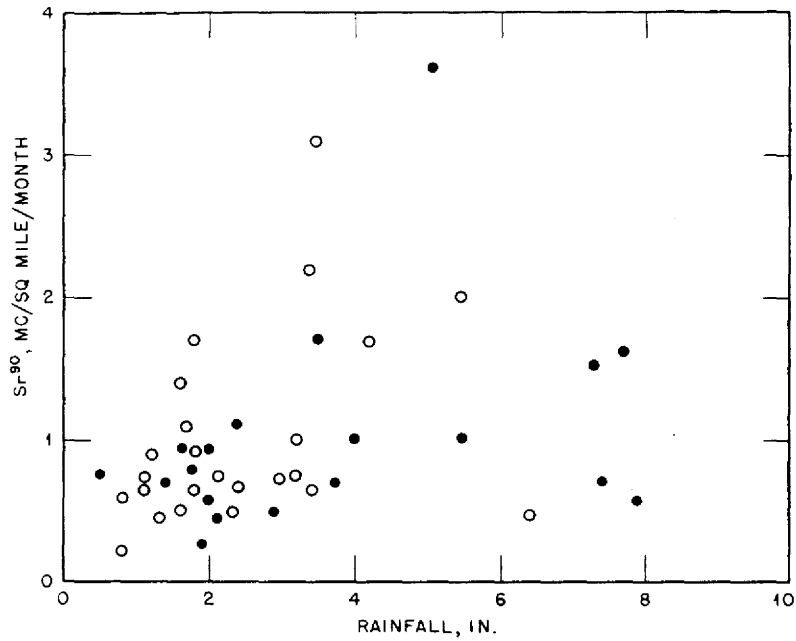

Fig. 2d—Regression of Sr^{90} in rain water on the amount of rainfall in June 1956.

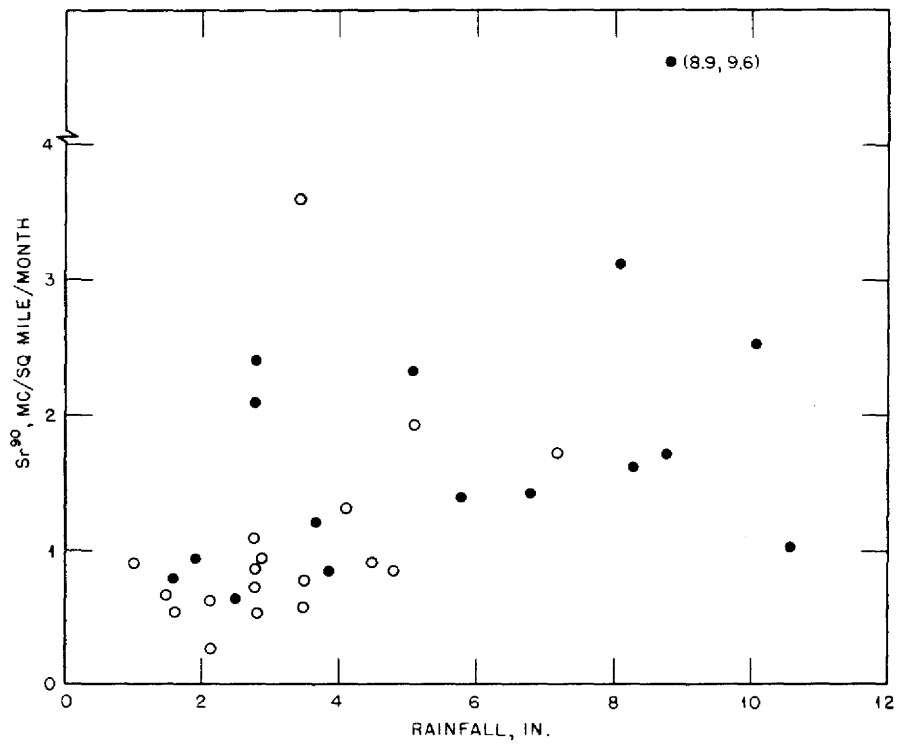

Fig. 2e—Regression of Sr^{90} in rain water on the amount of rainfall in July 1956.

parts of the sampling network were chosen on the basis of uniformity of specific activity throughout the sampling period. These areas represent the northeast, northwest, southeast, and the southwest sections of the continental United States. The data for each of these areas is plotted in Fig. 3.

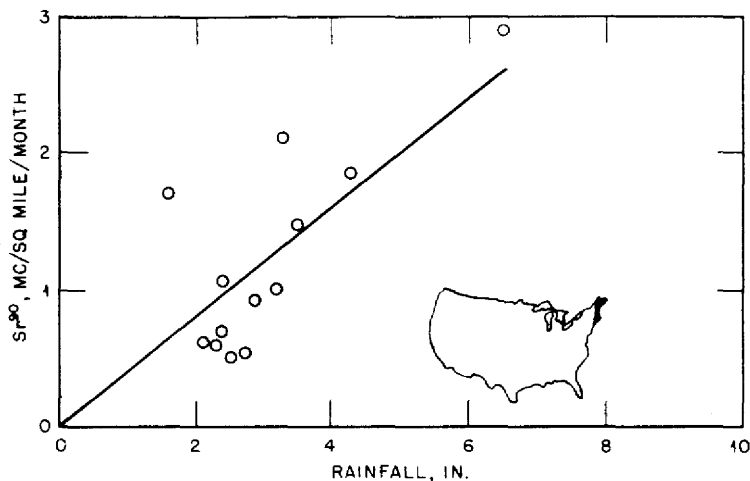

Fig. 3a—Regression of Sr⁹⁰ in rain water on the amount of rainfall collected March through July 1956 at Caribou, Nantucket, and Stephenville.

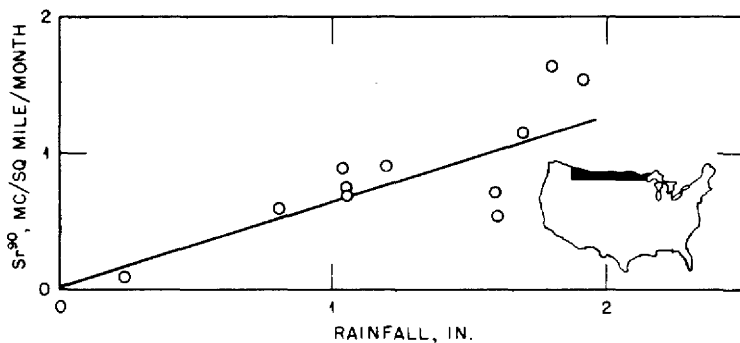

Fig. 3b—Regression of Sr⁹⁰ in rain water on the amount of rainfall collected March through July 1956 at International Falls, Glasgow, Helena, Boise, and Spokane.

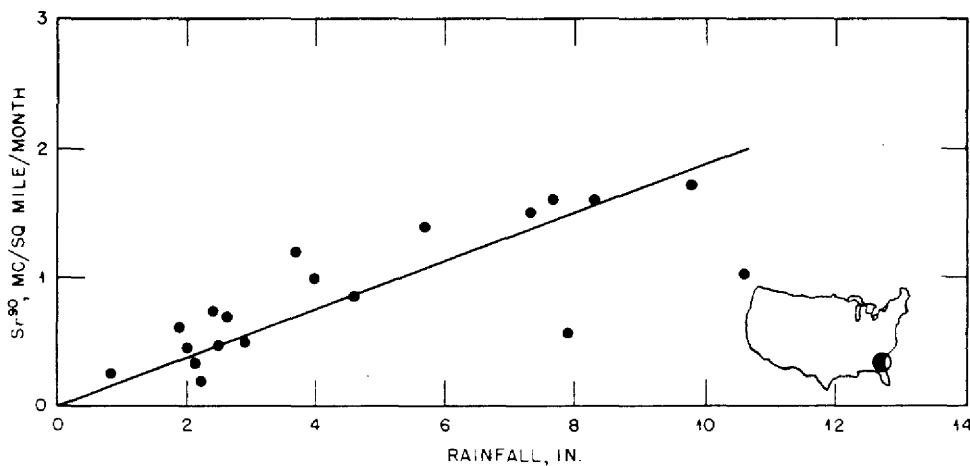

Fig. 3c—Regression of Sr⁹⁰ in rain water on the amount of rainfall collected March through July 1956 at Tampa, Tallahassee, Jacksonville, and Charleston.

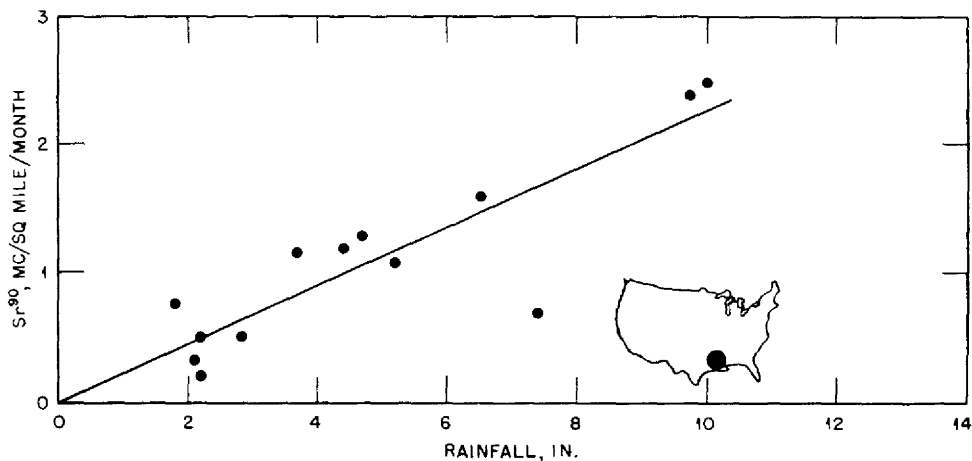

Fig. 3d—Regression of Sr^{90} in rain water on the amount of rainfall collected March through July 1956 at Mobile, Lake Charles, Jackson, and Little Rock.

From these plots it is obvious that activity is proportional to the amount of rainfall within each area. Correlation coefficients for all graphs are summarized in Table 4.

Table 4—CORRELATION COEFFICIENTS FOR THE REGRESSION OF Sr^{90} ON INCHES OF RAINFALL

Fraction of total sampling area	Time of sampling					March—July
	March	April	May	June	July	
Total sampling area	0.77	0.57	0.86	0.31	0.47	0.60
Above 40° latitude	0.46	0.45	0.63	0.37	0.42	0.43
Below 40° latitude	0.95	0.87	0.90	0.66	0.37	0.72
Northeast						0.77
Northwest						0.78
Southeast						0.77
Southwest						0.87

The next step in the analysis of the rain water data is made by comparing Sr^{90} in rain to that measured by various pot type collectors. However, most of these devices collect total fallout and have sampling networks that do not coincide with the rain water stations. Therefore, a comparison of these results can only indicate the relative levels of rainout to total fallout. This comparison is shown in Table 5 in which the average values of fallout in rain

Table 5—COMPARISON OF FALLOUT (MC/SQ MILE/MONTH) IN RAIN WATER TO TOTAL FALLOUT⁶

Sampling month	Air Force rain water		New York roof pots		New Haven dustfall		Sr^{90} in Pittsburgh rainfall
	Average total β activity	Average Sr^{90}	Total β activity	Sr^{90}	Total β activity	Sr^{90}	
March	20	1.3	46	1.9			1.3
April	45	1.3	83	0.8	63	2.3	1.0
May	21	1.2	71	1.0	42	0.6	1.5
June	17	0.8	27	0.8	28	0.6	1.4
July	27	1.5	77	0.6			0.6

water are obtained by considering the 10 rainfall sampling stations nearest New Haven, Pittsburgh, and New York.

The best comparison between rain water data and total fallout should be obtained using gummed film data, since the gummed film network covers the same area as the rain water stations and was operated over the same sampling period. The positioning of the two sampling networks is shown in Fig. 4. Because only 14 of the stations are duplicated, geographic ex-



Fig. 4— Location of rain water and gummed film sampling sites in the United States. +, Air Force site, O, gummed film site.

trapolation is employed to obtain values for the rain water sites that are not covered by gummed film stations. Distances of 100, 150, 200, and 300 miles were used as extrapolation radii, but it was found that the distance used made little difference in the final correlation. The optimum distance was chosen as 150 miles because, when circles of this radius were drawn around the rain water sites, a maximum number of gummed film stations fell within the given areas with a minimum number of circles overlapping.

With this scheme there are 11 results that may be compared in March; 30 in April; 20 in May; 25 in June; and 23 in July. The highest correlation coefficient obtained, using the gummed film data⁷ as predicted Sr^{90} and rain water data as measured Sr^{90} , is 0.49. This relation is shown in Fig. 5, using May 1956 as an illustration. The ratios of average Sr^{90} in rain to average Sr^{90} in gummed film range from 1.9 to 45. Table 6 is a summary of this comparison.

4 CONCLUSIONS

The relation between fallout in rainfall with total fallout measurements using the pot type of collector is good, but there is poor agreement between the rain water data and gummed film measurements. It is believed that the Sr^{90} values calculated from gummed film activity are low owing to incorrect arbitrary burst assignments used in the calculations.⁸

Considering only the rainfall data, no over-all correlation exists between rainfall and the level of Sr^{90} activity. It is interesting that, although the testing of atomic weapons takes place in southern latitudes, the Sr^{90} deposition is higher at northern latitudes. If the fallout were of recent tropospheric origin, this northward movement could be due to surface winds. However, the high percentage of Sr^{90} indicates that the debris is old and entered the troposphere from the stratosphere.

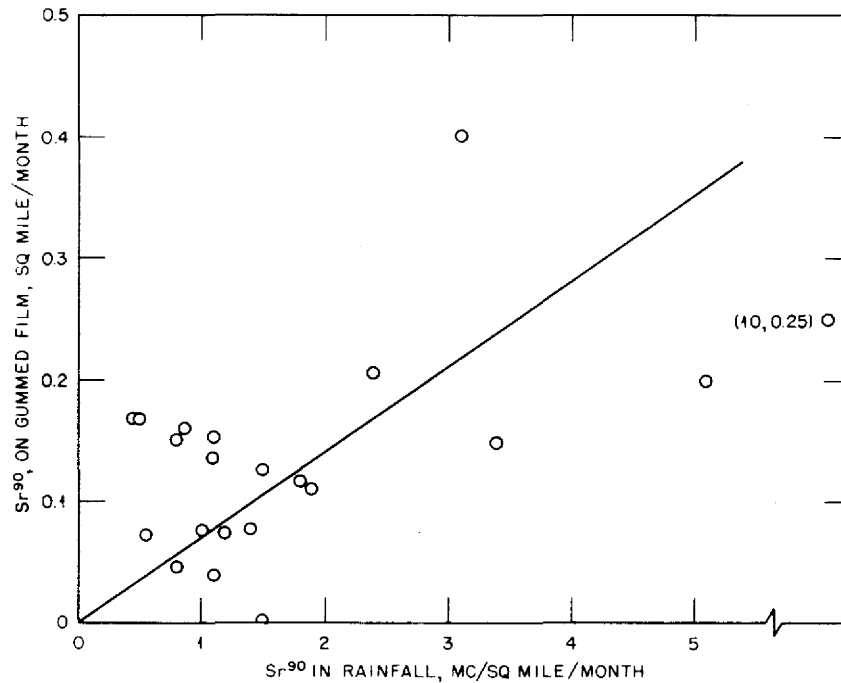

Fig. 5—Regression of Sr^{90} in gummmed film on Sr^{90} in rain water from 20 stations in May 1956.

Table 6—COMPARISON OF Sr^{90} IN GUMMED FILM TO Sr^{90} IN RAIN WATER

Sampling month	Average Sr^{90} in rain water (mc/sq mile/month)	Average Sr^{90} in gummmed film (mc/sq mile/month)	Ratio	Correlation coefficient
March	1.2	0.44	2.7	0.24
April	1.1	0.57	1.9	0.20
May	1.6	0.14	11	0.49
June	1.0	0.022	45	0.02
July	1.5	0.063	24	0.01

Since there is more Sr^{90} in the northern region, the activity levels in the troposphere are not uniform over the United States. However, when areas are chosen that are small enough to have nearly the same tropospheric activity levels, the Sr^{90} in rain water is proportional to the amount of precipitation.

There is some justification for accepting the theory that a selective entrance zone for stratospheric fallout exists. This is demonstrated in the initial separation of data, wherein northern sites show little correlation although they have a higher mean level per inch of rain. Rainout for the southern stations is definitely proportional to the amount of rainfall, suggesting a more uniform activity level in the atmosphere. It should be noted that no correlation for southern stations existed in July, when there was fresh fallout.

5 SUGGESTIONS

The validity of the assumptions made from these data suffer from several sources of error. In the event a more comprehensive study is undertaken in the future, there are several changes that should be made.

1. The scope of the experiment should be extended to operate over a larger area and a longer period of time.

2. Sampling methods should be improved to preclude missing parts of the rain sample.
3. Provision should be made to assay total fallout at the sites of rainfall measurements.

REFERENCES AND NOTES

1. Instructions for Operation of Air Force Rain Gauges (AF-1210).
2. In a considerable number of sample aliquots, miscellaneous debris and insoluble oils were present. In these cases the samples were filtered and the residue discarded prior to analysis.
3. Official Weather Bureau data were used to correct the Air Force total sample volume data at the suggestion of Dr. Christian Junge of AFCRC and Mr. F. I. Sullivan of Skinner and Sherman. This was to compensate for portions of the sample missed when the collector was not opened in time to collect all the rain.
4. In addition to the normal rain water sampling, another series of collections was run at West Newton, Mass., with the collector open at all times. No consistent relation between the two sets of data was found at HASL, however, and both results were used in this report as the best approximation of activity levels at that station.
5. Hallden and Harley, HASL Laboratory Report 56-9.
6. J. Harley et al., USAEC Report NYO-4862.
7. HASL Fallout Summary, March through July 1956.
8. Appreciation is expressed to the HASL staff members who were associated directly and indirectly with this project. Among them were Helen W. Keller and Seymour Tarras, who helped in various phases of the analytical procedures.

ABST

mate
const
chang
the c
produ

pot n

may
later

1 II

invol

isotc
eval
The

tivel

time
may
This
mor

site
is c

Swe
of a

A NEW METHOD FOR COLLECTION OF FALLOUT MATERIAL FROM NUCLEAR DETONATIONS*

George A. Welford and John H. Harley

Health and Safety Laboratory

ABSTRACT

A collection system is presented and evaluated for the off-site measurement of fallout material. The collector consists of a funnel, ion-exchange column, and leveling device—all constructed of polyethylene. The ion-exchange column is packed with paper pulp, anion exchange resin, and cation exchange resin. This unit may be exposed for monthly periods, and the column may be conveniently shipped to a central laboratory for analysis of the fission-product content.

The results of a six-month evaluation period are reported and are compared with the open-pot method of collecting fallout material at the same physical site.

The total activity may be collected by ashing the paper pulp and resin. Individual isotopes may be eluted, or the three absorbents may be separated for gamma spectral analysis and later chemical analysis.

1 INTRODUCTION

The Health and Safety Laboratory (HASL) of the Atomic Energy Commission has been involved in the off-site collection of radioactive debris from nuclear detonations since 1951.

In order to estimate the distribution of fallout, the total beta activity and some individual isotopes are measured per unit area at a sufficient number of stations to permit a world-wide evaluation. Various systems have been devised to collect this material simply and efficiently. The three systems presently in use and their main difficulties are:

1. Direct analysis of surface soil:¹ The low specific activity requires sampling of a relatively large area of virgin soil and makes the analytical problems extremely difficult.
2. Settled dust on gummed paper:² This is the largest system in operation at the present time because of the convenience of operation by untrained personnel. Only total beta activity may be measured, and doubt has been expressed concerning the efficiency of this system. This doubt may be erased by comparison with collection systems whose efficiency could be more simply evaluated.
3. Open-pot collectors:² This system requires some laboratory facilities at the collection site for transfer from the collector. The possibility of sample loss in transfer and shipment is considerable.

The ion-exchange collection system was first described by B. Aler and K. Edvarson of the Swedish Research Institute of National Defense.³ Their work was directed toward the collection of a sample for gamma spectroscopy, and no data were shown for collection efficiency. The

* Prepared for presentation at the American Chemical Society, San Francisco, April 1958.

work at HASL has involved the improvement of the physical design and the comparative testing for collection efficiency.

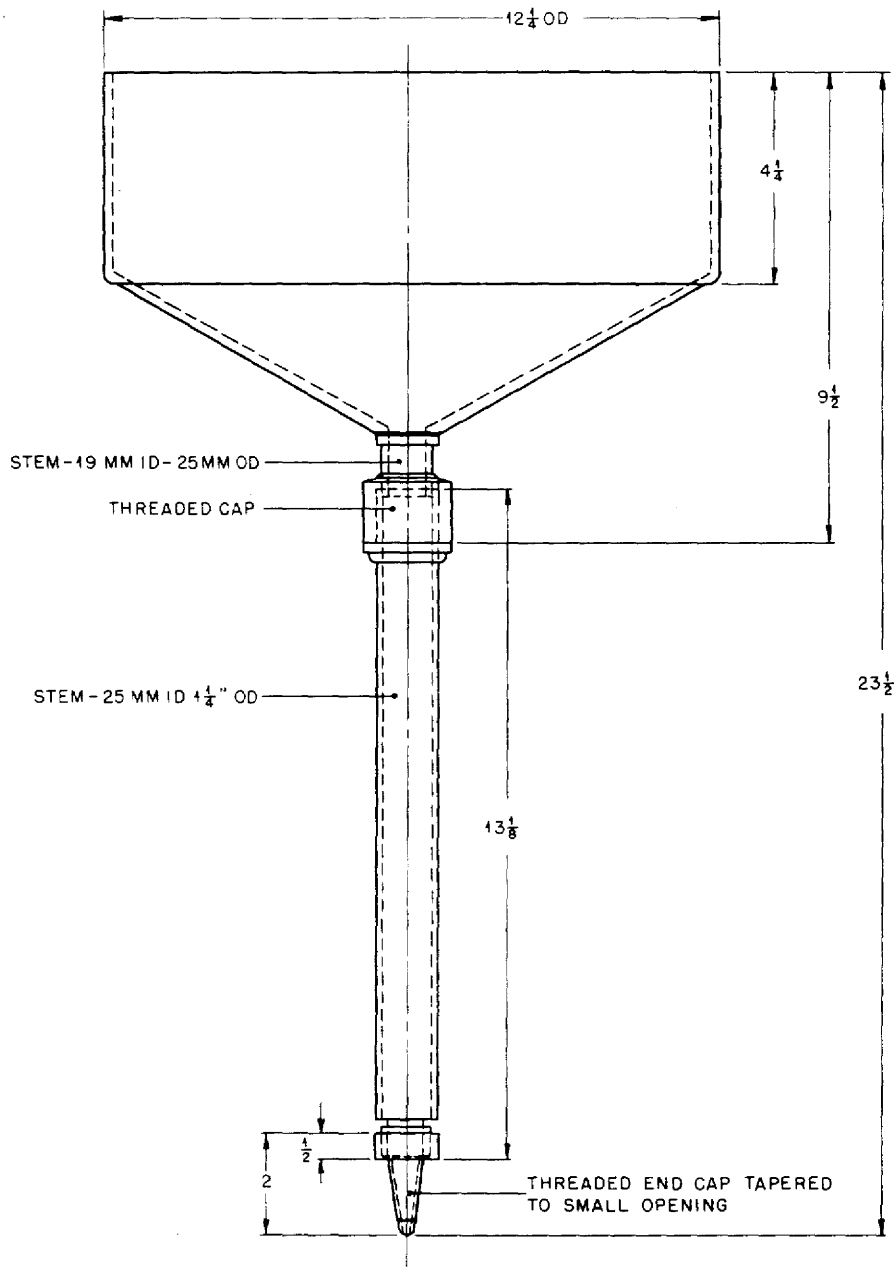

Fig. 1— Ion-exchange fallout collector.

2 DESCRIPTION OF APPARATUS

A schematic diagram of the ion-exchange fallout collector is shown in Fig. 1. This unit consists of a funnel, ion-exchange column, and leveling device—all constructed from polyethylene. The funnel is welded to a threaded cap that may be attached to the top of the ion-exchange column. The bottom of the column is also threaded for a tapered cap with attached leveling tube. The funnel and tapered caps may be replaced with standard bottle caps for shipment. The collector was fabricated for HASL by Bel-Art Products, West New York, N. J.

The leveling device (not shown in the schematic) consists of polyethylene tubing extended from the bottom of the column to a Y-tube above the paper pulp in the column. This prevents the column from running dry during the collection period.

3 PREPARATION AND ANALYSIS OF COLLECTOR

3.1 Preparation

The ion-exchange column is packed with a triple filter consisting of paper pulp, anion exchange resin, and cation exchange resin. The *paper pulp* is Whatman No. 41 filter paper blended in a Waring blender with distilled water. The *anion exchange resin*, IRA 400 Amberlite resin, is used throughout this paper. This resin is prepared by an aqueous and nonaqueous extraction of the commercial product followed by conversion to the chloride form and thorough washing with distilled water. Dowex 50 × 16 is used as the *cation exchange resin*. This resin is treated by an aqueous and nonaqueous extraction, converted to the hydrogen form, and washed with distilled water.

A glass wool plug is added to the bottom of each column and cation exchange resin, anion exchange resin, and paper pulp are added in this order. Approximately 3 in. or 50 ml of wet settled resin and 1 in. of paper pulp are packed into an ion-exchange column filled with distilled water. Care is taken to prevent the formation of air pockets.

3.2 Care of Collector

During dry periods the funnel is rinsed and polished every three days. At the end of the exposure period, any residue on the funnel is washed into the column with water.

3.3 Analysis

The total activity may be determined by ashing the paper pulp and resin; individual isotopes may be eluted, or the three absorbents may be separated for gamma spectral analysis and later chemical analysis. The data for total beta activity in this report was obtained by ashing the absorbents and counting the residue. The Sr^{90} , Sr^{89} , and Ba^{140} data were obtained by chemical separation⁴ of these isotopes from the ash.

4 FALLOUT IN NEW YORK CITY (JUNE TO DECEMBER 1957)

Table 1 summarizes the Sr^{90} , Sr^{89} , and Ba^{140} activities found in fallout in New York City from June to December 1957 by the ion-exchange fallout collection system. The total beta activity level, counted approximately 14 days after the end of each sampling month, decreased from a high of 163 mc/sq mi in July to a low of 46.4 mc/sq mi in November. A rise in activity to 81 mc/sq mi occurred in December, probably due to the announced Russian tests in November.

5 EFFICIENCY OF COLLECTION UNIT

The efficiency of the ion exchange fallout collection unit was measured by the following methods:

1. Per cent of activity in effluent: The effluent from the collector during the monthly exposure was retained in a covered polyethylene pail. This solution was evaporated and the residue analyzed for total beta activity. In all cases the activity found was less than 5 per cent of the total activity of each unit. No marked discrimination of isotopes was found in the effluent.

2. Collector comparison: During the six month period, duplicate units of the following description were exposed side by side: (1) funnel and column containing the three filtering media, (2) funnel and column containing no filtering medium, and (3) open-pot collectors.

Figure 2 gives the total beta activity for each collection device plotted against the counting date. Each point represents the collection from a month. From these data it is evident that the funnel and resin column method of collecting fallout is equivalent to the pot method. Table 2

Table 1—Sr⁹⁰, Sr⁸⁹, AND Ba¹⁴⁰ ACTIVITIES IN FALLOUT
IN NEW YORK CITY

Month	Average mc/sq mi		
	Sr ⁹⁰	Sr ⁸⁹ *	Ba ¹⁴⁰ *
July	0.34	13.0	45.5
August	0.44	26.0	60.0
September	0.43	20.3	33.1
October	0.34	20.9	20.9
November	0.41	8.5	2.43
December	0.62	12.7	3.41

* Extrapolated from counting date to last day of sampling month.

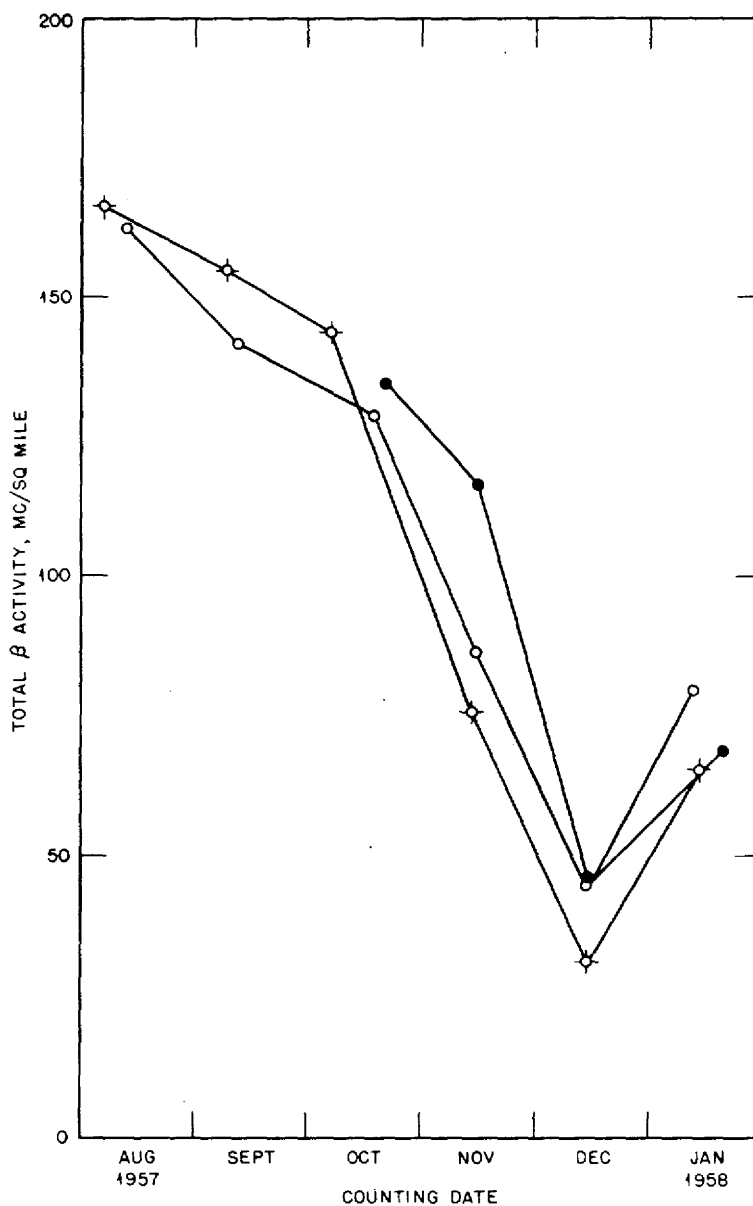

Fig. 2—Comparison of total β activity from three collection units. ◇, roof pot; ●, roof funnel; ○, roof funnel and resin.

Table 2—COMPARISON OF MONTHLY COLLECTIONS OF Sr⁹⁰ BY FUNNEL UNITS

Month	Average mc/sq. mi	
	A*	B†
July	0.34	
August	0.44	0.55
September	0.43	0.39
October	0.34	0.41
November	0.41	0.42
December	0.62	0.57

* Funnel collector plus ion-exchange resins and filter pulp.

† Funnel collector, no filtering media.

gives the Sr⁹⁰ results obtained by chemical analyses of the ash. The data are also in good agreement.

6 LOCATION OF FISSION PRODUCTS

Owing to the solubility of some of the isotopes in water, there is a separation inherent in the collection system. Analysis shows that cerium and other rare earths are principally located in the filter pulp. During the period of observation, the mean insoluble fraction was 43 per cent. Zirconium, niobium, and ruthenium are found in the anion exchanger; cesium, barium, and strontium are found in the cation exchanger. During the later months of 1957, some (<10 per cent) strontium activity was found in the paper pulp.

7 SUMMARY

The funnel and resin column method of collecting fallout is equivalent to the other systems presently in use although it is impossible to make comparisons with an absolute collector. The convenience of operation by untrained personnel at remote sites is a considerable improvement over present methods which require laboratory facilities for preparation of the sample prior to shipping. The saving in cost and radiochemical effort by use of a central processing facility is apparent since any site collects only one or two samples per month.

ACKNOWLEDGMENTS

Acknowledgments are due to the HASL personnel, in particular Doris Sutton, Robert Morse, Ira Cohen, and William Collins, Jr., for their assistance in this development.

REFERENCES

1. G. H. Hamada and E. P. Hardy, Jr., USAEC Report HASL-33, Apr. 7, 1958.
2. M. Eisenbud and J. H. Harley, *Science* 124: (3215) 251-255 (1957).
3. B. Aler and K. Edvarson, Report to the United Nations, A/AC.82/R.52, Apr. 17, 1957.
4. J. H. Harley and I. B. Whitney, *Manual of Standard Procedures*, USAEC Report NYO-4700.