

OPERATION HARDTACK

Projects 2.9/2.12b

Gamma Dose From Very-Low-Yield Bursts

April-October 1958

Headquarters Field Command
Defense Atomic Support Agency
Sandia Base, Albuquerque, New Mexico

August 24, 1960

NOTICE

This is an extract of WT-1677, which remains classified CONFIDENTIAL/FORMERLY RESTRICTED DATA as of this date.

Extract version prepared for:

Director
DEFENSE NUCLEAR AGENCY
Washington, D.C. 20305

1 OCTOBER 1983

**Approved for public release;
distribution unlimited.**

REPORT DOCUMENTATION PAGE		READ INSTRUCTIONS BEFORE COMPLETING FORM
1. REPORT NUMBER WT-1677 (EX)	2. GOVT ACCESSION NO.	3. RECIPIENT'S CATALOG NUMBER
4. TITLE (and Subtitle) Operation HARDTACK - Projects 2.9/2.12b Gamma Dose From Very-Low-Yield Bursts		5. TYPE OF REPORT & PERIOD COVERED
		6. PERFORMING ORG. REPORT NUMBER WT-1677 (EX)
7. AUTHOR(s) J. C. Maloney M. Morgenthau		8. CONTRACT OR GRANT NUMBER(s)
9. PERFORMING ORGANIZATION NAME AND ADDRESS U.S. Army Chemical Warfare Laboratories Army Chemical Center Maryland		10. PROGRAM ELEMENT, PROJECT, TASK AREA & WORK UNIT NUMBERS
11. CONTROLLING OFFICE NAME AND ADDRESS Headquarters Field Command Defense Atomic Support Agency Sandia Base, Albuquerque, New Mexico		12. REPORT DATE August 24, 1960
		13. NUMBER OF PAGES
14. MONITORING AGENCY NAME & ADDRESS (if different from Controlling Office)		15. SECURITY CLASS. (of this report) UNCLASSIFIED
		15a. DECLASSIFICATION/DOWNGRADING SCHEDULE
16. DISTRIBUTION STATEMENT (of this Report) Approved for public release; unlimited distribution.		
17. DISTRIBUTION STATEMENT (of the abstract entered in Block 20, if different from Report)		
18. SUPPLEMENTARY NOTES This report has had the classified information removed and has been republished in unclassified form for public release. This work was performed by Kaman Tempo under contract DNA001-79-C-0455 with the close cooperation of the Classification Management Division of the Defense Nuclear Agency.		
19. KEY WORDS (Continue on reverse side if necessary and identify by block number) Operation HARDTACK Gamma Dose		
20. ABSTRACT (Continue on reverse side if necessary and identify by block number) Project 2.9 participated in Shot Quince and Shot Fig with the following objectives: (1) to document the initial gamma dose versus ground range and (2) to measure the total gamma dose received at a point as a function of time, at distances of military interest, for a fractional-kiloton nuclear surface burst. Project 2.12b participated in Shot Hamilton and Shot Humboldt with the following objectives: (1) to provide gamma-dose measurements in support of the biomedical Project 4.2 and (2) to document the initial gamma dose versus ground range.		

FOREWORD

This report has had classified material removed in order to make the information available on an unclassified, open publication basis, to any interested parties. This effort to declassify this report has been accomplished specifically to support the Department of Defense Nuclear Test Personnel Review (NTPR) Program. The objective is to facilitate studies of the low levels of radiation received by some individuals during the atmospheric nuclear test program by making as much information as possible available to all interested parties.

The material which has been deleted is all currently classified as Restricted Data or Formerly Restricted Data under the provision of the Atomic Energy Act of 1954, (as amended) or is National Security Information.

This report has been reproduced directly from available copies of the original material. The locations from which material has been deleted is generally obvious by the spacings and "holes" in the text. Thus the context of the material deleted is identified to assist the reader in the determination of whether the deleted information is germane to his study.

It is the belief of the individuals who have participated in preparing this report by deleting the classified material and of the Defense Nuclear Agency that the report accurately portrays the contents of the original and that the deleted material is of little or no significance to studies into the amounts or types of radiation received by any individuals during the atmospheric nuclear test program.

FOREWORD

This report presents the final results of two of the projects participating in the military-effect programs of Operation Hardtack. Overall information about this and the other military-effect projects can be obtained from ITR-1660, the "Summary Report of the Commander, Task Unit 3." This technical summary includes: (1) tables listing each detonation with its yield, type, environment, meteorological conditions, etc.; (2) maps showing shot locations; (3) discussions of results by programs; (4) summaries of objectives, procedures, results, etc., for all projects; and (5) a listing of project reports for the military-effect programs.

ABSTRACT

Project 2.9 participated in Shot Quince and Shot Fig with the following objectives: (1) to document the initial gamma dose versus ground range and (2) to measure the total gamma dose received at a point as a function of time, at distances of military interest, for a fractional-kiloton nuclear surface burst.

Project 2.12b participated in Shot Hamilton and Shot Humboldt with the following objectives: (1) to provide gamma-dose measurements in support of the biomedical Project 4.2 and (2) to document the initial gamma dose versus ground range. In addition, secondary objectives of this project were to document residual radiation intensities and to determine the field gamma-decay rate.

These objectives were accomplished by measuring the dose with film badges which were exposed at various ranges and azimuths, observing the dose on the film badges of the incremental-gamma-dose recorders (Emmett devices), and by field surveys with portable instruments.

Project 4.2 was furnished gamma-dose information for their stations.

The following conclusions are based on the results from Shots Fig, Hamilton, and Humboldt and apply to fractional-kiloton-yield devices tested:

1. Initial gamma doses in the 300 to 900 yard range may be extrapolated from TM 23-200 data with confidence, for surface bursts.
2. An air burst will deliver at least twice the initial gamma dose of a surface burst for the same yield, at distances up to 300 yards from detonation. At greater distances the difference between the doses received from the air burst and the surface burst decreases, and the doses become nearly equal to 1,000 yards.
3. Lethal doses (600 r) of initial gamma radiation are received at approximately 150 yards from the point of detonation the 7.8-ton Humboldt low air burst, while the delivery crews, in the open, would receive 15 r of initial gamma radiation at ranges 575 yards respectively.
4. The observed variation of gamma dose with azimuth for the surface burst is probably caused by the contribution of dose from the transient cloud.
5. The residual gamma fields produced by low air bursts detonated on wooden towers are very small, less than 200 yards radius after 15 minutes, for the 10 r/hr isodose line. This field is due to fission-product radiation, probably from contaminated tower materials.
6. The alpha-contamination levels from low air bursts at distances greater than 100 yards are considered to be an insignificant hazard.

PREFACE

Project 2.9 made the initial gamma measurements for the fractional-kiloton detonations at the Eniwetok Proving Ground. Subsequent to the cessation of operations at Eniwetok, Project 2.12b was initiated on short notice to make similar measurements on similar devices at the Nevada Test Site. Since the objectives, operations, and findings of the two projects are so interwoven, it was deemed advisable to prepare a combined report, rather than two similar reports with multiple cross-referencing throughout.

The authors wish to express their appreciation to Edgerton, Germeshausen and Grier, Inc., for the use of their gamma source for calibration of film badges and to G. Carp and R. Larrick, U. S. Army Signal Research and Development Laboratory, for their advice in the operation of the Emmett device and the processing and interpretation of the film badges.

CONTENTS

FOREWORD	4
ABSTRACT	5
PREFACE	6
OBJECTIVES	9
BACKGROUND	9
THEORY	9
OPERATIONS	10
EPG Operations	10
NTS Operations: Film Dosimetry	13
NTS Operations: Field Surveys	15
INSTRUMENTATION	16
Incremental-Gamma-Dose Recorders	16
Film-Badge Station	16
Field-Survey Instrumentation	16
DATA REQUIREMENTS	20
RESULTS	21
Shot Quince	21
Shot Fig	21
Shot Hamilton	21
Shot Humboldt	23
DISCUSSION	24
CONCLUSIONS	28
RECOMMENDATIONS	29
REFERENCES	31
TABLES	
1 Shot Data	11
2 Station Locations, Shots Quince and Fig	11
3 Sensitivity Ranges of Dosimetry Film	20
4 Neutron Sensitivity of Film	20
5 Gamma-Dose Distance Data for Shots Fig, Hamilton, and Humboldt	21
6 Emmett Gamma Doses	24

7	Shot Hamilton Gamma Doses at Project 4.2 Stations	26
8	Shot Hamilton Alpha-Contamination Levels	28
9	Distance from Ground Zero to 10 r/hr Isodose Lines, Shots Hamilton and Humboldt	28
10	Shot Humboldt Gamma Doses at Project 4.2 Station (Test Conditions)	29

FIGURES

1	Location of film-badge stations	12
2	Station layout, Shot Hamilton	13
3	Biomedical foxhole-and-vehicle array	14
4	Station layout, Shot Humboldt	15
5	Cross section of Emmett device	17
6	Emmett device mechanism	17
7	Installation of Emmett device	18
8	Closeup of Emmett device during final installation	18
9	Emmett device as installed	19
10	Film-badge station	19
11	Gamma dose times distance squared versus distance for Shots Fig, Hamilton, and Humboldt (test conditions)	22
12	Initial gamma dose versus distance for Shots Fig, Hamilton, and Humboldt, and prediction for a 1-ton yield	23
13	Ratios of measured initial gamma dose to predicted dose versus distance for Shots Fig, Hamilton, and Humboldt	25

GAMMA DOSE from VERY-LOW-YIELD BURSTS

OBJECTIVES

The objectives of Project 2.9 were: (1) to document the initial gamma dose versus ground range and (2) to measure the total gamma dose received at a point as a function of time, at distances of military interest, for a fractional-kiloton nuclear surface burst.

The primary objectives of Project 2.12b were: (1) to provide gamma-dose measurements in support of the biomedical Project 4.2 and (2) to document the initial gamma dose versus ground range for Shots Hamilton and Humboldt. In addition, secondary objectives of this project were to document residual radiation intensities and to determine the field gamma-decay rate.

BACKGROUND

Very-low-yield weapons are being considered for use in both ground and air warfare. In ground warfare their primary tactical use would be in close-support operations. Here, the initial gamma and neutron radiation is considered to be the controlling criterion for safe employment of such weapons (Reference 1).

Initial-gamma radiation dose has been studied at almost all tests since Operation Sandstone by the exposure of film badges at various distances from ground zero. These measurements have been limited to yields greater than the very-low yields of Shots Fig, Hamilton, and Humboldt. Measurements made at Operation Jangle (Reference 2) and Operation Plumbbob (Reference 3) provide the most appropriate background data for this project. These references indicate that the initial gamma radiation from a surface burst is reduced by 50 percent compared to an equivalent air burst. Therefore, the air burst would have a greater gamma lethality radius than an equivalent surface burst.

Since fractional-kiloton weapons will probably be employed as low air or surface bursts, the likelihood of fallout and neutron-activated soil contamination exists. Furthermore, since the low-yield weapons would be inefficient in terms of fissioning of nuclear materials, the likelihood of alpha contamination exists. Project 2.10 documented the alpha and gamma contamination levels for the surface Shots Quince and Fig (Reference 4), but was not operational for the air-burst Shots Hamilton and Humboldt. Project 2.12b, with little additional effort, assumed these tasks for these events.

THEORY

With any nuclear detonation, various nuclear radiations are emitted during and after the explosion. Since this report deals with the gamma radiation, the phenomena associated with this radiation will be discussed here briefly.

It is convenient to consider the gamma radiation as being divided into two categories, initial and residual. For this project, the initial radiation is arbitrarily taken as that emitted during the first minute after the explosion. This radiation results from many nuclear reactions and effects, of which three predominate (References 5 and 6):

1. Prompt radiation accompanying the fission process, which is emitted during the first few microseconds.
2. Nitrogen-capture photons emitted from the capture of thermal neutrons by nitrogen in

the atmosphere and in the weapon's high explosives. These photons have high energies (5 to 10 Mev) and account for almost all the dose received from a few milliseconds to a quarter of a second. For high-neutron-flux fission weapons (< 20 kt), this dose accounts for 50 percent of the total initial gamma dose at 1,000 yards and 90 percent at 3,000 yards.

3. Fission-product gamma rays emitted from the fireball and cloud. These rays have a mean energy of about 1 Mev and account for the dose received after the first quarter second. This dose drops off rapidly as the fission products decay and the fireball rises.

Reference 7 contains a collation of initial gamma-dose data from many previous operations. By plotting experimental values of dose-per-unit yield times distance squared versus distance for surface bursts of low- and intermediate-yield weapons, it was found that the straight line of best fit is described by the following equation.

$$\frac{DR^2}{Wh_{\text{eff}}} = 1.93 \times 10^9 e^{-\rho R/324} \quad (1)$$

Where: D = initial gamma dose, roentgens
 R = distance from detonation, yards
 W = yield, kt
 h_{eff} = effective hydrodynamic scaling factor = 1 for subkiloton bursts
 ρ = relative air density

The residual nuclear radiation is defined as that emitted after 1 minute following the detonation. This radiation arises from deposited bomb residues (fission products, unfissioned uranium and plutonium, neutron-activated bomb materials) and from activity induced by neutrons captured in various elements present in the earth or in substances in the vicinity of the detonation. In the case of an air burst, the fission products and bomb residues are dispersed widely and usually do not produce a military problem. However, the induced activity in the soil near ground zero may constitute a military problem for early operations in this area.

Induced gamma activity in soil results when neutrons are captured by nuclei of certain soil elements. The resulting products are radioactive isotopes of the original absorbing elements and can be expected to be unstable. These decay to stable isotopes, usually with the emission of a gamma ray. In the case of most soils, the significant elemental constituents that become activated and cause the induced gamma field are aluminum, manganese, and sodium (with half lives of 2.3 minutes, 2.6 hours, and 15 hours, respectively). Project 2.12c investigated soil-induced activity, and a detailed discussion of this phenomenon can be found in the report of that project (Reference 8).

OPERATIONS

Project 2.9 participated in Shots Quince and Fig at Site Yvonne, Eniwetok Proving Ground (EPG). Project 2.12b participated in Shots Hamilton and Humboldt at Frenchman Flat and Area 3, respectively, Nevada Test Site (NTS). Table 1 lists some of the characteristics and conditions of detonation of these shots.

EPG Operations. Stations were placed as follows: (1) thirty-six film-badge stake stations on land, (2) four Emmett devices on land, (3) eight film-badge stations along the Project 2.4a west neutron line on land and water, and (4) seven film-badge stations aloft at Project 2.4a stations, hung vertically from the Project 2.11 balloon.

The location of the film-badge stations on land, water, and the balloon are shown in Figure 1. Station distances and azimuths for all stations are tabulated in Table 2. The station array is far from ideal because of the limited land mass and obstructions, but is the best compromise of available locations with line of sight to ground zero.

The project participated in Shots Quince and Fig with identical instrumentation being used for both events. The dosimeter film badges were installed several days before the shot and recovered at approximately H+24 hours. Film badges were calibrated immediately following

TABLE 1 SHOT DATA

Shot	Burst	Support	Yield	Air Relative		Atmospheric	Relative
	Height			Temp	Humidity		
	ft		tons	C	pct	mb	
Quince	0	Ground					
Fig	0	Ground		30	77	1,007	0.90
Hamilton	50	Wooden Tower	1.17 ± 0.06	15.7	31	891	0.83
Humboldt	25	Wooden Tower	7.8 ± 0.7	7.4	46	885	0.85

TABLE 2 STATION LOCATIONS, SHOTS QUINCE AND FIG

Station Number	Type	Distance	Azimuth	Station Number	Type	Distance	Azimuth
		yds	deg			yds	deg
South Line				West Line			
35	Land	30	143	W-1	Land	30	233
1	Land	90	135	10	Land	86	242
13	Land	99	150	W-2	Land	100	233
14	Land	198	150	11	Land	103	205
36	Land	200	165	W-3	Buoy	247	233
15	Land	293	150	W-4	Buoy	344	233
16	Land	400	147	W-5	Buoy	444	233
17	Land	497	147	W-6	Buoy	603	233
18	Land	596	147	W-7	Buoy	817	233
19	Land	723	145	W-8	Buoy	1,040	232
20	Land	805	145	Balloon Line			
21	Land	873	145	B-1	Balloon	121	165
North Line				B-2	Balloon	133	165
6	Land	100	330	B-3	Balloon	173	165
7	Land	100	315	B-4	Balloon	227	165
8	Land	100	300	B-5	Balloon	283	165
5	Land	105	350	B-6	Balloon	347	165
24	Land	199	330	B-7 *	Balloon	410	165
23	Land	200	315	Emmett Station			
22	Land	200	300	E-1	Emmett	100	324
26	Land	298	319	E-2	Emmett	200	323
25	Land	301	330	E-3	Emmett	200	304
27	Land	401	315	E-4	Emmett	400	322
28	Land	402	329	Miscellaneous Stations			
30	Land	500	328	3	Land	40	61
29	Land	501	315	4	Land	49	16
32	Land	601	329	2	Land	60	85
31	Land	602	315	12	Land	100	180
34	Land	701	330	9	Land	101	270
33	Land	711	315				

* Station destroyed.

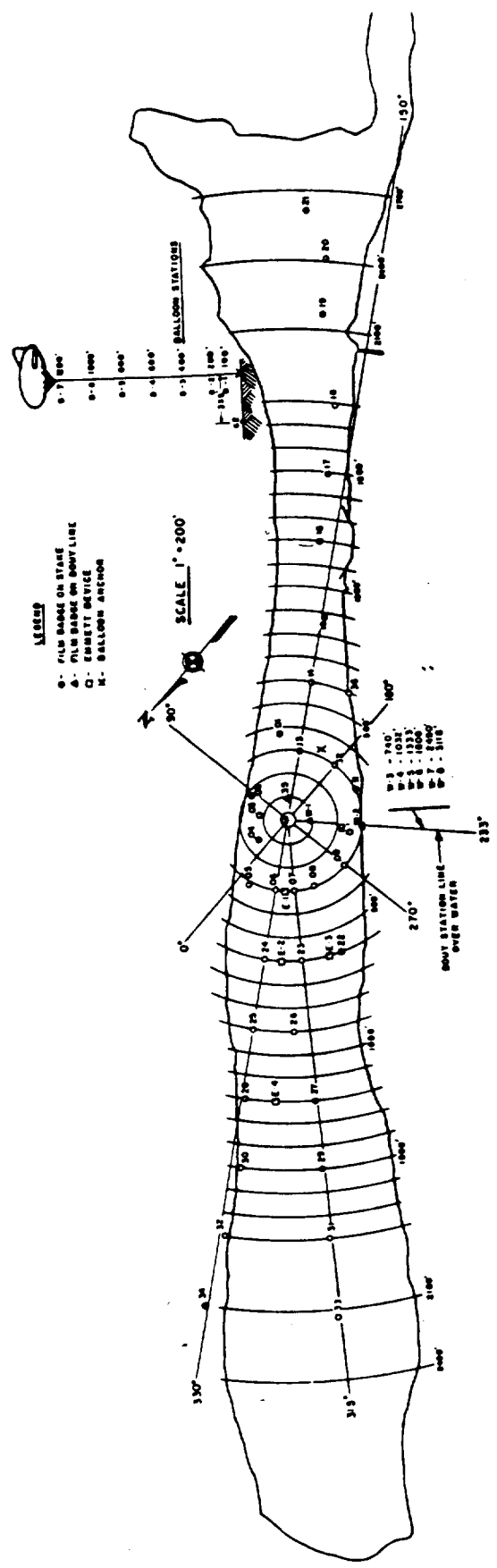

Figure 1 Location of film-badge stations.

Shots Quince and Fig using facilities of Edgerton, Germeshausen and Grier, Inc., (EG&G) at the Eniwetok Proving Ground.

Following recovery, film badges were shipped to the U. S. Army Signal Research and Development Laboratory (ASRDL) for development and interpretation of film density into dose units.

NTS Operations: Film Dosimetry. Shot Hamilton was detonated in Frenchman Flat. Stations were placed as follows: (1) four Emmett devices at distances of 100, 200, 400, and 800 yards

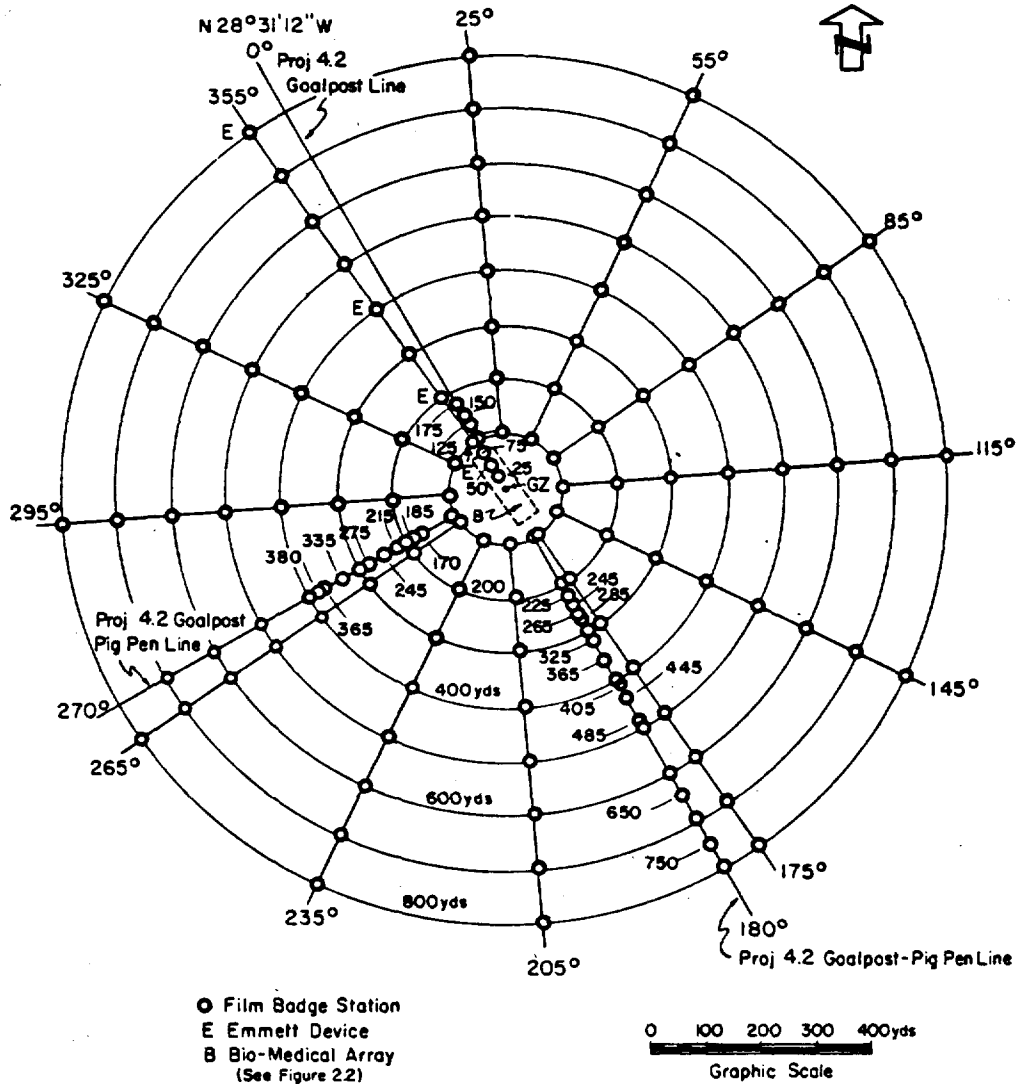

Figure 2 Station layout, Shot Hamilton.

on the 355-degree azimuth; (2) 96 film-badge stakes and alpha-monitoring pads on a polar grid with twelve lines spaced 30 degrees apart and stations spaced at 100-yard intervals from 100 to 800 yards, and (3) 147 film badges for the biomedical station array.

The station plot plan for the polar grid, Emmett stations, and biomedical free-field film-badge locations is shown in Figure 2. The biomedical foxhole-and-vehicle array is shown in Figure 3. All stations, except those in foxholes and vehicles, were mounted on quick-recovery racks ("goal posts") or fastened to pig-pen fences and had a line of sight to ground zero.

Film dosimeters were installed several days before the shot and removed at H+24 hours.

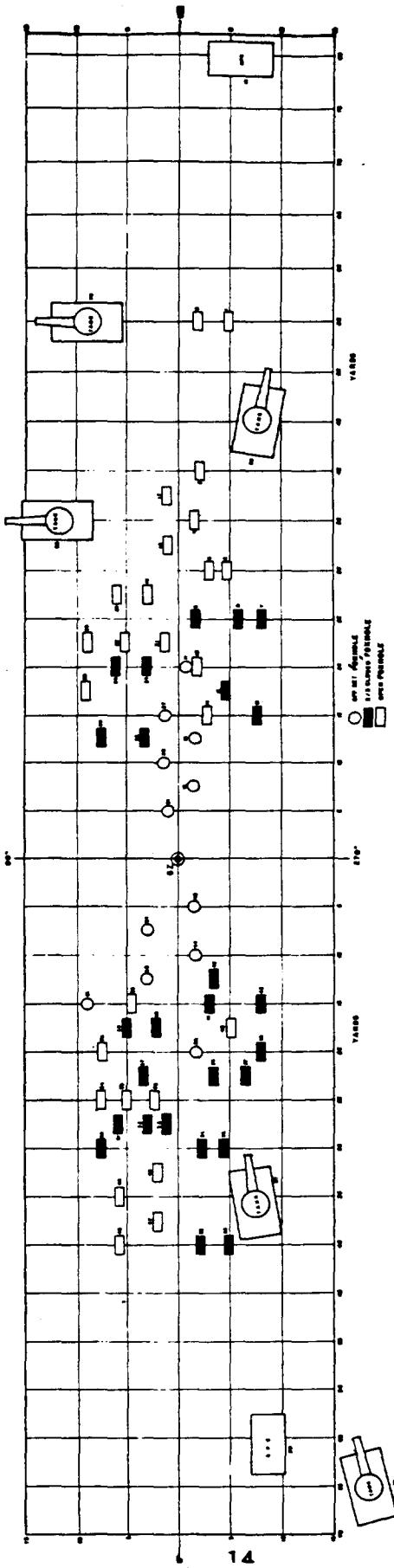

Figure 3 Biomedical foxhole-and-vehicle array.

Calibration of film commenced immediately following the shot, using facilities of EG&G at Las Vegas, Nevada. Film badges were sent to ASRDL, Fort Monmouth, New Jersey, for developing and interpretation of film density into dose units.

Shot Humboldt was planned for the same ground zero as that of Shot Hamilton. The Emmett devices and stake stations in Frenchman Flat were instrumented. However, on D-1, Shot Humboldt was moved to Area 3; the project participation, therefore, was severely limited. Project 2.12b provided Project 4.2 with 28 film badges, the locations of which are shown in Figure 4. The film dosimeters were installed by Projects 2.12a and 4.2 several hours before the shot and recovered during early-entry postshot operations of these projects. Calibration, processing and read-out were accomplished in the same manner as for Shot Hamilton.

NTS Operations: Field Surveys. Personnel of the U. S. Army Chemical Corps Training Command, Fort McClellan, Alabama, performed gamma field surveys to (1) delineate the 10

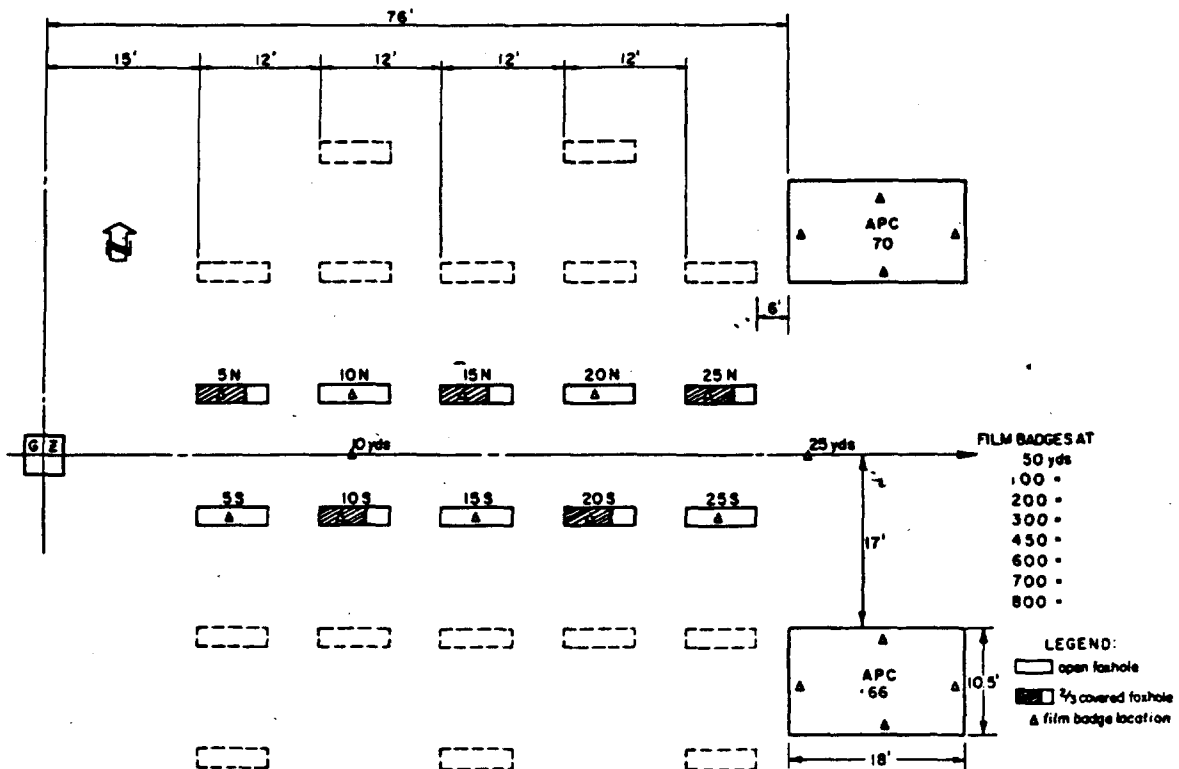

Figure 4 Station layout, Shot Humboldt.

r/hr contour at H+15 minutes, (2) to detect any isolated 10 r/hr hot spots at H+15 minutes, and (3) to determine field decay rates.

Immediately following the passage of the blast wave from Shot Hamilton, four two-man monitoring teams moved into the area by jeep from the forward manned station. One team surveyed the general outlying area around ground zero with special reference to the ground in the direction of observed cloud travel. The other three teams began immediate surveys on four each of the twelve film-badge stake lines. These teams recorded the location of the 10 r/hr point on each stake line by dropping markers and then measuring the dose rate at each stake outside of the 10 r/hr line. This procedure was repeated on subsequent surveys, readings also being taken at each point where 10 r/hr had been noted previously.

For Shot Humboldt, the late shifting of ground zero from Frenchman Flat to Area 3 necessitated some changes. Time was available only to install four lines of stakes, one in each major compass direction, at 200-yard intervals to 800 yards.

Immediately following the passage of the blast wave, one team moved into the area, marked the 10 r/hr point on the east line, and measured the dose rate at each stake on that line outside of this point. At 15 minutes following the shot (H+15 minutes), four additional teams made similar surveys on all four lines and the other team made a general survey as for Shot Hamilton. Additional surveys were made up to H+6.5 hours when the area was evacuated for another shot.

A survey for alpha contamination was made after Hamilton D+1 day at the 96 alpha-monitoring pads adjacent to the film-badge stake stations. Operational conditions, such as late shifting of ground zero and time limitations before and after the shot, precluded any alpha surveys for Shot Humboldt.

INSTRUMENTATION

Incremental-Gamma-Dose Recorders. The incremental-gamma-dose recorder used was a modified Emmett device as employed by Project 2.5 during Operation Plumbbob. This device is essentially a conveyor belt of film badges, each of which is exposed in turn from an underground shield and returned thereto. A typical station cross-section is shown in Figure 5, and a line drawing of the mechanism is presented as Figure 6. A complete description of the Emmett device is given in Reference 3.

Since the Emmett device does not have a fast-enough time resolution to differentiate the various initial gamma pulses from very-low-yield bursts, it was decided to change the traveling speed of the film badges in order that each badge would be exposed for 1 minute. (The device so modified ran for 20 minutes and could provide fallout-arrival data or early-decay data.) By spacing the film badges so that some were in the probe above ground at zero time, it was possible to obtain total gamma doses during the first 3, 15, and 30 seconds.

The speed of the Emmett device, as modified by this project, was sensitive to battery voltage. Consequently, freshly charged batteries were employed, and the speed was set by adjusting a resistance in series with the motor just before the assembly was lowered into the ground. The speed setting was verified by timing the drive-sprocket revolutions with a stop watch. Dry runs over the entire cycle of operation showed that the speed did not vary by more than ± 5 percent.

Figures 7, 8, and 9 are photographs of steps in the installation of an Emmett station. In Figure 7, the instrument rack complete with film probe is lowered into the underground shield. In Figure 8, the rack and probe are in place along with sand-bag shielding. The top of the probe was screwed in place after the 30-second-exposure film badges were checked for proper position at the top of the probe. Figure 9 shows the completely installed station, with the blast shield in place and the timing wire connected. (The smaller cylindrical tube was originally used during Operation Plumbbob to protect an ionization chamber. It was not used by this project.)

Film-Badge Station. The film badges were placed in National Bureau of Standards (NBS) holders, which were inserted, in turn, in plastic cigarette cases for dust and moisture protection. A discussion of the NBS holder is contained in Reference 9. All film badges within 300 yards from ground zero were also placed inside of electrical "condulets" or pipe nipples for blast, missile, and thermal protection.

A condulet is a small, weather-proof, iron, electrical-junction box. The model used by this project incorporated female pipe threads to facilitate fastening to iron-pipe stakes. (The condulets were previously treated to remove cadmium plating and so minimize neutron-capture photons.)

The film packs were mounted on top of 3-foot-long pipes driven into the ground. For Shot Hamilton, several stations were extended to 6 feet elevation to clear a shadow-shielded area behind a dike to the east of ground zero. Figure 10 illustrates a typical station.

Table 3 lists the ranges covered by the individual films in the film badge.

Field-Survey Instrumentation. The field-survey teams used the AN-PDR/39 for gamma readings and the Eberline PAC-3G alpha survey instrument for alpha readings. These instruments are described in References 11 and 4 respectively.

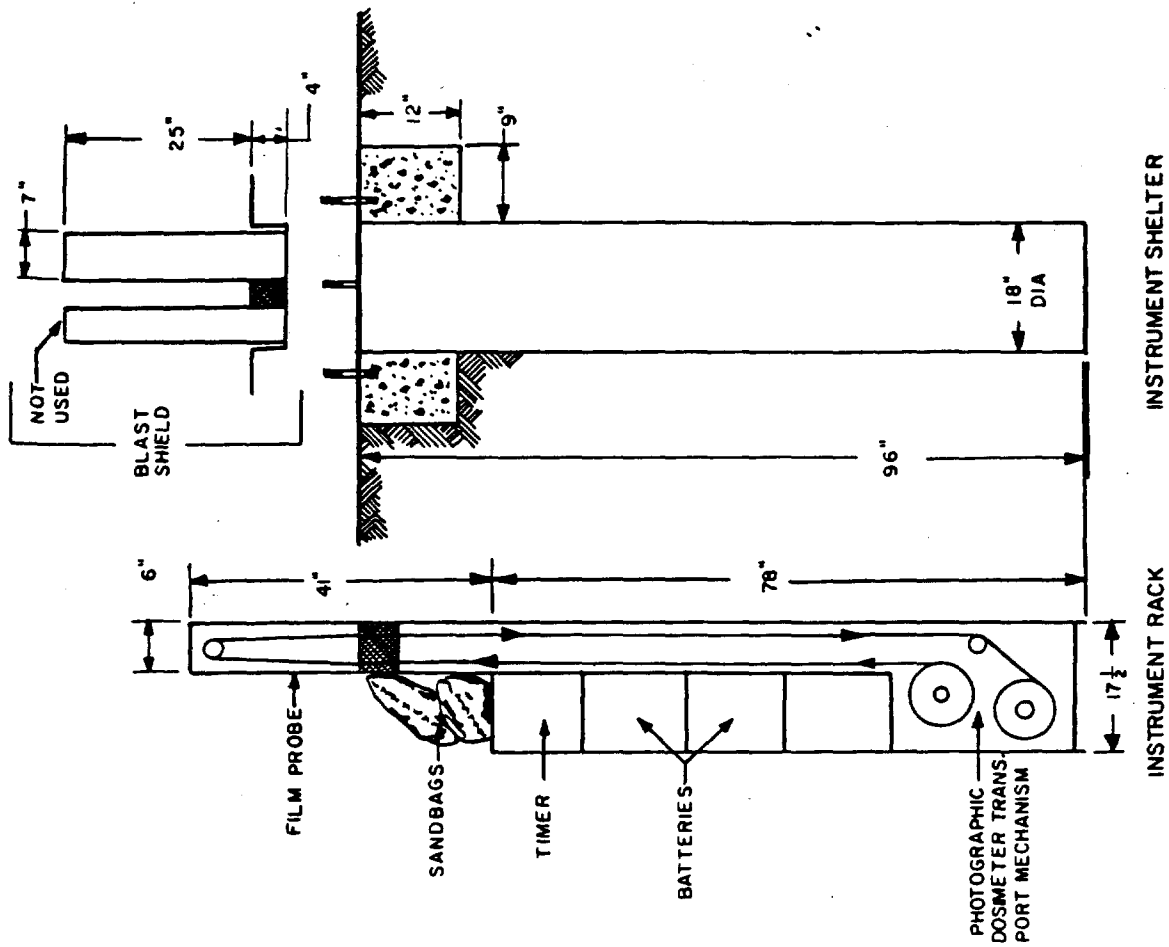

Figure 5 Cross section of Emmett device.

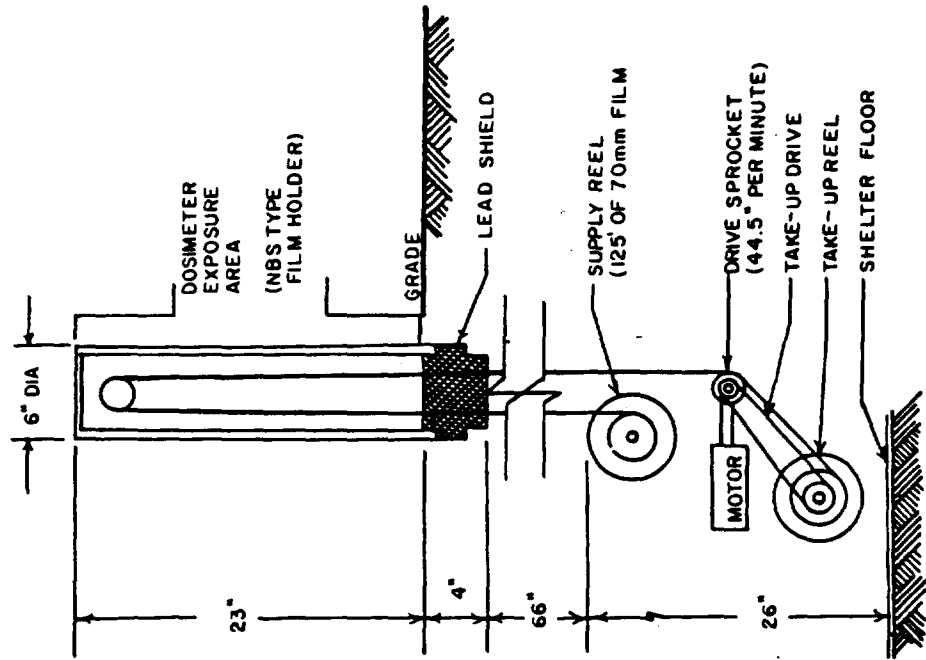

Figure 6 Emmett device mechanism.

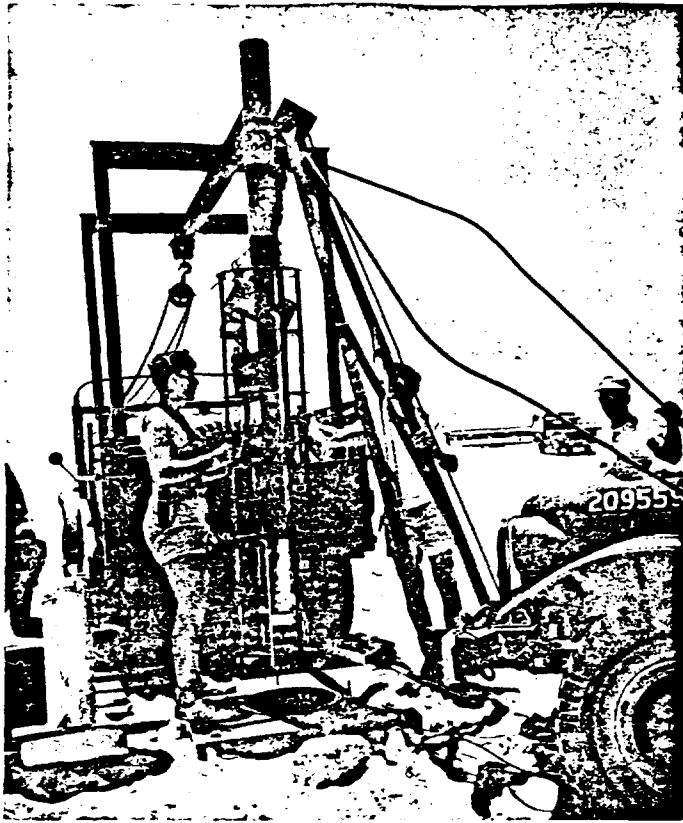

Figure 7 Installation of Emmett device.



Figure 8 Closeup of Emmett device during final installation.

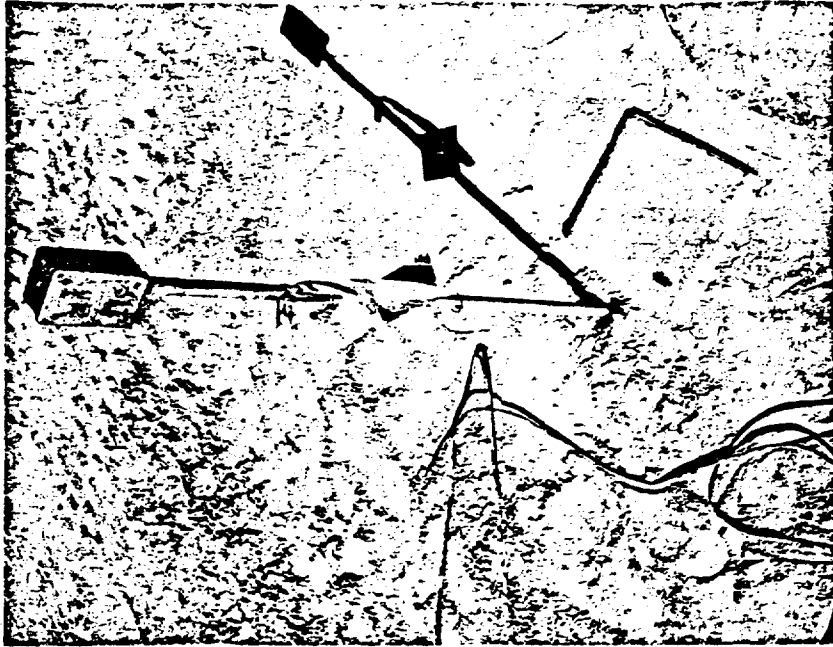

Figure 10 Film-badge station.

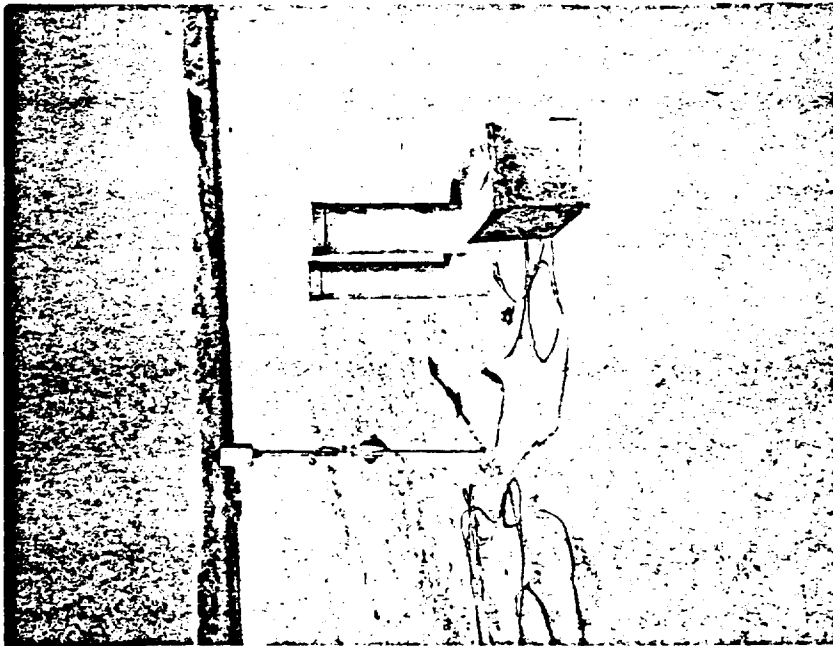

Figure 9 Emmett device as installed.

DATA REQUIREMENTS

To accomplish project objectives, initial gamma measurements were required versus distance from ground zero for each of three fractional-kiloton detonations. It was necessary that the extent and magnitude of residual-gamma fields be known so that data corrections could be made. Residual-gamma readings were obtained from the early field surveys of Projects 2.10 and 2.12b and the Emmett devices of Project 2.9.

Total gamma doses were measured with film badges. The film dosimetry used had an accuracy of ± 20 percent, not considering residual radiation, station shielding, and neutron effects

TABLE 3 SENSITIVITY RANGES OF DOSIMETRY FILM

Packet Type	Emulsion	Range
	number	r
DuPont 553	502	0.3 to 5
DuPont 553	510	3 to 50
DuPont 553	606	25 to 2,500
Eastman Special Order	548-0 DC	2,500 to 50,000

on the film (Reference 9). It has been estimated that these effects, if uncorrected, could reduce the accuracy of the film dosimetry to ± 50 percent (Reference 9).

Film emulsions are sensitive to capture-gamma photons and to thermal and fast neutrons. The capture-gamma photons are generated by thermal neutrons absorbed in the walls of the film-protection container. Table 4 lists data from Reference 5 on the film sensitivity to neutrons.

The subject of neutron-capture photons generated in a steel shield has been treated in Refer-

TABLE 4 NEUTRON SENSITIVITY OF FILM

Packet Type	Emulsion	Low-Energy (Gold)	High-Energy
		Neutrons	Neutron Dose
	number	$10^{-3}(\text{n/cm}^2)/\text{r}$	n rep dose/r
DuPont 553	606	3.4 ± 1.8	28 ± 17
DuPont 553	502	3.2 ± 1.7	26 ± 15
DuPont 553	510	2.3 ± 1.4	19 ± 12
Eastman Special Order	548-0 DC	4.7 ± 1.9	20 ± 12

ence 10. For this steel, the capture photons can be estimated from the following equation:

$$P = \frac{2 K n \sigma I_{th}^0}{\mu - N \Sigma} \left(e^{-N \Sigma x} - e^{-\mu x} \right) \quad (2)$$

Where: P = generated dose, in roentgens
 K = conversion factor from gamma flux to gamma dose, 2.39×10^3 r/(photon/cm²)
 x = thickness of shield, cm
 nσ = macroscopic activation cross section, per cm
 μ = linear absorption coefficient, per cm
 NΣ = macroscopic removal cross section, per cm
 I_{th}⁰ = incident thermal neutron flux, neutrons/cm²

The neutron effects all increase the indicated dose as read on the films; whereas absorption of gamma rays by the shield decreases the indicated dose, resulting in some self-cancellation of effects.

RESULTS

Project 2.9 participated in Shots Quince and Fig, which were surface detonations of fractional-kiloton nuclear devices on Site Yvonne at EPG. Project 2.12b participated in Shots Hamilton and Humboldt, which were tower detonations of similar devices at the Nevada Test Site.

Shot Quince.

Shot Hamilton. Participation was successful in Shot Hamilton, a 1.17-ton shot on a 50-foot wooden tower. All Emmett devices functioned properly and all film-badge stations were recovered.

Film calibration, station recovery, field surveying, and film processing proceeded according to plan. The same calibration source used for Shot Fig was available for this event. However, an accident during film development resulted in the loss of data from the project film-badge stake station and Emmett devices. A defective safe light in the dark room fogged the

films to the extent that interpretation of density was impossible. However, all open-field stations of Project 4.2 in three directions were instrumented by Project 2.12b. Each of the stations had a direct line of sight to ground zero and provided enough data points to meet the objective of documenting initial gamma dose versus distance.

All open-field data were corrected the same as for Shot Fig and appear in Figure 11. The doses in vehicles, open foxholes, and some offset foxholes were corrected for neutron and

station-shielding effects. However, most offset foxholes and all $\frac{2}{3}$ -covered foxholes were not adequately instrumented for neutron measurements, and the data had to be left in the raw form.

Gamma dose versus distance, corrected to a relative air density of 0.9, is tabulated in Table 5 and plotted in Figure 12. Gamma doses at all Project 4.2 stations are tabulated in Table 7 for the test-condition relative air density of 0.83. Alpha-survey data is tabulated in Table 8.

The 10 r/hr isodose lines as determined from field surveys were irregular star-shaped curves inclosing very small areas as shown in Table 9. No evidence of a downwind highly radio-

active (hot) line was found. The minimum and maximum distances of these curves from ground zero at various times are tabulated in Table 9. The gamma decay followed the usual fission-product decay law with an average exponent of -1.1 from $H+10$ minutes to $H+1$ day. Reference 13, the report of the field-survey group, contains a multitude of data sheets, curves, and iso-dose plots of the data.

Shot Humboldt. Participation was successful in Shot Humboldt, a 7.8-ton shot on a 25-foot wooden tower. Since this event was moved at the last minute to a different ground zero than

planned, effort was limited to instrumenting Project 4.2 stations with film badges plus a few hasty gamma-field surveys.

The film badges were recovered within a few minutes after detonation by a coordinated effort of this project and Projects 2.12a and 4.2. Instrumentation, and the two APC vehicles, were dragged out of the ground-zero area by pulling cables.

The open-field data were corrected the same as for Shot Fig. See Figure 11. The doses in

vehicles and foxholes were corrected for neutron and station-shielding effects.

Gamma dose versus distance, corrected to a relative air density of 0.9, is tabulated in Table 5 and plotted in Figure 12. Gamma doses at all Project 4.2 stations are tabulated in Table 10 for the test-condition relative air density of 0.85.

The 10 r/hr isodose lines, as determined from field surveys, were roughly circular with radii of 200 yards or less. There was no evidence of a downwind hot line. The minimum and maximum distances that these curves extended from ground zero at various times are tabulated in Table 9. Since field surveying had to be concluded by H+7 hours, only limited experimental data was obtained on field decay. These data only suggest that the contamination decayed according to the fission-product law. Reference 13 contains all survey data obtained for this event.

DISCUSSION

Although the film badges were in all cases exposed for more than 1 minute, it is felt that the data in Figure 12 represents initial gamma dose or a combination of initial dose and dose caused by the passage of the low cloud. Some close-in stations for all three events were affected by

TABLE 6 EMMETT GAMMA DOSES

Time Interval	Dose at Station			
	100 yd, 325 deg	200 yd, 325 deg	200 yd, 305 deg	400 yd, 325 deg
min	r	r	r	r
0 to 0.05	3,200	390	360	19
0 to 0.25	3,500	280	390	79
0 to 1/2	4,100	700	260	54
0 to 1	2,700	450	*	11
1/2 to 1 1/2	580	89	110	0
1 to 2	120	5.8	5.3	0
1 1/2 to 2 1/2	14	0	1.8	0
2 to 3	3.8	0	0	0
2 1/2 to 3 1/2	3.6	0	0	0
3 to 4	1.3	0	0	0
3 1/2 to 4 1/2	2.9	0	0	0
4 to 5	1.5	0	0	0
4 1/2 to 5 1/2	1.4	0	0	0
5 to 6	0	0	0	0

* Defective film badge

residual fields.

the Hamilton and Humboldt low air bursts, the values beyond 100 yards approximated straight lines. The best least-squares fit for these lines was calculated and extrapolated to 100 and 1,000 yards.

the open-field results of Shots Hamilton and Humboldt were adjusted to a 1-ton yield for comparative purposes. Predicted gamma doses were calculated from Equation 1 for a 1-ton yield. Gamma

TABLE 7 SHOT HAMILTON GAMMA DOSES AT PROJECT 4.2 STATIONS

Relative air density = 0.83

Station	yd		r		Station	yd		r	
	Slant Distance	Corrected Dose	Uncorrected Dose	r		Slant Distance	Corrected Dose	Uncorrected Dose	r
Doses in the Open, South Line									
100 S	101.3	350			300 W	300	22		
200 S	200	67			X	305	21		
I	225	49			XII	335	16		
II	245	39			XIV	365	12		
III	265	32			XV	380	11		
IV	285	26			400 W	400	9.4		
300 S	300	22			500 W	500	4.5		
VI	325	18			600 W	600	2.3		
VIII	365	12			700 W	700	1.3		
400 S	400	9.4			Doses in the Open, North Line				
X	405	9.0			25 N	30.2	~1,800		
XII	445	6.7			50 N	52.8	1,700		
XIV	485	5.0			75 N	76.9	540		
500 S	500	4.5			100 N	101.3	350		
XV	505	4.3			125 N	126	210		
600 S	600	2.3			150 N	150	140		
600 Pen	600	2.3			175 N	175	94		
650 S	650	1.7			Doses in Vehicles				
650 Pen	650	1.7			T 67 NW	39.6	430		
700 S	700	1.3			APC 66 NW	62.9	715		
700 Pen	700	1.3			T 65 NW	70.1	300		
750 S	750	0.96			T 68 SE	40.8	720		
750 Pen	750	0.96			T 69 SW	48.7	370		
800 S	800	0.73			T 70 SE	58.4	500		
800 Pen	800	0.73			APC 71 SW	82.0	390		
Doses in the Open, West Line									
100 W	101.3	350			Doses in Open Foxholes				
I	170	101			14 SW	22.9	~2,300		
II	185	82			62 NE	23.0	~1,800		
200 W	200	67			40 NW	24.9	1,750		
III	200	67			26 SE	25.6	1,800		
IV	215	55			58 NE	27.3	1,050		
VI	245	39			22 SE	28.7	710		
VIII	275	28			10 SW	26.4	*		
					23 SE	29.4	410		
					21 SE	28.3	*		

TABLE 7 CONTINUED

Station	Slant Distance yd	Corrected Dose		Uncorrected Dose		Station	Slant Distance yd	Corrected Dose		Uncorrected Dose	
		r	f	r	f			r	f	r	f
54 NE	31.2		460			29 SE	22.4				750
55 NE	30.6		420			28 SE	21.3				900
56 NE	30.3		460			43 NW	21.3				900
19 SE	32.4		220			41 NW	22.9				1,100
20 SE	32.9		680			42 NW	24.0				640
5 SW	34.8		160			13 SW	23.9				530
6 SW	34.6		240			59 NE	24.9				680
18 SE	36.7		570			60 NE	24.5				590
49 NE	36.8		230			12 SW	24.7				580
46 NE	39.4		340			39 NW	27.3				*
4 SW	39.0		300			24 SE	26.4				530
17 SE	41.1		350			25 SE	26.9				470
47 NE	41.2		290			36 NW	28.4				530
46 NE	43.9		430			37 NW	29.1				500
3 SW	43.5		430			57 NE	28.4				*
1 SW	57.8		280			7 SW	31.3				400
2 SW	57.7		290								
Doses in Offset Foxholes											
64 NE	18.8		69			8 SW	30.8				460
30 SE	19.8		68			9 SW	30.3				420
63 NE	21.3		*			51 NE	32.8				480
27 SE	22.8		16			52 NE	32.4				450
Uncorrected Doses in Offset Foxholes											
45 NW	17.7				200	53 NE	32.2				480
16 SW	18.7				70	34 NW	34.6				400
44 NW	19.8				*	35 NW	34.7				450
61 NE	24.4				130	50 NE	35.3				390
38 NW	26.4				60	32 NW	43.5				230
11 SW	26.3				54	33 NW	43.7				240
31 SE	17.6				*						
15 SW	21.2				*						

* These film badges were either lost or grossly inconsistent.

twice the dose of the surface burst. At greater distances this dose differential decreased until the doses became very nearly equal at 1,000 yards.

The residual fields in the Hamilton and Humboldt ground-zero areas were much lower than expected as the yields of these devices were much lower than expected. In both cases the contamination was apparently fission products from contaminated tower materials. No elongated fallout pattern was observed although one survey team for each event hunted downwind fallout. The alpha-contamination levels of Shot Hamilton, at 100 yards or more from ground zero, were below $120 \mu\text{g}/\text{m}^2$ which is considered an insignificant hazard. The Hamilton ground-zero area

TABLE 8 SHOT HAMILTON ALPHA-CONTAMINATION LEVELS, $\mu\text{g}/\text{m}^2$

Slant Distance yd	Alpha Contamination at Azimuths Shown, deg											
	25	55	85	115	145	175	205	235	265	295	325	355
100	62.4	116.6	15.0	2.2	1.8	1.9	72.4	2.6	23.0	24.0	27.4	66.7
200	20.5	112.0	1.6	0.5	0.8	0.9	0.9	6.5	19.5	0.4	0.9	0.7
300	2.4	91.4	1.4	0.4	0.02	0	0	1.6	2.9	1.8	1.6	1.6
400	0.9	30.9	0.5	0	—	—	0	1.9	3.6	1.0	1.1	0.5
500	2.4	29.2	0.4	—	—	—	0	2.5	3.8	1.1	1.1	0.9
600	1.5	9.1	—	—	—	—	0.3	3.8	7.9	0.5	0.6	0.6
700	1.3	1.4	—	—	—	—	0	2.1	2.6	—	0.9	0.6
800	1.7	4.1	—	—	—	—	0	1.4	3.1	—	—	—

was visually observed to be strewn with tower debris, paraffin, etc. Since this debris probably became embedded with fission products and alpha emitters, the absence of this debris (as would be the case for a detonation in free air) would cause even lower ground-zero contamination levels.

Since the Emmett devices were not in the fallout area for Shot Fig, no data were obtained on fallout arrival or decay. The activity detected for a few minutes at the closest stations was probably crater shine.

CONCLUSIONS

The following conclusions are based on the results from Shots Hamilton, and Humboldt

TABLE 9 DISTANCE FROM GROUND ZERO TO 10 R/HR ISODOSE LINES, SHOTS HAMILTON AND HUMBOLDT

Time After Detonation min	Shot Hamilton		Shot Humboldt	
	Minimum	Maximum	Minimum	Maximum
	yd	yd	yd	yd
10	40	90	140	205
15	30	75	120	180
30	15	65	85	150
60	5	55	30	100

and apply to fractional-kiloton-yield devices tested.

1. Initial gamma doses in the 300- to 900-yard range may be extrapolated from TM 23-200 data with confidence for surface bursts.

2. For the same yield at distances up to 300 yards from detonation, an air burst will deliver at least twice the initial gamma dose of a surface burst. At greater distances the difference between the doses received from the air burst and the surface burst decreases, and the doses become nearly equal at 1,000 yards.

3. Lethal doses (600 r) of initial gamma radiation are received at approximately 150 yards from the point of detonation

a 7.8-ton low air burst

(Shot Humboldt), while the delivery crews, in the open, would receive 15 r of initial gamma radiation at ranges of 575 yards, respectively.

4. The observed variation of gamma dose with azimuth for the surface burst is probably caused by the contribution of dose from the transient cloud.

5. The residual-gamma fields produced by low air bursts detonated on wooden towers are very small (less than 200 yards radius at H+15 minutes) for the 10 r/hr isodose line. This

TABLE 10 SHOT HUMBOLDT GAMMA DOSES AT PROJECT 4.2 STATION (TEST CONDITIONS)

Station	Slant Distance yd	Corrected Dose r
Doses in the Open, East Line		
25	26.4	19,000
50	50.7	5,500
100	100	2,800
200	200	500
300	300	160
450	450	41
600	600	14
700	700	7.5
800	800	4.1
Doses in Foxholes		
5 S	10.5	14,500
10 N	13.3	16,000
15 S	16.9	*
20 N	20.1	6,000
25 S	23.7	5,900
5 N	10.5	13,600
10 S	13.3	13,200
15 N	16.9	3,900
20 S	20.1	6,400
25 N	23.7	1,500
Doses in Vehicles		
APC 66	30.5	
Front		19,000
Middle		11,500
Middle		9,800
Rear		10,000
APC 70	30.5	
Front		18,200
Middle		13,200
Middle		12,200
Rear		10,400

* Film badge defective.

field is due to fission-product radiation, probably from contaminated tower materials.

6. The alpha-contamination levels from low air bursts at distances greater than 100 yards are considered to be an insignificant hazard.

RECOMMENDATIONS

Further experimentation on fractional-kiloton devices is desirable because the small number

of tests performed were accomplished under far-from-ideal testing conditions.

1. The initial gamma radiation from a surface burst should be measured over a 2π area instead of over small, narrow sectors, and should include dose-versus-time measurements.

2. The above measurements should be repeated for air bursts, using balloons instead of wooden towers for support of the device, in order to avoid interference from the residual radioactivity caused by tower material.

3. Laboratory experiments should be performed to determine more accurately the effects of neutrons on film emulsions and the contribution of the gamma photons from thermal-neutron capture in the walls of the protective shields.

REFERENCES

1. Staff Study; "Estimated Weapon Effects of Fractional KT Nuclear Weapons"; November 1957; U. S. Army Engineer Research and Development Laboratories, Fort Belvoir, Virginia; Secret Restricted Data.
2. L. Costrell; "Gamma Radiation as a Function of Time and Distance"; Project 2.1a, Operation Jangle, WT-329, April 1952; National Bureau of Standards, Washington, D. C.; Secret Restricted Data.
3. G. Carp and others; "Initial Gamma Radiation Intensity and Neutron-Induced Gamma Radiation of NTS Soil"; Project 2.5, Operation Plumbbob, ITR-1414, November 1957; U. S. Army Signal Engineering Laboratories, Fort Monmouth, New Jersey; Secret Restricted Data.
4. M. Morgenthau and M. Schumchyk; "Residual Radiation from a Very-Low-Yield Burst"; Project 2.10, Operation Hardtack, ITR-1678, November 1958; U. S. Army Chemical Warfare Laboratories, Army Chemical Center, Maryland; Secret Restricted Data.
5. E. N. York; "Initial Nuclear Radiation from Low Yield Fission Weapons"; AFSWC-TN-56-14, December 1956; Air Force Special Weapons Center, Kirtland Air Force Base, New Mexico; Secret Restricted Data.
6. D. C. Borg and C. Eisenhauer; "Spectrum and Attenuation of Initial Gamma Radiation from Nuclear Weapons"; AFSWP-502B, January 1955; Armed Forces Special Weapons Project, Washington 25, D. C.; Secret Restricted Data.
7. "The Nuclear Radiation Handbook"; AFSWP-1100, March 1957; Armed Forces Special Weapons Project, Washington 25, D. C.; Secret Restricted Data.
8. E. F. Wilsey and others; "Soil Activation by Neutrons from a Very-Low-Yield Burst"; Project 2.12c, Operation Hardtack, WT-1680; U. S. Army Chemical Warfare Laboratories, Army Chemical Center, Maryland; Secret Restricted Data.
9. P. Brown and others; "Gamma Exposure versus Distance"; Project 2.1, Operation Redwing, WT-1310, February 1960; U. S. Army Signal Engineering Laboratories, Fort Monmouth, New Jersey; Secret Restricted Data.
10. R. C. Tompkins and others; "Attenuation of Gamma and Neutron Radiation by Armor, Soil, and Structures"; Project 2.4, Operation Plumbbob, WT-1413, draft manuscript; U. S. Army Chemical Warfare Laboratories, Army Chemical Center, Maryland; Secret Restricted Data.
11. Radiac Training Sets AN/PDR-T1-AN/PDR-39; TM 11-5514, May 1951, with addendum October 1952; Department of the Army, Washington, D. C.; Unclassified.
12. "Capabilities of Atomic Weapons"; TM 23-200, Revised Edition, November 1957; Armed Forces Special Weapons Project, Washington 25, D. C.; Confidential.
13. "Radiation Effect Caused by the Explosion of a Davy Crockett Device"; Project No. CMLCD 59T22, December 1958; U. S. Army Chemical Corps School, Fort McClellan, Alabama; Confidential.