

# OPERATION HARDTACK

410978

## Project 2.13

### Gamma Radiation and Induced Activity From Very-Low-Yield Bursts

April-October 1958

Headquarters Field Command  
Defense Atomic Support Agency  
Sandia Base, Albuquerque, New Mexico

October 28, 1960

#### NOTICE

This is an extract of WT-1681, which  
remains classified SECRET/RESTRICTED  
DATA as of this date.

Extract version prepared for:

Director  
DEFENSE NUCLEAR AGENCY  
Washington, D.C. 20305

1 OCTOBER 1983

Approved for public release;  
distribution unlimited.

REPORT DOCUMENTATION PAGE		READ INSTRUCTIONS BEFORE COMPLETING FORM
1. REPORT NUMBER WT-1681 (EX)	2. GOVT ACCESSION NO.	3. RECIPIENT'S CATALOG NUMBER
4. TITLE (and Subtitle) Operation HARDTACK - Project 2.13 Gamma Radiation and Induced Activity From Very-Low-Yield Bursts		5. TYPE OF REPORT & PERIOD COVERED
		6. PERFORMING ORG. REPORT NUMBER WT-1681 (EX)
7. AUTHOR(s) D. R. Griesmer                      P. N. Dean Z. G. Burson T. P. Baker		8. CONTRACT OR GRANT NUMBER(s)
9. PERFORMING ORGANIZATION NAME AND ADDRESS Air Force Special Weapons Center Kirtland Air Force Base, New Mexico		10. PROGRAM ELEMENT, PROJECT, TASK AREA & WORK UNIT NUMBERS
11. CONTROLLING OFFICE NAME AND ADDRESS Headquarters Field Command Defense Atomic Support Agency Sandia Base, Albuquerque, New Mexico		12. REPORT DATE October 28, 1960
		13. NUMBER OF PAGES
14. MONITORING AGENCY NAME & ADDRESS (if different from Controlling Office)		15. SECURITY CLASS. (of this report)  UNCLASSIFIED
		15a. DECLASSIFICATION/DOWNGRADING SCHEDULE
16. DISTRIBUTION STATEMENT (of this Report) Approved for public release; unlimited distribution.		
17. DISTRIBUTION STATEMENT (of the abstract entered in Block 20, if different from Report)		
18. SUPPLEMENTARY NOTES This report has had the classified information removed and has been republished in unclassified form for public release. This work was performed by Kaman Tempo under contract DNA001-79-C-0455 with the close cooperation of the Classification Management Division of the Defense Nuclear Agency.		
19. KEY WORDS (Continue on reverse side if necessary and identify by block number) Operation HARDTACK Gamma Radiation		
20. ABSTRACT (Continue on reverse side if necessary and identify by block number) The principal objectives were to measure: (1) initial-gamma dose rate, (2) total initial-gamma dose, (3) total neutron dose in low dose regions, and (4) rate of induced activity decay in soil, all for very-low-yield nuclear bursts. A secondary objective was to field-test a prototype of the standard Air Force fallout detector (MG-3).		

## FOREWORD

This report has had classified material removed in order to make the information available on an unclassified, open publication basis, to any interested parties. This effort to declassify this report has been accomplished specifically to support the Department of Defense Nuclear Test Personnel Review (NTPR) Program. The objective is to facilitate studies of the low levels of radiation received by some individuals during the atmospheric nuclear test program by making as much information as possible available to all interested parties.

The material which has been deleted is all currently classified as Restricted Data or Formerly Restricted Data under the provision of the Atomic Energy Act of 1954, (as amended) or is National Security Information.

This report has been reproduced directly from available copies of the original material. The locations from which material has been deleted is generally obvious by the spacings and "holes" in the text. Thus the context of the material deleted is identified to assist the reader in the determination of whether the deleted information is germane to his study.

It is the belief of the individuals who have participated in preparing this report by deleting the classified material and of the Defense Nuclear Agency that the report accurately portrays the contents of the original and that the deleted material is of little or no significance to studies into the amounts or types of radiation received by any individuals during the atmospheric nuclear test program.

## *FOREWORD*

This report presents the final results of one of the projects participating in the military-effects programs of Operation Hardtack. Overall information about this and the other military-effects projects can be obtained from ITR-1660, the "Summary Report of the Commander, Task Unit 3." This technical summary includes: (1) tables listing each detonation with its yield, type, environment, meteorological conditions, etc.; (2) maps showing shot locations; (3) discussion of results by programs; (4) summaries of objectives, procedures, results, etc., for all projects; and (5) a listing of project reports for the military-effects programs.

## ABSTRACT

The principal objectives were to measure: (1) initial-gamma dose rate, (2) total initial-gamma dose, (3) total neutron dose in low dose regions, and (4) rate of induced activity decay in soil, all for very-low-yield nuclear bursts. A secondary objective was to field-test a prototype of the standard Air Force fallout detector (MG-3).

Much of the effectiveness in the delivery of air-to-air weapons depends on the range at which they can be safely delivered. Radiation measurements are necessary to substantiate existing methods of prediction or to form the basis for necessary revisions.

The nuclear yield for Shot Hamilton was about one twentieth of that predicted; therefore, optimum utilization of the instrumentation was not obtained.

Results of initial-gamma dose rate versus time from two locations, as determined by Kaiser electronic automatic-dose-rate instruments, are presented graphically. The existing theoretical method is apparently valid for weapons of this yield as substantial agreement between measured and computed data was obtained.

Results from films and glass-phosphate dosimeters of total initial gamma are in substantial agreement with theoretical predictions. At 110 yards, an average dose of 243 r was measured, and at 310 yards 18 r was measured.

The neutron dose was measured from a slant distance of 576 to 1,550 yards. The measured dose, using sulfur activation and track population counting in neutron films, agreed with theoretical estimates.

The decay rate detected by an MG-3 ion chamber buried at 30 yards from ground zero indicated only fission-product decay. No neutron-induced activation of the soil was apparent from the data obtained.

Fallout was not recorded by the MG-3 installation in the path of predicted fallout as dose-rate levels were not sufficiently high to activate the instrument. Satisfactory operation of the instrument located at 30 yards proved to be an adequate field test of the instrument.

## *PREFACE*

The preparations and field work of this experiment were made possible by the assistance of: R. F. Merian, M/Sgt W. P. Schaus, and A/2C R. Cowles of the Air Force Special Weapons Center, Kirtland Air Force Base, New Mexico. Assistance in the reduction of data was given by: J. A. Blaylock and M/Sgt J. M. Pulliam of the Air Force Special Weapons Center; Clarence Slover of the Lexington Signal Depot, who processed the LSD film dosimeters; and Fred Riggins of the New York Naval Shipyard, who read the glass needle dosimeters.

# CONTENTS

FOREWORD	4
ABSTRACT	5
PREFACE	6
CHAPTER 1 INTRODUCTION	9
1.1 Objectives	9
1.2 Background and Theory	9
1.2.1 Initial-Gamma Dose Rate versus Time	9
1.2.2 Neutron Dose	10
1.2.3 Induced-Activity Decay Rate	10
CHAPTER 2 PROCEDURE	12
2.1 Operations	12
2.2 Gamma Measuring Devices	12
2.2.1 Kaiser Electronic Automatic Dose Rate Instrument	12
2.2.2 Film	19
2.2.3 Radiac Detector DT-60/PD	22
2.2.4 Glass Needles	22
2.2.5 Gamma Radiation Fallout Detector (MG-3)	22
2.3 Neutron Measuring Devices	24
2.3.1 Sulfur	24
2.3.2 Neutron Film	25
2.3.3 RTF Dosimeters	25
2.4 Data Requirements	28
CHAPTER 3 RESULTS AND DISCUSSION	29
3.1 Initial-Gamma Dose Rate	29
3.2 Total Initial-Gamma Dose	33
3.3 Neutron Dose	37
3.3.1 Sulfur Activation	37
3.3.2 Nuclear Track Emulsions	38
3.3.3 Resonance-Threshold Foil Dosimeters	38
3.3.4 Summary	39
3.4 Neutron Induced Activity	42
3.5 Field Test of MG-3	42
CHAPTER 4 CONCLUSIONS AND RECOMMENDATIONS	43
4.1 Conclusions	43
4.2 Recommendations	43
REFERENCES	44

## FIGURES

2.1 Dose-rate instrumentation and generator at 425 yards on the 85-degree axis	13
2.2 Location of close-in MG-3 detector head	13
2.3 Station plot plan	14
2.4 Kaiser dose-rate instrument, showing probe, compressor-oscillator- amplifier unit, and power supply (top to bottom)	15
2.5 Block diagram nuclear dose-rate measuring instrument	16
2.6 Kaiser dose-rate instrument, gamma scintillation probe	18
2.7 Kaiser dose-rate instrument, oscillator and compression circuit	19
2.8 Dose-rate instrument, regulated power supply	20
2.9 Calibration curve for Kaiser dose-rate instruments, 750-yard station	21
2.10 Diagram of Kaiser playback-and-readout equipment	22
2.11 Calibration curve for 500-curie $\text{Co}^{60}$ source	23
2.12 Calibration curves for NBS dosimeter film	24
2.13 Fallout detector (MG-3), showing detector, indicating, and recording units	25
2.14 Detector and indicator of MG-3	26
2.15 MG-3 detector installation	27
2.16 Calibration for neutron films, rad versus tracks per field	27
3.1 Initial-gamma dose rate versus time at 750 yards, 85-degree axis	30
3.2 Initial-gamma dose rate versus time at 550 yards, 85-degree axis	30
3.3 Summary of dose-rate data	32
3.4 Integrated initial-gamma dose percent of total dose versus time, 750 yards	32
3.5 Summary of initial gamma, $\text{RD}^2$ versus D	33
3.6 Neutron dose, $\text{RD}^2$ versus D, from sulfur activation on 0-degree axis	36
3.7 Neutron dose, $\text{RD}^2$ versus D, from sulfur activation on 85- degree axis	36
3.8 Neutron dose from Types A and B film, 0-degree axis, $\text{RD}^2$ versus D	40
3.9 Neutron dose from Types A and B film, 85-degree axis, $\text{RD}^2$ versus D	40
3.10 Summary of neutron dose	41
3.11 MG-3 data at underground station, 30 yards from ground zero	41

## TABLES

1.1 Isotope Half Lives and Energies	11
2.1 Instrument Location	17
2.2 Calibration and Reading of Instrumentation	18
3.1 Initial-Gamma Dose Rate versus Time	31
3.2 Initial-Gamma Dose versus Slant Distance, 0-degree Axis	34
3.3 Initial-Gamma Dose versus Slant Distance, 85-degree Axis	34
3.4 Neutron Dose from Sulfur Activation, 0-degree Axis	37
3.5 Neutron Dose from Sulfur Activation, 85-degree Axis	38
3.6 Neutron Dose from Types A and B Film, 0-degree Axis	39
3.7 Neutron Dose from Types A and B Film, 85-degree Axis	39

# Chapter 1

## INTRODUCTION

### 1.1 OBJECTIVES

The primary objective of this project was to measure nuclear radiation from a very-low-yield detonation, specifically: (1) initial gamma dose rate, (2) total initial gamma dose, (3) total neutron dose in low-dose regions, and (4) rate of induced-activity decay of Nevada Test Site soil.

A secondary objective of this project was to field-test a prototype of the standard Air Force fallout detector (designated MG-3).

### 1.2 BACKGROUND AND THEORY

In this report the initial nuclear radiation associated with a nuclear detonation is considered to include the gamma and neutron radiation emitted during the first 20 seconds after an air burst.

During the delivery of an air-to-air nuclear warhead, the air-crew dose is received essentially in two increments. The first increment, i. e., neutron dose, gamma radiation associated with the fission process, and gamma dose arising from the capture of neutrons by the nitrogen in the air, is received within a fraction of a second after the detonation. This dose is solely a function of the distance of the aircraft from the point of detonation and must be accepted for an air-to-air delivery of any specific rocket. The second, and final, portion of the dose is received during the escape maneuver (the flight path of the aircraft subsequent to the delivery) and arises from the fission-product gamma rays. For a stationary observer the fission-product portion of the total gamma dose is less than 20 percent of the total (depending on the range), but this fraction is increased considerably in the case of an aircraft moving toward a detonation after it has taken place. Consequently, the escape maneuver is a critical parameter in the employment of air-to-air nuclear warheads. With the increased speeds of modern supersonic interceptor aircraft, optimum escape maneuver programming to minimize the air-crew radiation dose is essential.

1.2.1 Initial-Gamma Dose Rate versus Time. Gamma rate versus time has been measured during Operations Buster-Jangle (Reference 1), Jangle (Reference 2), Redwing (Reference 3), and Plumbbob (Reference 4). The data obtained during Operation Buster-Jangle are not directly applicable to air bursts, as the measurements were made on a surface and for an underground shot. The delivery rate of the initial gamma radiation and the total gamma dose from an air burst are significantly different when compared with surface or underground bursts. Operation Redwing measurements were concerned primarily with megaton-range devices.

The data obtained from Operations Buster-Jangle and Plumbbob form the basis of existing methods of predicting gamma doses received by aircrews during the escape maneuver subsequent to the delivery of the air-to-air, nuclear-warhead, MB-1 rocket (References 5 and 6).

With the advent of fractional-kiloton nuclear warheads suitable for fighter delivery, the validity of using existing dose-prediction techniques based on kiloton-range measurements must be sub-

stantiated. As no determinations of initial-gamma dose rate versus time had been made for nuclear detonations in this yield range, these measurements were necessary to experimentally substantiate existing scaling methods or provide a basis for obtaining new extrapolation methods.

Much of the effectiveness of the employment of very-low-yield weapons will depend upon the range at which they can safely be delivered. The position of the aircraft at burst time and its subsequent maneuvers for the next 20 seconds will largely determine this range from a nuclear-radiation standpoint.

**1.2.2 Neutron Dose.** Neutron dose has been measured during practically all past nuclear tests; but for the most part, these have been concerned with dose levels in excess of those of interest in the delivery of air-to-air missiles. No measurements had been made of the neutron dose from fractional-kiloton yields below the limits of fission-foil-technique sensitivity, i. e., 10 rep. Since this dose region corresponds to that of operational interest to the Air Force, measurements in this range are required.

Several techniques appear to be adaptable to measurements of low neutron dose. Types A and B Kodak personal-monitoring films have been successfully used in the past for other applications (References 7 and 8). The resonance-threshold foil dosimeter (Reference 9) developed by General Electric permits an evaluation of the neutron spectrum to be made by determining the activation of various foils. An energy-corrected total dose can thus be found with this method.

The possibility of using sulfur to determine the neutron dose in the low-dose region had been under investigation for some time (Reference 10). Measurements during past nuclear tests have demonstrated that the biological neutron dose closely follows the sulfur neutron flux for fission weapons:

$$\text{Rem}_0 = \frac{I_0}{(1.52 \pm 0.76) \times 10^7}$$

where  $I_0$  = the sulfur neutron flux at 1 yard ( $n/cm^2$ ) and  $\text{Rem}_0$  = the neutron dose at 1 yard. It can be seen that  $I/\text{Rem}$  will be constant over the distances of interest if the sulfur mean free path is equivalent to the neutron dose mean free path, since:

$$I = \frac{I_0 e^{-DR/\lambda}}{D^2}$$

$$\text{Rem} = \frac{\text{Rem}_0 e^{-DR/\lambda}}{D^2}$$

Where:  $D$  = distance from the source

$R$  = relative air density, correcting the mean free path back to the atmospheric conditions existing at shot time

$\lambda$  = mean free path for standard ICAO atmosphere (15 C and 760 mm Hg).

Reference 11 shows that the neutron spectrum does not vary from one to six mean free paths. Splenic and thymic weight-loss measurements of mice exposed to fission neutrons have yielded an average mean free path of  $212 \pm 55$  yards. The mean free path for NACA atmosphere of sulfur neutrons is 210 yards. For fractional-kiloton yields, this direct relationship should hold for all doses of operational interest, as these occur well within a range of ten neutron mean free paths.

**1.2.3 Induced-Activity Decay Rate.** One source of radioactivity formed during a nuclear detonation is the induced activity in the soil resulting from the activation by neutrons of the soil

constituents. Of military importance are the initial level of this induced activity and its rate of decay. It appears that the most-significant isotopes produced in most soils are  $\text{Na}^{24}$ ,  $\text{Al}^{28}$ , and  $\text{Mn}^{56}$  (Table 1.1).

The results of experimental measurements made during Operations Teapot, Redwing, and Plumbbob are given in References 12, 13, 14, and 15. Although early measurements of the

TABLE 1.1 ISOTOPE HALF LIVES AND ENERGIES

Isotope	Formed By	Half Life	Energy of Emitted
			$\gamma$ Radiation
			Mev
$\text{Al}^{28}$	$\text{Al}^{27} (n, \gamma) \text{Al}^{28}$	2.3 min	1.78
$\text{Mn}^{56}$	$\text{Mn}^{55} (n, \gamma) \text{Mn}^{56}$	2.58 hrs	0.85, 1.8, 2.1
$\text{Na}^{24}$	$\text{Na}^{23} (n, \gamma) \text{Na}^{24}$	15 hrs	2.8, 1.4

intensity and decay of the induced field were attempted during these operations, no successful documentation was accomplished, owing to various technical or operational difficulties. With the advent of fractional-kiloton ground weapons, the decay rate at a few minutes after the detonation can be a significant parameter in their employment. Aluminum, with the short half life indicated in Table 1.1, is the primary contributor to the dose levels at these times.

## Chapter 2

# PROCEDURE

### 2.1 OPERATIONS

The objectives of this project were such that only a fractional-kiloton detonation above ground permitted useful information to be obtained. Shot Hamilton best fitted these requirements.

Detectors and measuring devices were located along two surface lines at approximately right angles to each other.

Film badges and associated equipment located from 0 to 600 yards from ground zero on the 0-degree azimuth were placed inside standard 3-inch steel pipes and attached to the CWL cable (Project 2.12). This cable was drawn back to a safe distance at approximately H + 5 minutes for recovery of equipment, thereby minimizing the film exposure resulting from induced or fall-out activity. The film badges and associated equipment were removed from the pipes approximately 30 minutes after shot time.

The film badges and associated equipment located from 300 to 1,600 yards from ground zero on both lines (0 and 85 degrees) were attached to stakes driven into the ground. The RTF (resonance-threshold-foil) dosimeters located outside 650 yards on the 0-degree azimuth were recovered 7 minutes after the shot. The other equipment was recovered within 2 hours after shot time.

The initial-gamma-dose-rate instruments were inside  $\frac{3}{4}$ -inch plywood sealed boxes anchored to the ground by 12-inch metal stakes and located 425, 550, and 750 yards from ground zero on the 85-degree azimuth (Figure 2.1). These instruments were recovered 2 hours after the shot.

One low-resolution dose-rate detector head (MG-3) was blast protected and located 30 yards from ground zero on the 85-degree azimuth. Figure 2.2 shows the location of the detector head in the foreground. The power supply and recorder for the instrument were shock mounted and located 320 yards from the detector head and connected by a protected cable. A second MG-3 was located 650 yards from ground zero on the 85-degree axis. The unit was placed in a box made of  $\frac{3}{4}$ -inch plywood and secured to the ground by 12-inch metal stakes.

Late evacuation (H - 2 $\frac{1}{2}$  hours) was required in order to turn on power for the initial-dose-rate instrumentation. Early re-entry (H + 5 minutes) was required in order to detach equipment from the CWL cable and for recovery of resonance-threshold-foil dosimeters.

The location of instrumentation stations in relation to ground zero is indicated in Figure 2.3. The instrumentation placed at the various locations is indicated in Table 2.1.

### 2.2 GAMMA MEASURING DEVICES

2.2.1 Kaiser Electronic Automatic Dose Rate Instrument. Instruments (Figure 2.4) developed by the Kaiser Aircraft and Electronics Corporation for the Air Force Special Weapons Center were modified to measure initial-gamma dose rates at three locations. The recording system used in conjunction with the measuring device utilized an Ampex Corporation AR102 Airborne magnetic-tape recorder. A block diagram of the system is shown in Figure 2.5.

The dose-rate instrument required 28 volts dc, and the recorder used 110 volts ac at 400 cps along with 28 volts dc. This power was supplied at each location by a standard Air Force portable generator, Type B-10-B, usually used for aircraft starting. The generators were started manually at H-3 hours. Activation of the instrument was accomplished by an Edgerton, Germeshausen & Grier (EG&G) hard-wire timing signal at H-15 minutes. A hold-down relay was used

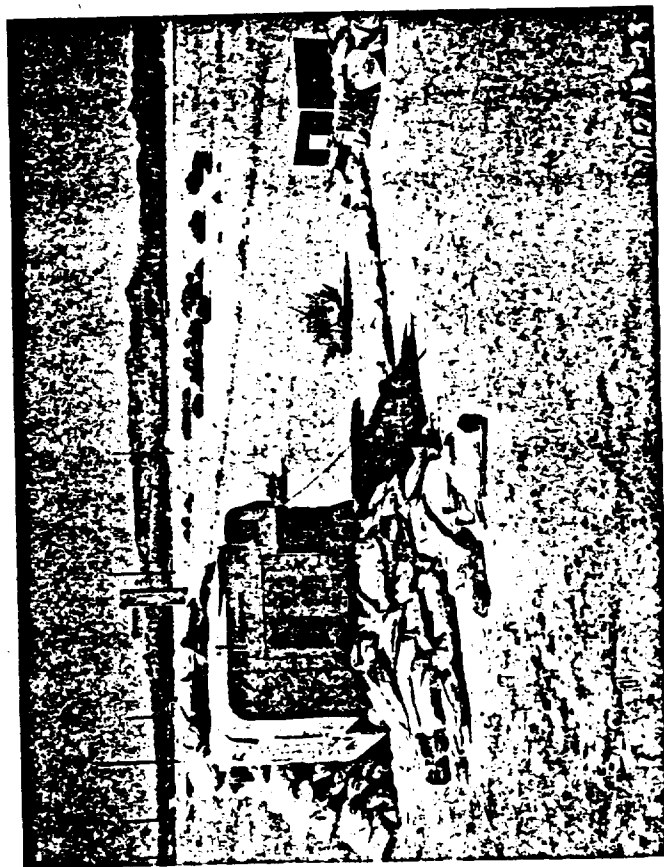

Figure 2.1 Dose rate instrumentation and generator at 425 yards on the 85-degree axis.

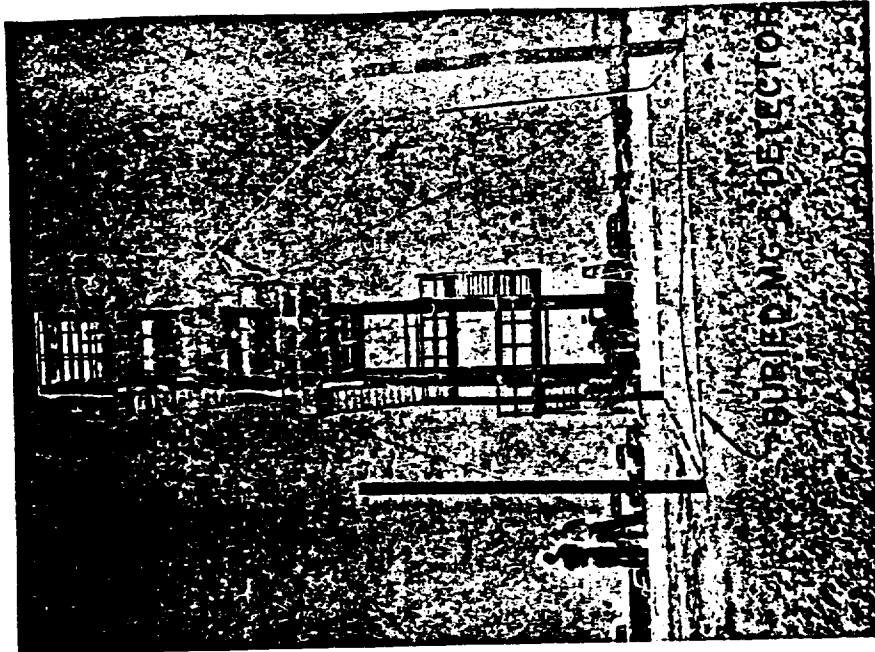

Figure 2.2 Close-in MG-3 detector head location.

to keep the circuit closed after the timing signal expired. As the generators would not operate under no-load conditions for the length of time required (from H - 3 hours until after shot time), a resistance with a rating of 7.6 ohms and capable of dissipating 1,600 watts was placed in parallel with the instrumentation. This load served to prevent spark plug fouling and other conditions concomitant with no-load operation. The resistances were not disconnected when the instruments went into operation, since the instruments required little amperage.

The output of the scintillation probe and photomultiplier of the dose-rate instrument was direct current ranging from 0.05 to 500  $\mu$ a for minimum to maximum incident gamma fluxes. The di-

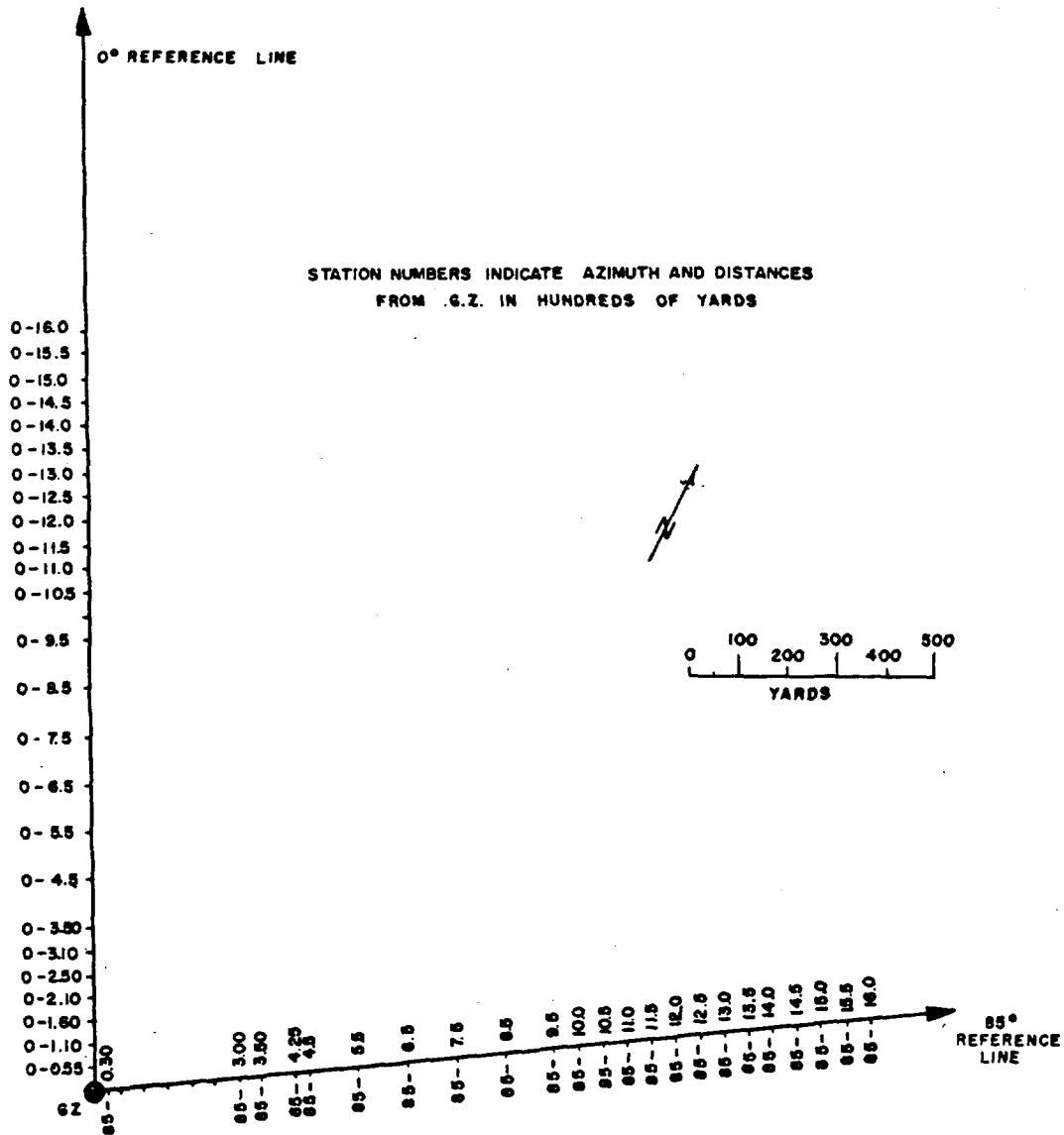

Figure 2.3 Station plot plan.

rect current was impressed into the compressor-oscillator unit. In this unit, the direct current was converted to pulses by a blocking oscillator. The pulses were amplified and recorded on magnetic tape.

The probe consisted of an energy-compensated aluminum hemisphere with an interior plastic scintillant. The entire surface of the hemisphere was coated with silver-activated zinc sulfide, ZnS(Ag), and responded predominantly to gamma-ray energies below 130 kev. The light from this coating and from the plastic scintillation crystal was converted by the photomultiplier to an

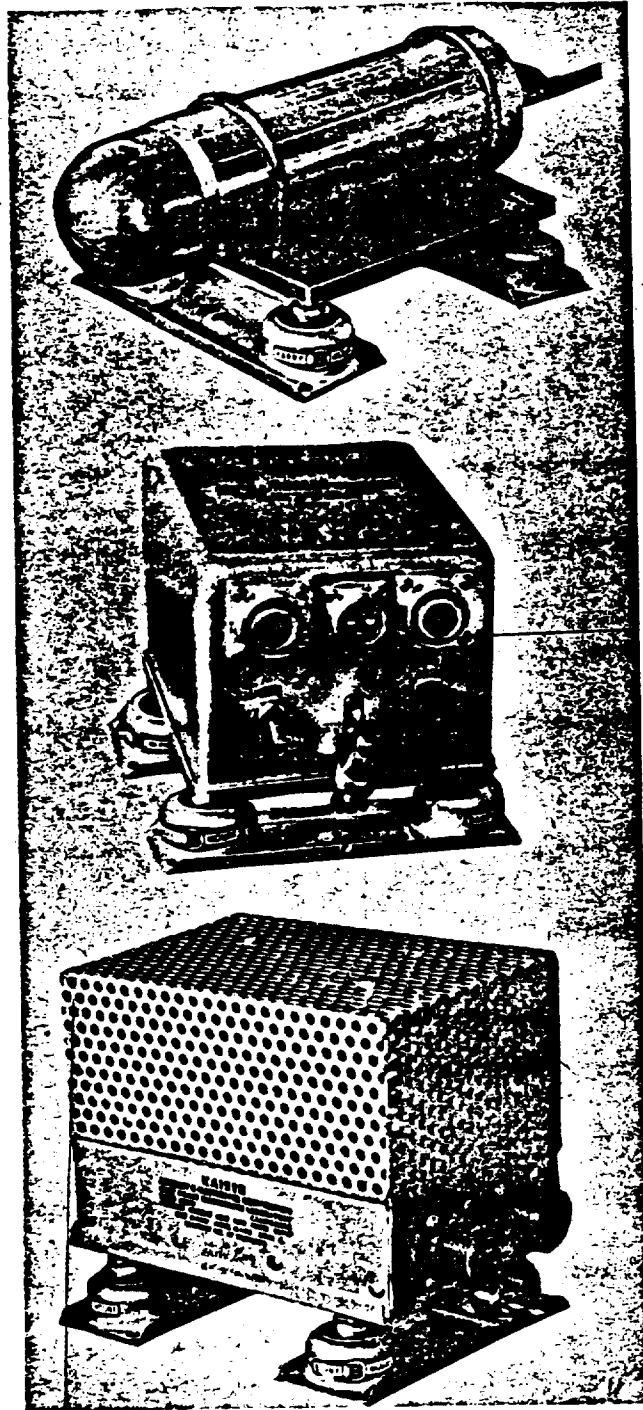

Figure 2.4 Kaiser dose-rate instrument, showing probe, compressor-oscillator-amplifier unit, and power supply (top to bottom).

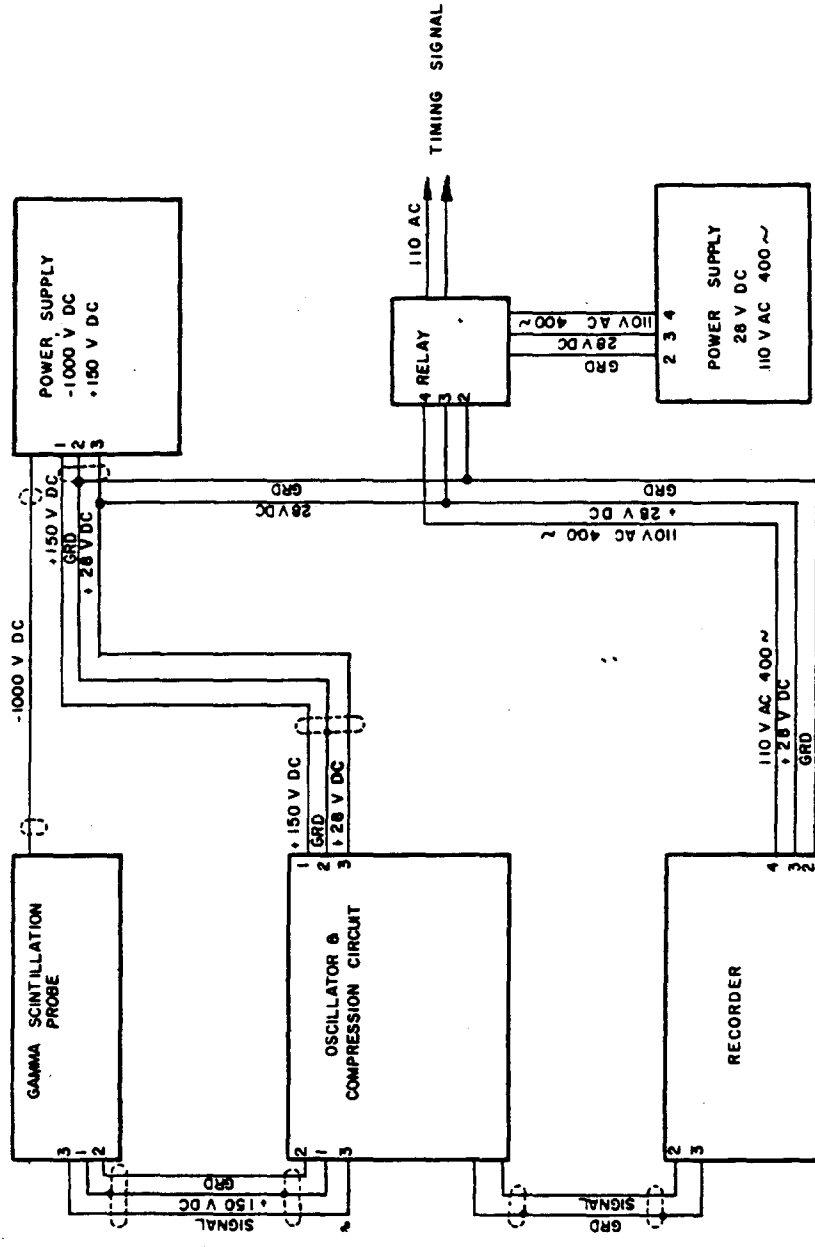

Figure 2.5 Block diagram nuclear dose-rate measuring instrument.

TABLE 2.1 INSTRUMENT LOCATION

Station	NBS Film Packs, Du- pont 502- 510-834, 0- and 85- deg Axis	Kodak 548-0 Film, 0-deg Axis	LSD Film Stacks, Du- pont 606- 502-606, 0- and 85- deg Axis	LSD Film Packs, Du- pont 555- 1290, 0- and 85- deg Axis	Glass Needles 0- and 85-deg Axis	DT-60, 0- and 85-deg Axis	Kaiser, 85-deg Axis	Type A, 0- and 85-deg Axis	Type B, 0- and 85-deg Axis	RTF Doel- meter	Sulfur Planchets 0- and 85-deg Axis	Sulfur Bags 0- and 85-deg Axis	MG-3 85-deg Axis
30*													▲
55†	▲	▲	▲	▲	▲						▲		
110†	▲	▲	▲	▲	▲						▲		
160†	▲	▲	▲	▲	▲						▲		
210†	▲	▲	▲	▲	▲	▲					▲		
250†	▲	▲	▲	▲	▲	▲					▲		
300	▲	▲	▲	▲	▲	▲					▲	▲	
350	▲	▲	▲	▲	▲	▲					▲	▲	
425*	▲	▲	▲	▲	▲	▲	▲				▲	▲	
450	▲	▲	▲	▲	▲	▲					▲	▲	
550	▲	▲	▲	▲	▲	▲	▲				▲	▲	
650	▲	▲	▲	▲	▲	▲				▲	▲	▲	▲
750	▲	▲	▲	▲	▲	▲	▲			▲	▲	▲	
850	▲	▲	▲	▲	▲	▲		▲	▲	▲	▲	▲	
950	▲	▲	▲	▲	▲	▲		▲	▲	▲	▲	▲	
1,000*	▲	▲	▲	▲	▲	▲		▲	▲	▲	▲	▲	
1,050	▲	▲	▲	▲	▲	▲		▲	▲	▲	▲	▲	
1,100	▲	▲	▲	▲	▲	▲		▲	▲	▲	▲	▲	
1,150	▲	▲	▲	▲	▲	▲		▲	▲	▲	▲	▲	
1,200	▲	▲	▲	▲	▲	▲		▲	▲	▲	▲	▲	
1,300	▲	▲	▲	▲	▲	▲		▲	▲	▲	▲	▲	
1,350	▲	▲	▲	▲	▲	▲		▲	▲	▲	▲	▲	
1,400	▲	▲	▲	▲	▲	▲		▲	▲	▲	▲	▲	
1,450	▲	▲	▲	▲	▲	▲		▲	▲	▲	▲	▲	
1,500	▲	▲	▲	▲	▲	▲		▲	▲	▲	▲	▲	
1,550	▲	▲	▲	▲	▲	▲		▲	▲	▲	▲	▲	
1,600	▲	▲	▲	▲	▲	▲		▲	▲	▲	▲	▲	

\* Indicates station on the 85-degree axis only.

† Indicates station on the 0-degree axis only.

electron flow that was directly proportional to the amount of light given off by the phosphor. The plastic scintillant responded to energies above 130 kev. While the responses of the two phosphors overlapped, the additive error was only 3 to 4 percent in the neighborhood of this dividing line. Figure 2.6 is a schematic of the circuit associated with scintillation probe and photomultiplier.

In the compressor-oscillator-amplifier unit, the direct current from the scintillation probe was converted to pulses by the blocking-oscillator tube (V-1 in Figure 2.7), which operated in a conventional manner. The compression circuit regulated the oscillator repetition rate by varying the bias on the tube (V-2 in Figure 2.7), when the tube was conducting, to supply the current demanded by the photomultiplier. Advantage was taken of the low-voltage characteristics of a low- $\mu$  triode to provide a logarithmic response in the compression circuit. The oscillator

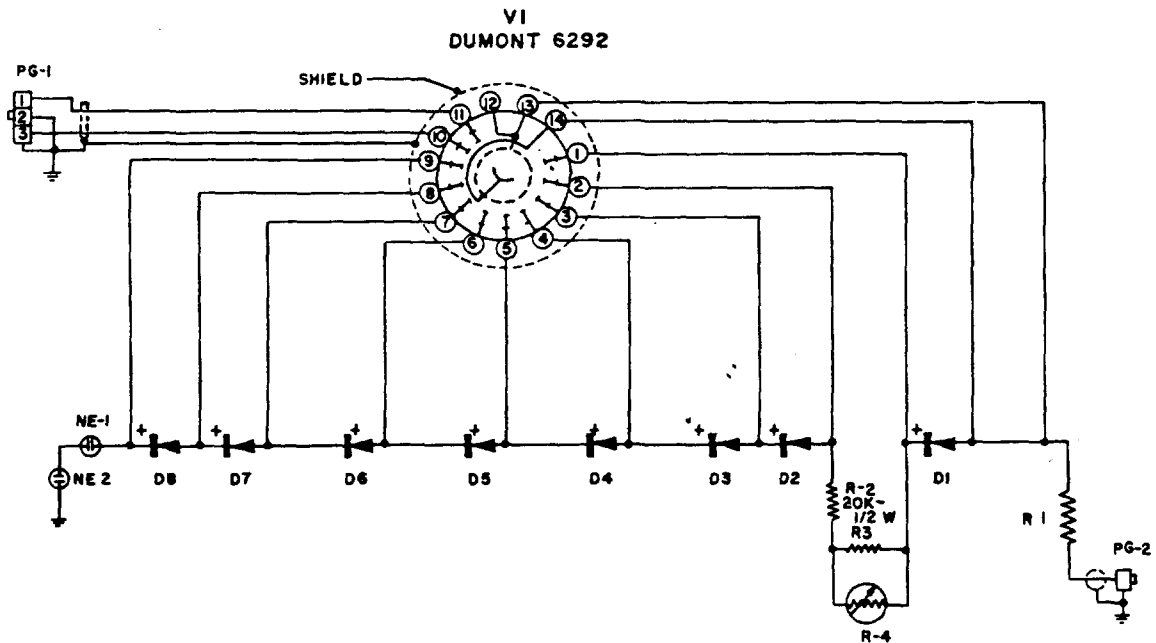

Figure 2.6 Kaiser dose-rate instrument, gamma scintillation probe.

output was taken from the plate of V-1 and applied to the grid of the amplifier tube (V-3 in Figure 2.7). The pulse from the oscillator drove the amplifier tube to cutoff and resulted in an output of 90 volts. The amplifier output was then applied to the recorder.

The power supply of the instrument furnished 28, 150, and 1,000 volts dc to the system. The 28 volts was applied through the center tap of a transformer to the plates of six 26A7-GT tubes in parallel. One of the transformer secondaries supplied 180 volts ac to V-7 (Figure 2.8) for rectification and to V-8, -9, and -10 for regulation to 150 volts dc. The 640-volt output of the other secondary was rectified and doubled through the action of two sets of seven germanium rectifiers. Tubes V-9 and V-10 regulated this potential to -1,000 volts.

Several modifications were required in the original instruments to obtain the characteristics necessary for this application. The plastic scintillant's size was decreased and its shape changed to decrease its sensitivity. This was necessary to obtain the 0.05-to-500- $\mu$ a output of the original design in spite of higher levels of incident gamma flux. The output-frequency range of the blocking-oscillator circuit was increased by a factor of forty to 2,000 to 12,000 cps, to provide a 1-msec response time. To realize this response time, a quality Ampex magnetic-tape recorder was substituted for the wire recorder in the original instrument.

The compressor circuit output was checked for linearity with microampere inputs. The circuit response for inputs corresponding to dose rates up to 40,000 r/hr was linear for a typical instrument. The instruments were also subjected to a burst from the Godiva II assembly at

Los Alamos. At a distance of 200 cm, no permanent neutron damage occurred. During the time period when the dose rate was within the recording range of the instrument, no transient blackouts or spurious signals were recorded. Calibration of the instruments was accomplished at Los Alamos using a 100-curie  $\text{Co}^{60}$  source. The resulting calibration curve (frequency versus  $r/\text{hr}$ ) for a representative instrument is presented in Figure 2.9. Geometry considerations dictated the positioning of the probe from 10 to 170 cm from the source to achieve the desired dose rates.

Frequency versus time was recorded on the Ampex tape recorder from time zero to  $H + 60$  seconds. In order to change this frequency to a voltage necessary to drive the Bristol chart

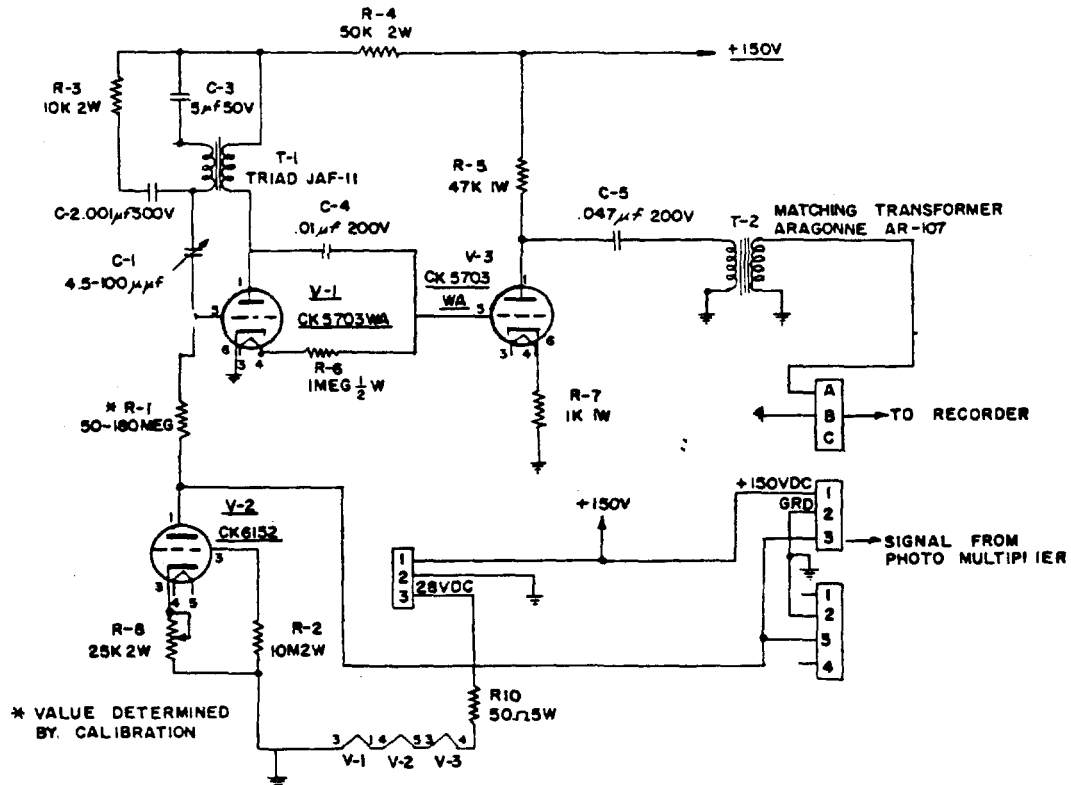

Figure 2.7 Kaiser dose-rate instrument, oscillator and compression circuit.

recorder, the system illustrated in Figure 2.10 was used. The curves produced on the Bristol recorder chart served as calibration checks.

The two types of recorders in Steps 1 through 5 (Figure 2.10) were used to stretch the time scale by a factor of sixteen. The signal output from Step 5 was amplified, clipped, and differentiated in Steps 6 through 8 in order to accurately trigger the one-shot multivibrator in Step 9. The output pulses from the multivibrator were of constant amplitude and width but with a repetition rate equal to the input triggering signal. These signals were integrated and then recorded on the Bristol chart recorder as voltage versus time in Steps 10 and 11.

**2.2.2 Film.** Film was used to record the total gamma dose at the stations indicated in Table 2.1. Standard NBS film holders (including Kodak 548-0 and Dupont 553, which contains D502, D510, and D834 film) and Lexington Signal Depot film packs and film stacks were used as shown in Table 2.1.

The Lexington Signal Depot calibrated the film exposed in their holders using  $\text{Co}^{60}$ . The sources of radiation used to calibrate the NBS film packets were a 500-curie  $\text{Co}^{60}$  source at EG&G and a 7-curie  $\text{Co}^{60}$  source at Kirtland Air Force Base.

The 500-curie source was encased in a uranium shield. The source was located  $2\frac{1}{2}$  inches from a window at the front of the shield. The window could be removed and the source rotated

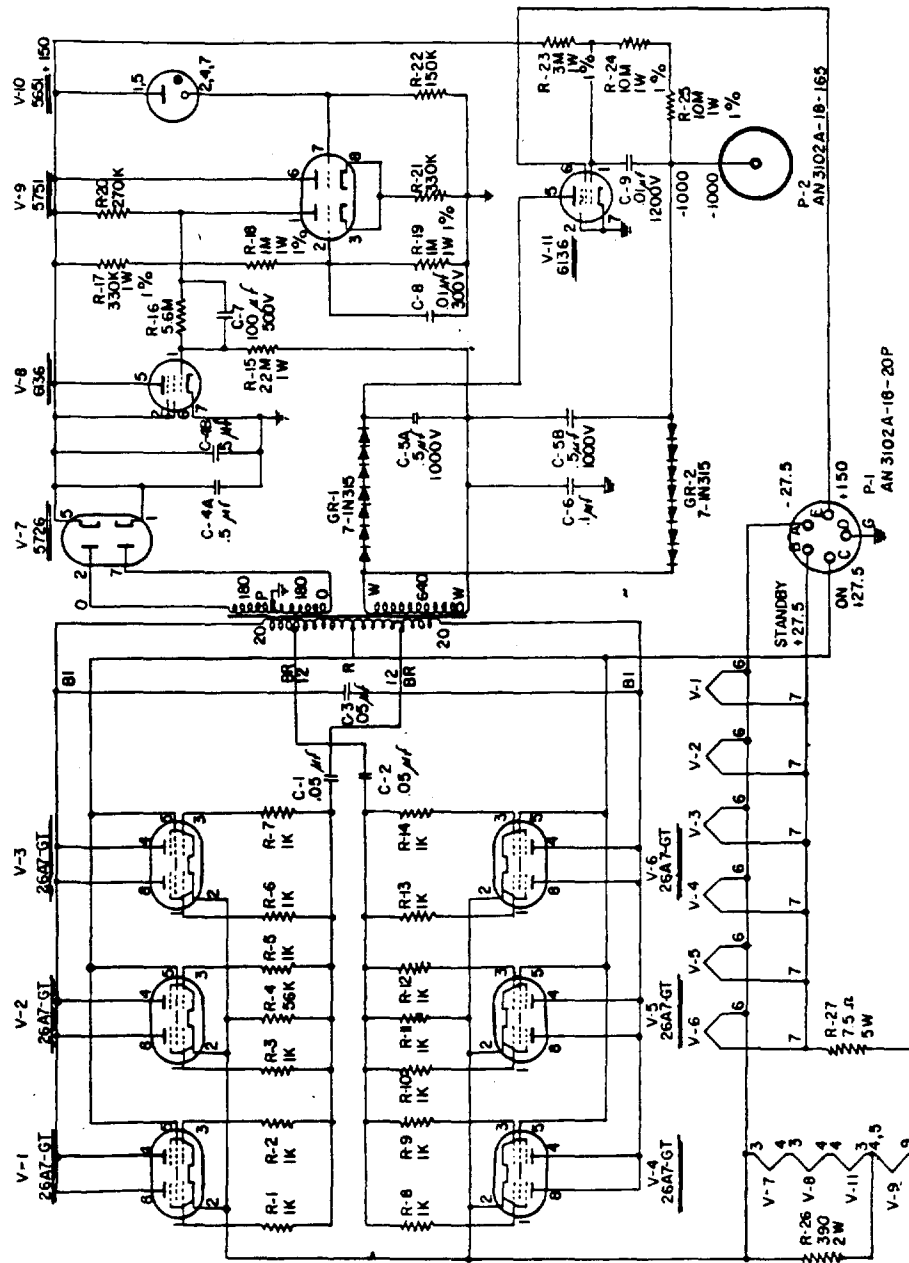

Figure 2.8 Dose-rate instrument, regulated power supply +150 volts, -1,000 volts.

in place in less than 1 second. Putting the source in position was done remotely from the control room. The source had been calibrated by the use of a Victoreen R-meter, which was calibrated at the National Bureau of Standards to an accuracy of  $\pm 3$  percent. The source calibration curve is shown in Figure 2.11. The configuration of the source room was such that only one NBS film holder could be exposed at one time. The Kodak 548-0 film packets were placed inside

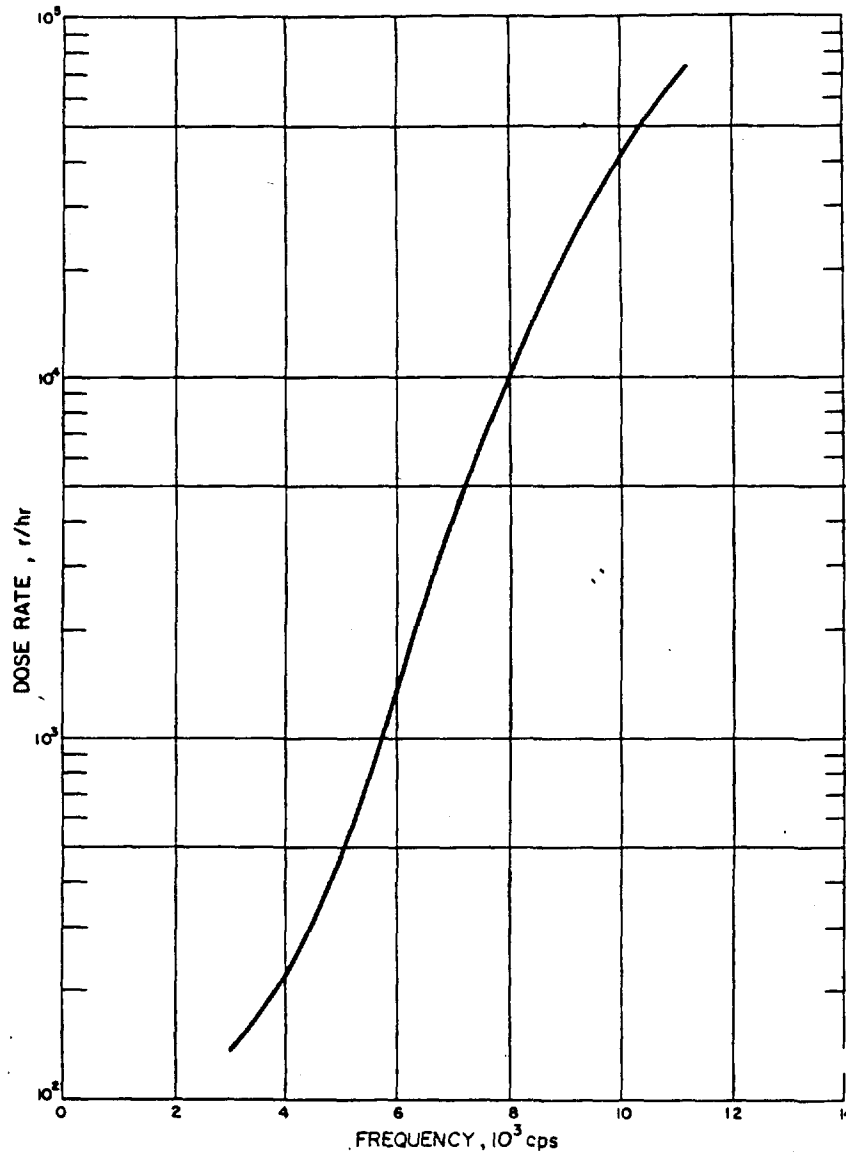

Figure 2.9 Calibration curve for Kaiser dose-rate instrument, 750-yard station.

their NBS holders at  $5\frac{1}{2}$  inches from the window of the shield and exposed from 200 to 1,400 seconds, giving the film a total dose from a minimum of 1,000 r to a maximum of 7,000 r.

The Dupont 553 film packets inside their NBS holders were placed at distances of  $5\frac{1}{2}$  to 112 inches from the shielded window and exposed from 40 to 400 seconds to give the film exposures within the range of 1 to 2,000 r. The calibration curves are shown in Figure 2.12.

All of the Kodak 548-0 film packs were calibrated inside a steel pipe holder. The Dupont 553 film packs were calibrated both inside and outside the pipe holders.

The 7-curie source was used to calibrate the film for small total doses. The film packets inside their NBS holders were exposed to a total dose from a minimum of 0.1 r to a maximum

of 10 r. The agreement of the calibration from 1 to 10 r using the two sources was satisfactory, the difference being less than 1 percent.

The photographic-transmission densities were read on a film densitometer designed by the Los Alamos Scientific Laboratory and built by the Eberline Instrument Corporation.

**2.2.3 Radiac Detector DT-60/PD.** Approximately 160 personnel dosimeters (DT-60/PD), four to a location, were used at positions indicated in Table 2.1. This gamma detector covers an exposure range from 0 to 600 r. The detectors were read before the shot on a calibrated standard reader to determine predose readings.

**2.2.4 Glass Needles.** Approximately 160 glass-needle, phosphate-glass dosimeters, eight to a station, were used to measure the total gamma dose at positions indicated in Table 2.1. The dosimeter consisted of a small glass phosphate needle inside a teflon sleeve, which in turn

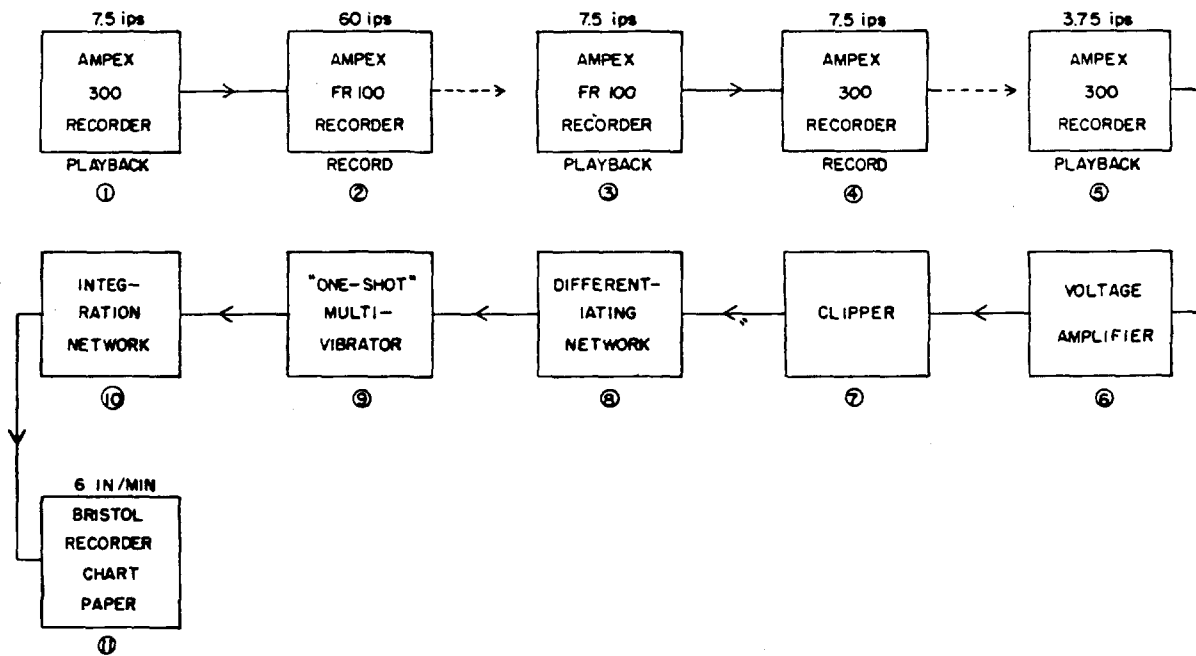

Figure 2.10 Block diagram of Kaiser playback-and-readout equipment.

was encased in a lead shield with walls 2 mm thick. After exposure to gamma radiation, the response of these glass dosimeters was indicated by an increase in fluorescence upon illumination by ultraviolet light. The glass needles were air mailed to Brooklyn Naval Shipyard immediately after the shot so that the indicated dose could be ascertained.

**2.2.5 Gamma Radiation Fallout Detector (MG-3).** The MG-3 is a battery-powered, self-recording set. It was designed and fabricated by Technical Operations, Inc., under contract with the Air Force for the purpose of studying the use of such a unit as a part of an integrated fallout-countermeasure system. This instrument measured X- and gamma-ray dose rates from 1.0 to 1,000 r/hr with an accuracy of  $\pm 10$  percent of the indicated reading.

The sets consisted of ruggedized detector, indicator, and recorder units (Figure 2.13). The detector unit had an ion chamber for the sensing device. In common with all ion chambers, ionizing radiation caused a flow of current whenever there was a voltage across the ion chamber. In this case, there was a nonlinear relation between the amount of radiation and the amount of current. This relation was fixed by the geometry of the chamber and the fact that the chamber was operated in a nonsaturated region, i. e., the voltage was inadequate for collecting ions as fast as

they were formed. Feedback was employed to reduce the chamber voltage as the amount of radiation increased. Even though the amplifier was linear, the combined effect was to produce a nonlinear scale on the meter.

The components in the indicator unit included a transistor amplifier, a built-in alarm system, batteries, a built-in calibration source, and a direct-reading meter.

The amplifier had a small current for an input. An output current of up to 1.0 ma operated the indicator. One feedback potential was developed across the metering circuit and varied

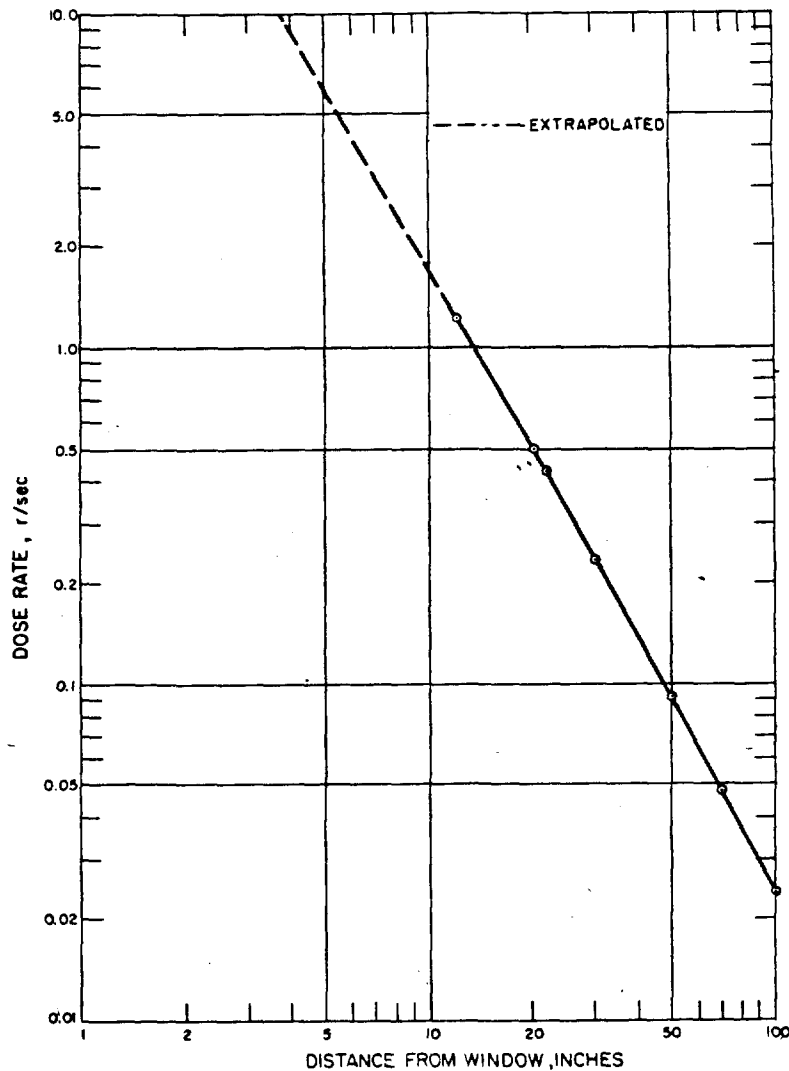

Figure 2.11 Calibration curve for 500-curie  $\text{Co}^{60}$  source.

from 0 to about 20 volts. Another feedback voltage to the chamber was applied to the positive end of the chamber voltage battery. A schematic diagram of the detector and indicator is shown in Figure 2.14.

There was a built-in alarm system incorporated in the MG-3 unit. When the radiation level reached approximately 0.5 r/hr, a relay was closed and an alarm buzzer was turned on.

Power for the unit was supplied by six batteries ranging from 1 to 21 volts. The normal life of all the batteries was 6 months of continuous operation. The battery that operated the alarm could operate continuously for 18 hours with the alarm turned on.

Also built into the unit was a standardizing source. The radioactive material was krypton gas ( $Kr^{85}$ ). The source was hermetically sealed. It had a thin, stainless-steel window through which beta radiation reached the ion chamber when the source control was turned on.

The recorder unit was an Esterline-Angus strip type with a spring-operated paper drive. The chart drive was capable of speeds ranging from 12 in/min to  $\frac{3}{4}$  in/hr. The recorder charts of both MG-3 units were operated at a speed of  $\frac{3}{4}$  in/min; each chart was 100 feet long. The two instruments were located 650 and 30 yards from ground zero, the former to measure fallout and the latter to measure the rate of decay of activity produced in the soil by the neutrons escaping from the device. The steel case of the close-in detector was surrounded by 6 inches of boric acid and 12 inches of paraffin to minimize activation of the case itself. It was placed in a hole

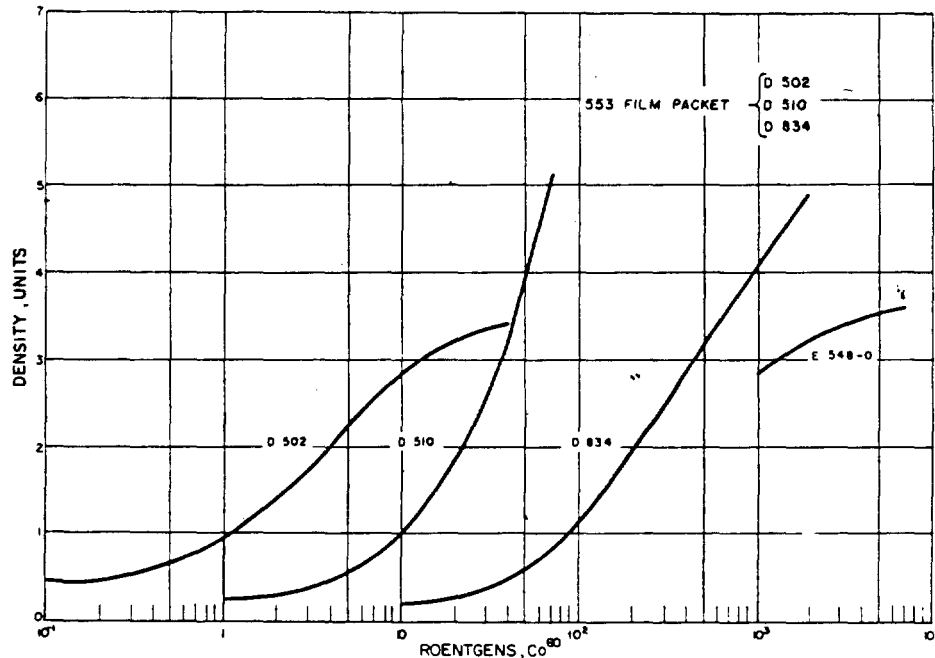

Figure 2.12 Calibration curves for NBS dosimeter film.

4 feet square and 4 feet deep and covered by a thickness of 4-by-4 lumber and two layers of sandbags (see Figure 2.15). It was connected to the power supply and recorder by 1,000 feet of cable buried 6 inches under the surface.

### 2.3 NEUTRON MEASURING DEVICES

Neutron flux was measured with sulfur bags, sulfur planchets, nuclear-track emulsions, and neutron dosimeters (Table 2.1).

**2.3.1 Sulfur.** Common  $S^{32}$  when irradiated with neutrons above 2.5 Mev energy, undergoes an (n,p) reaction to become  $P^{32}$ , a  $\beta^-$  emitter. When the  $\beta^-$  emission is counted, the flux of neutrons with energies above 2.5 Mev can be calculated, and consequently, the neutron dose can be estimated (see Section 1.2.2).

Sulfur pellets and planchets have often been used in this manner. One limitation of this method is that the pellets and planchets cannot measure doses below approximately 1 rem with conventional counting equipment.

To measure an extremely low flux of neutrons above 2.5 Mev energy, large samples of sulfur (800 grams in this case) can be exposed and the activity concentrated by burning the whole sample in one planchet. Nearly all the  $P^{32}$  remains in the planchet, while nearly all the  $S^{32}$  burns. The

$\beta^-$  activity on the planchet increases linearly with the number of grams burned on the planchet. Therefore, there is no need to burn the whole sample if enough counts per minute are reached to enjoy good statistics before burning the full 800 grams.

**2.3.2 Neutron Film.** Nuclear track films are photographic films especially prepared to show proton tracks in the emulsion. The protons are evolved by two mechanisms; the first being the  $N^{14}(n, p) C^{14}$  reaction caused by thermal neutrons and the second being hydrogen recoils caused by fast neutrons. Protons travelling through the thick emulsion leave dense tracks that can be counted under a microscope. The films used were the Kodak personal neutron-monitoring films, Types A and B. The Type A film was known for many years as Kodak nuclear-track dental-size film, Type NTA. The Type B badge contains two pieces of film and two sheets of aluminum in

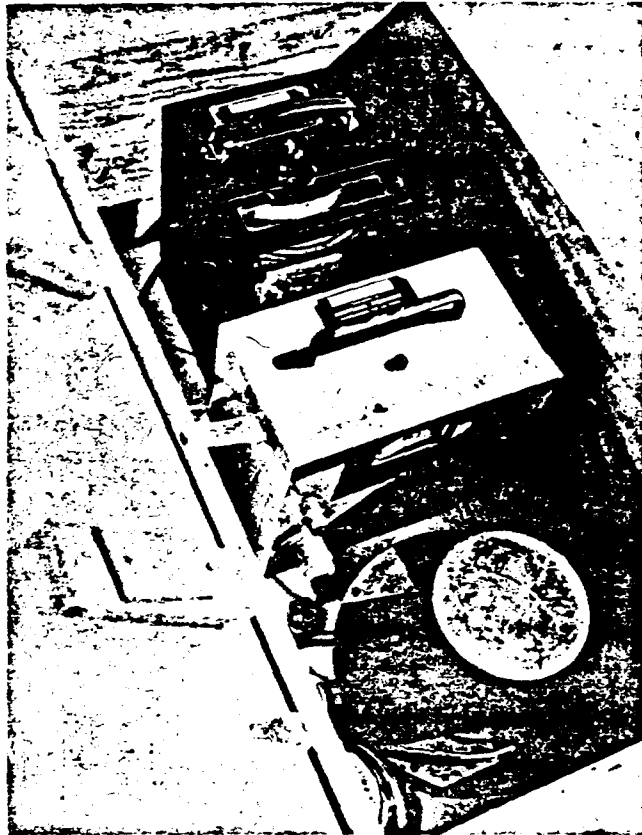
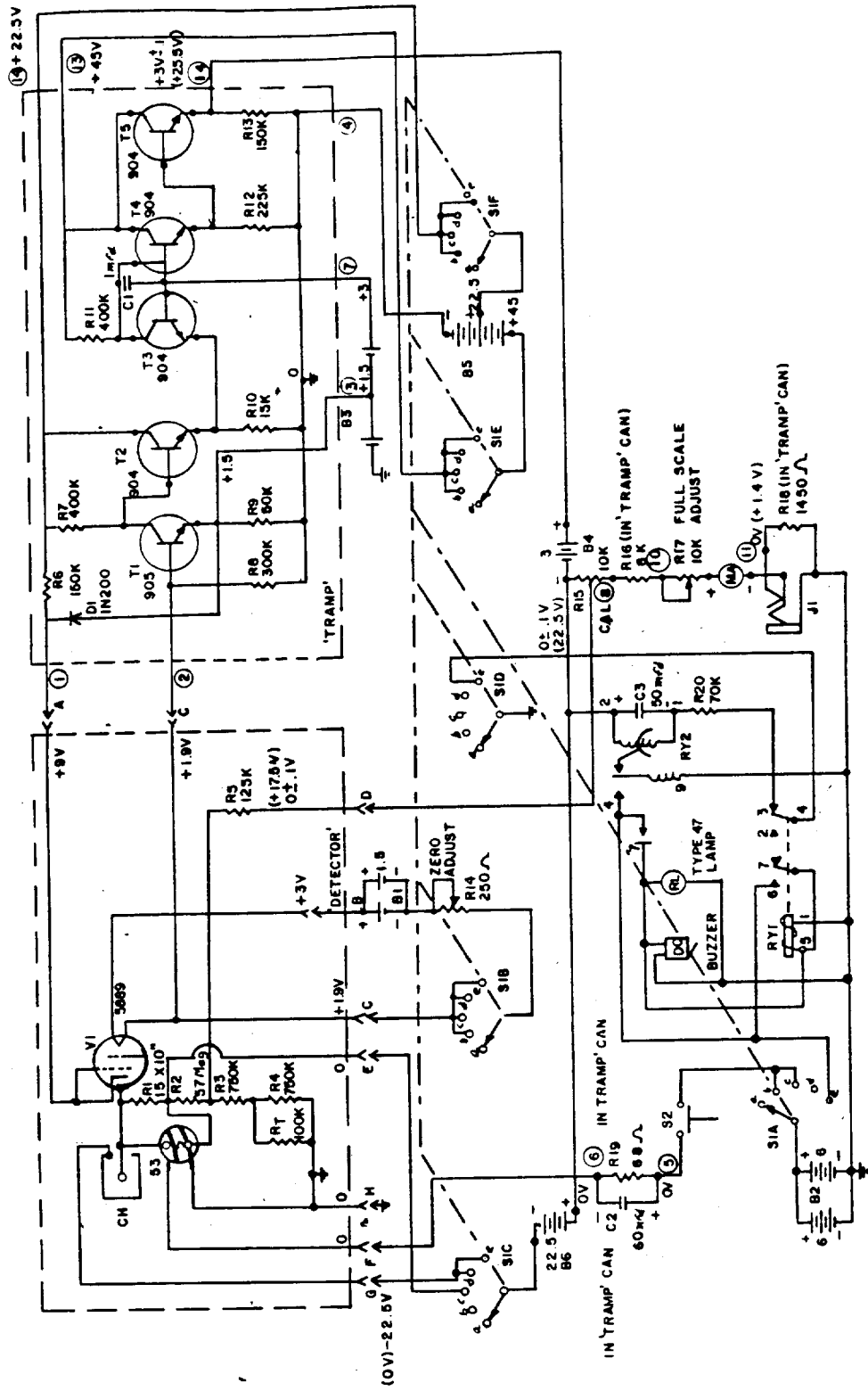

Figure 2.13 Fallout detector (MG-3), showing detector, indicating, and recording units.

addition to the packaging material. Aluminum shields and cellulose radiators make the nuclear-track population a measure of dose, independent of energy. The films were returned to AFSWC for processing and counting of the proton tracks. Figure 2.16 shows the calibration curves, derived from exposing both sulfur and Types A and B films at the Los Alamos Godiva.

**2.3.3 RTF Dosimeters.** Resonance-threshold foil (RTF) personnel neutron dosimeters were exposed at six locations as indicated in Table 2.1 and Figure 2.3. The dosimeter case was 2-S aluminum, 0.102-inch thick. The aluminum case housed three sets of indium foils. Each set of foils was in a package of three 0.003-inch-thick disks, approximately 0.625 inch in diameter. One set of the indium foils was unshielded, and was activated by neutrons up to 0.1 kev. The second group of foils was covered with 0.010-inch-thick cadmium disks. Only neutrons with an energy greater than the cadmium cutoff (0.5 ev for the thickness used) could activate the indium.



'INDICATOR AND POWER SUPPLY'

Figure 2.14 Detector and indicator of MG-3.

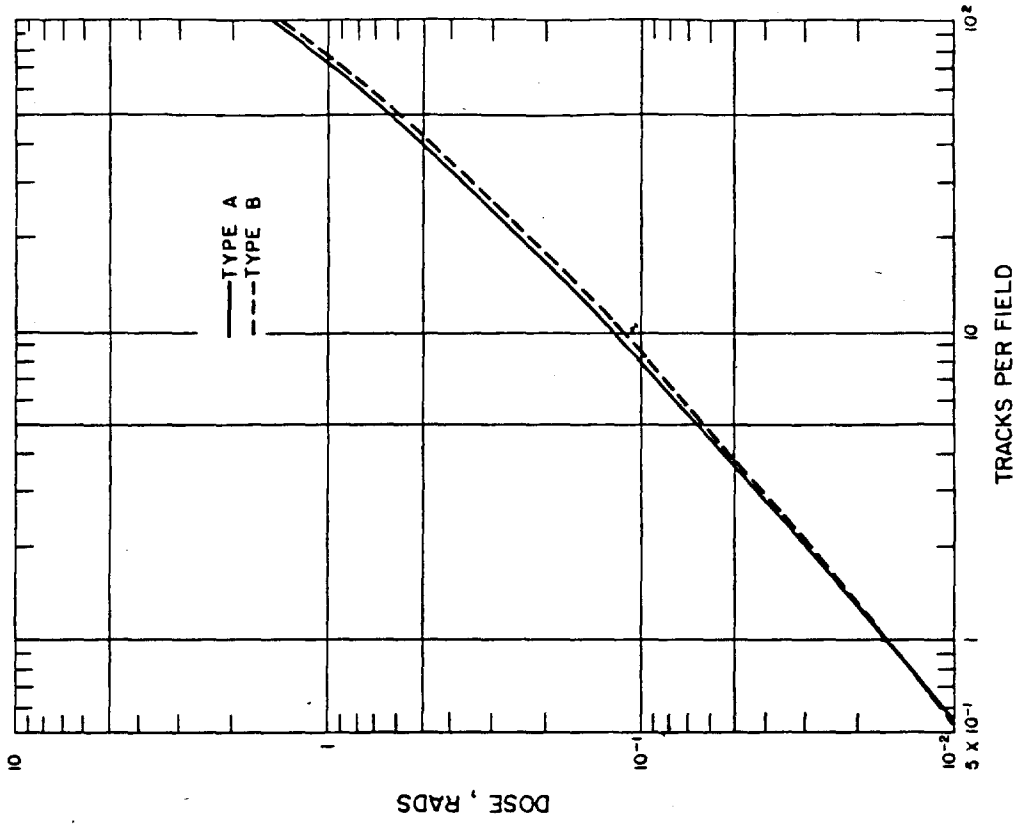

Figure 2.16 Calibration for neutron films, rad versus tracks per field.

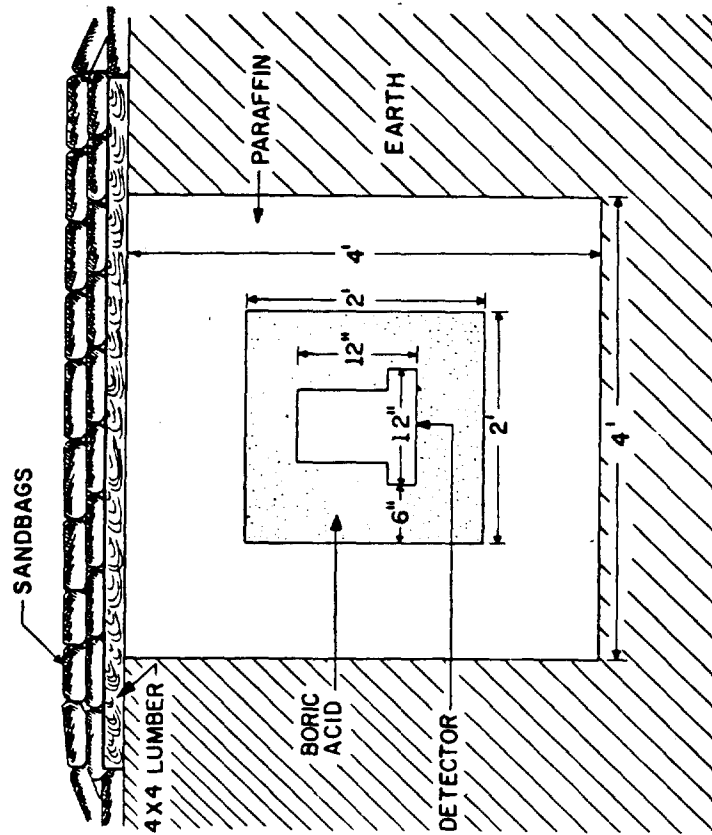

Figure 2.15 MG-3 detector installation.

TABLE 2.2 CALIBRATION AND READING OF INSTRUMENTATION

Instruments	Where Calibrated	Where Processed	Where Read
Kaiser Dose Rate	LASL	—	AFSWC
NBS Film Packs	EG&G and AFSWC	AFSWC	AFSWC
Kodak 548-0 Film	EG&G	AFSWC	AFSWC
LSD Film Stacks	LSD*	LSD	LSD
LSD Film Packs	LSD	LSD	LSD
Glass Needles	NYNS†	NYNS	NYNS
DT-60	LASL	—	NTS
Dose Rate	LASL	—	AFSWC
Type A Neutron Film	LASL	AFSWC	AFSWC
Type B Neutron Film	LSD	LSD	AFSWC
RTF Dosimeter	LASL	—	NTS
Sulfur Planchets	LASL	AFSWC	AFSWC
Sulfur Bags	LASL	AFSWC	AFSWC
Mg-3	Tech Opst‡	—	AFSWC

\* Lexington Signal Depot

† New York Naval Shipyard

‡ Technical Operations Inc., Arlington, Massachusetts

The third foil packet, shielded by cadmium covered polyethylene disks, was provided to detect neutrons in the intermediate energy range. These dosimeters were mounted against a 10-by-12-by-6-inch paraffin block to simulate the response when worn on the body.

The RTF dosimeters were recovered 7 minutes after detonation. The foil activations were determined with an Anton pancake mica-end-window tube (1007TA) and a Model 192 Nuclear Chicago ultrascaler.

#### 2.4 DATA REQUIREMENTS

The data required included: (1) gamma dose rate as a function of time and distance until approximately H + 20 seconds at the earth surface; (2) total gamma dose as a function of distance; (3) neutron dose as a function of distance; (4) fallout as a function of time at a given distance; (5) neutron-induced activity decay rate of NTS soil; and (6) rate of rise of fireball during time-dose-rate measurements. The instruments were calibrated, processed, and read as shown in Table 2.2.

## Chapter 3

# RESULTS and DISCUSSION

The calculated relative air density at Frenchman Flat for Shot Hamilton was 0.875, using ICAO atmosphere as standard (15 C and 760 mm Hg). The radiochemical yield measured by LASL was  $1.17 \pm 0.06$  tons. This nuclear yield of about 1 ton was a twentieth of that expected; as a result, all measurements were an order of magnitude lower than those anticipated during the planning period before the shot—a significant fact in interpreting this data.

Where applicable, the total-dose measurements are presented as dose times slant distance squared versus slant distance from ground zero with no corrections for relative air density. Shot Hamilton was detonated on a 50-foot wooden tower.

### 3.1 INITIAL-GAMMA DOSE RATE

Data for initial-gamma dose rate was obtained at two of the three stations. No data was obtained by the instrumentation at 425 yards from ground zero. The reason for the failure of the instrument is not known. Dose rate versus time for the remaining two stations is presented in Figures 3.1 and 3.2. The experimental and corrected data is presented in Table 3.1. The dose rate data in these figures was corrected for fireball rise, taking into consideration the increase in slant range from the detectors to the fireball (or cloud). The resulting dose rates are then those that would be received from a stationary source. The data necessary to make the corrections for fireball rise was obtained from an EG&G film of the detonation. Analysis of the film showed that the fireball rise could be represented by:

$$h_c = 23.5 t^{0.7}$$

where  $h_c$  is the cloud height in yards and  $t$  is the time after the detonation in seconds.

The curves for dose rate versus time obtained at both 550 and 750 yards exhibited a pronounced leveling off beyond  $H + 10$  seconds (Figures 3.1 and 3.2). This effect resulted from a characteristic of the instruments utilized for the measurements. To ensure successful documentation of the high dose rates anticipated in the time interval prior to 0.1 second for the planned yield and to provide the necessary response time, the output frequency range of the blocking oscillator circuit was raised (Section 2.2.1). This resulted in raising the lower threshold of the instrument and caused the output frequency of the blocking oscillator circuit to gradually level off as the dose rates being measured passed through this threshold. The decrease in actual yield from the anticipated yield by a factor of twenty resulted in the lower threshold of the instruments being reached by both of the instruments before the entire +40-second time interval, which was to be documented, had elapsed. Consequently, the measured dose rates at 750 yards from ground zero lower than  $1.5 \times 10^{-2}$  r/sec and those at 550 yards lower than  $5 \times 10^{-2}$  r/sec were higher than the actual intensities that reached those points.

An estimate of the probable decay from Shot Hamilton can be made by arbitrarily matching the curve for intensity of the measured dose rate obtained at 750 yards with the curve obtained from Shot Lassen, Operation Plumbbob, (Reference 4) at 1 second (Reference 16). Figure 3.1 shows the manner in which the measured dose rate probably would have decayed, indicated by the Lassen data points, had the instruments' threshold not been reached. The excellent agreement between the two curves above  $1.5 \times 10^{-2}$  r/sec is apparent. A theoretical estimate of dose rate versus time using data provided in AFSWC TR-58-13 is also indicated on Figure 3.1.

Figure 3.2 shows the gamma dose rate versus time measured at the 550-yard location, along

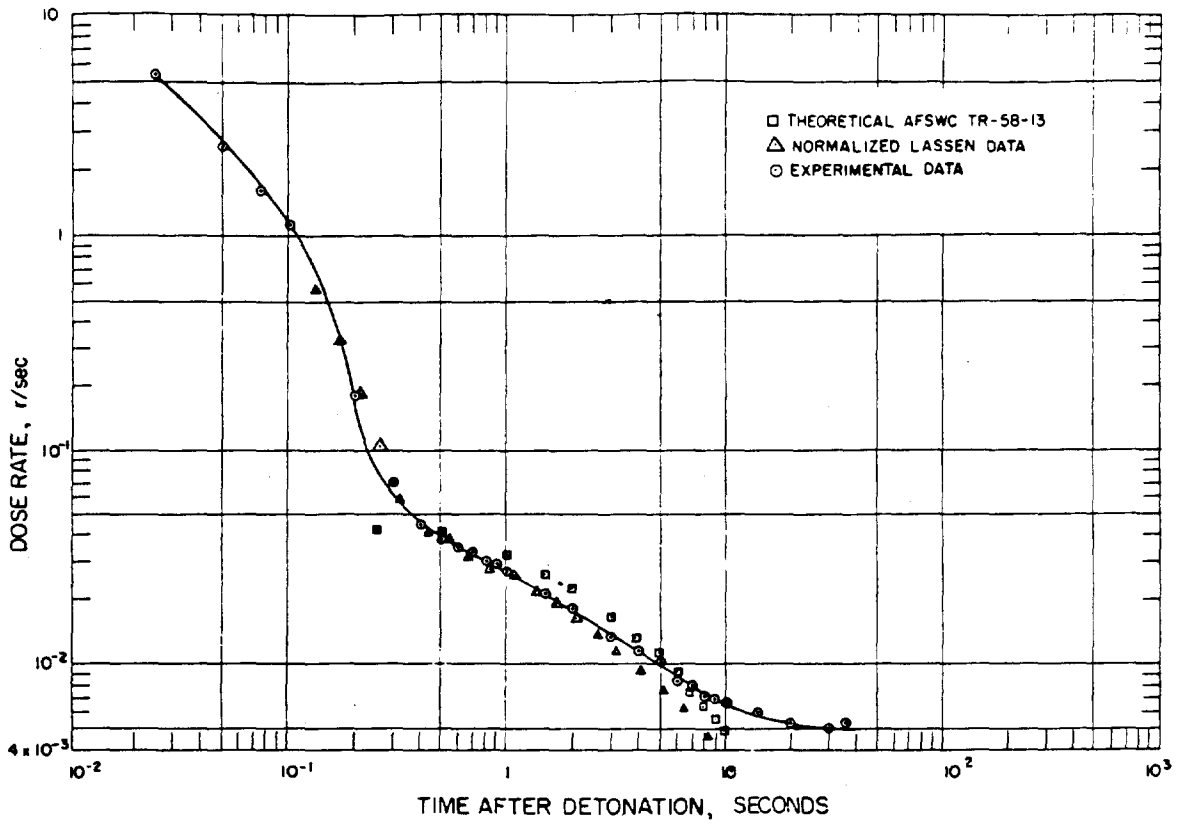

Figure 3.1 Initial-gamma dose rate versus time at 750 yards, 85-degree axis.

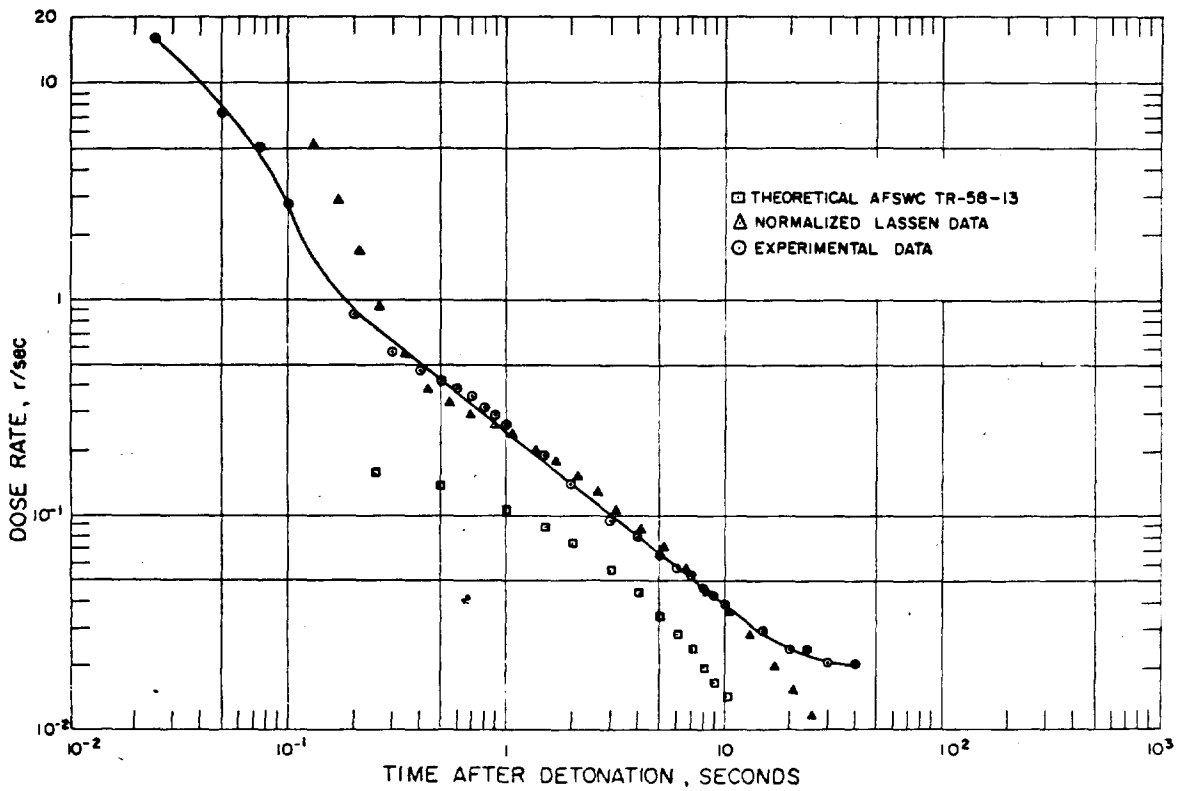

Figure 3.2 Initial-gamma dose rate versus time at 550 yards, 85-degree axis.

with the data from Shot Lassen normalized in the same manner as was done for the 750-yard data. The theoretical estimate of AFSWC TR-58-13 is also shown.

The break in the curve, that is, the point at which the nitrogen-capture effect disappears and the fission-product portion of the curve predominates, appears normally at about 0.4 seconds. The appearance of this break in the data obtained at 550 yards at approximately 0.2 second makes the time scale of this instrument suspect. As dependence on tape speed was the only time reference utilized this error was entirely possible.

Figure 3.3 shows the measurements obtained at 750 yards, along with the Lassen data normalized as was done previously at 1 second. The measurements obtained at 550 yards are also plotted in Figure 3.3; however, a constant multiplier of two was used to shift the time axis of the

TABLE 3.1 INITIAL-GAMMA DOSE RATE VERSUS TIME

550 Yards			750 Yards		
Time	Experimental Dose Rate	Corrected Dose Rate	Time	Experimental Dose Rate	Corrected Dose Rate
sec	r/sec	r/sec	sec	r/sec	r/sec
0.025	16.1		0.025	5.36	
0.05	7.36		0.05	2.58	
0.075	5.11		0.075	1.61	
0.1	2.77		0.1	1.12	
0.2	0.861		0.2	0.180	
0.3	0.569		0.3	0.0703	
0.4	0.472		0.4	0.0450	
0.5	0.424		0.5	0.0383	
0.6	0.389		0.6	0.0347	
0.7	0.356		0.7	0.0328	
0.8	0.317		0.8	0.0299	
0.9	0.292		0.9	0.0289	
1.0	0.264	0.265	1.0	0.0269	0.0270
1.5	0.186	0.187	1.5	0.0214	0.0215
2	0.142	0.143	2	0.0181	0.0182
3	0.0944	0.0958	3	0.0133	0.0134
4	0.0778	0.0796	4	0.0114	0.0116
5	0.0639	0.0659	5	0.0103	0.0105
6	0.0556	0.0579	6	0.0083	0.0085
7	0.0503	0.0529	7	0.00778	0.00803
8	0.0439	0.0466	8	0.00694	0.00721
9	0.0394	0.0429	9	0.00667	0.00698
10	0.0350	0.0390	10	0.00639	0.00673
15	0.0253	0.0297	14	0.00556	0.00605
20	0.0197	0.0246	20	0.00472	0.00541
22	0.0192	0.0245	30	0.00403	0.00512
30	0.0144	0.0210	36	0.00397	0.00539
40	0.0122	0.0209			

data and the intensity was decreased to match the 750-yard measurements at 1 second. The intensities out to 20 seconds no longer suffer from the instrumentation error and follow the Lassen data with close agreement.

Figure 3.4 shows the percent of the measured initial-gamma dose accumulation as the function of time at the 750-yard location. The heavy line in the figure shows the unrealistically steep approach to 100 percent that results from the leveling off of the measured data. If a decay similar to that of Shot Lassen is assumed, the dashed line illustrates the integrated gamma dose under these conditions.

As a result of the measurements obtained, the shape of the curve for fission-product dose-rate decay for very-low-yield weapons was further defined. The agreement between data obtained from Operation Plumbbob (Shot Lassen) and the adjusted data obtained from Shot Hamilton was found to be good. As the total dose can be accurately predicted and the fraction of the initial

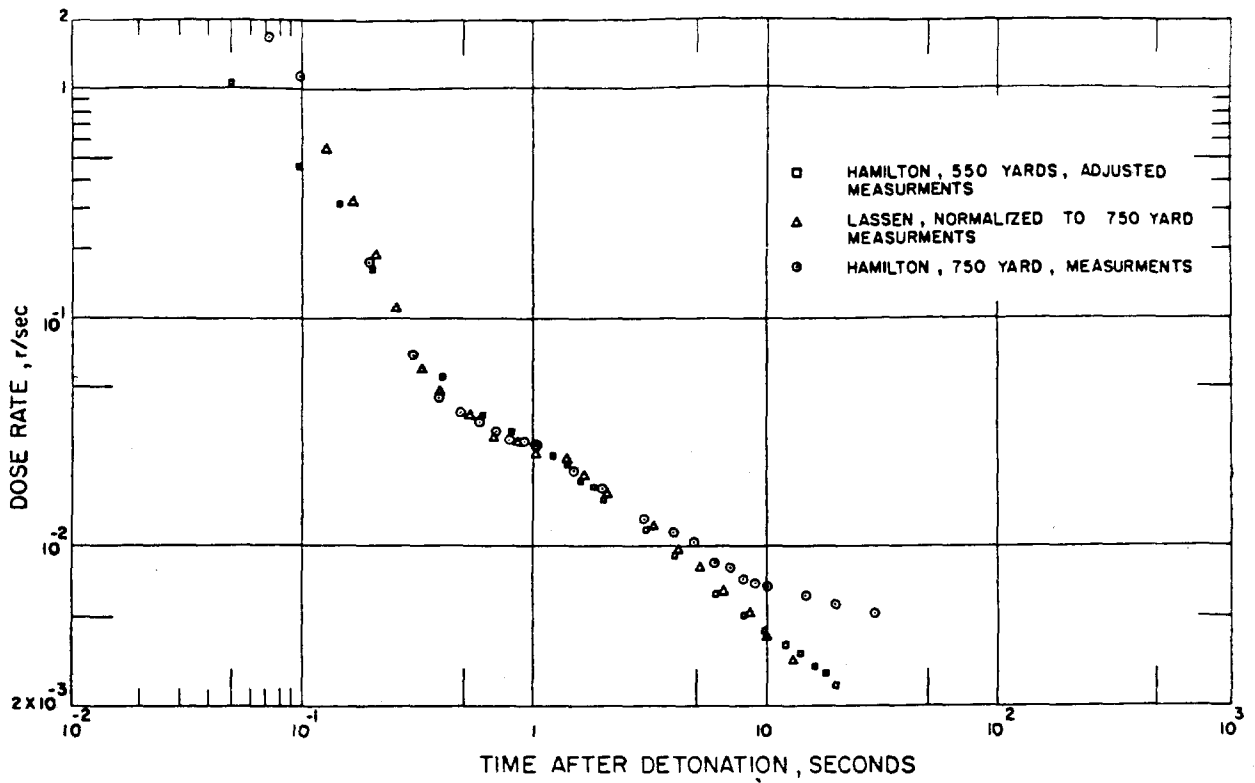

Figure 3.3 Summary of dose-rate data.

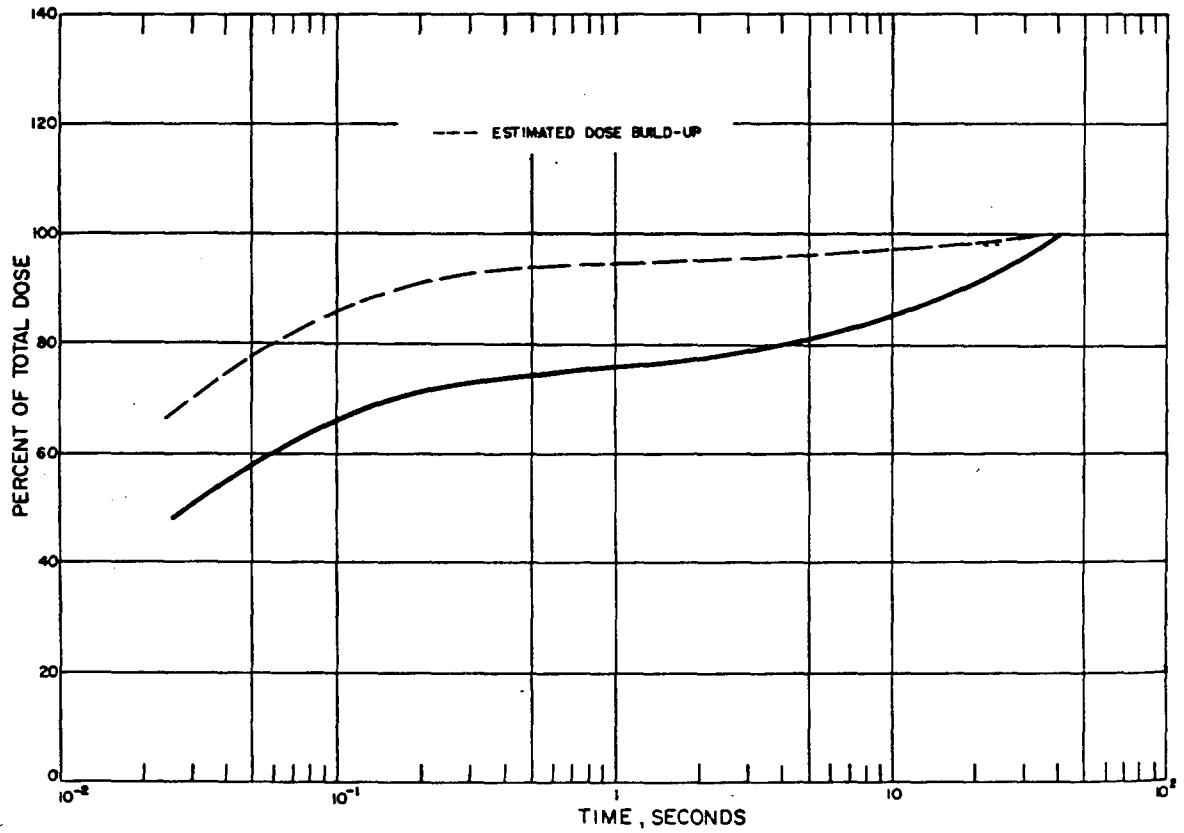

Figure 3.4 Integrated initial-gamma dose percent of total dose versus time, 750 yards.

gamma dose attributable to fission-product decay is known, the shape of the decay curve is sufficient to provide reasonably accurate information on dose rate versus time for weapons of the measured yield and certainly can be extended safely to weapon yields of 20 tons.

### 3.2 TOTAL INITIAL-GAMMA DOSE

Measurements were taken from 55 to 1,600 yards along the high-neutron axis (0 degrees) and

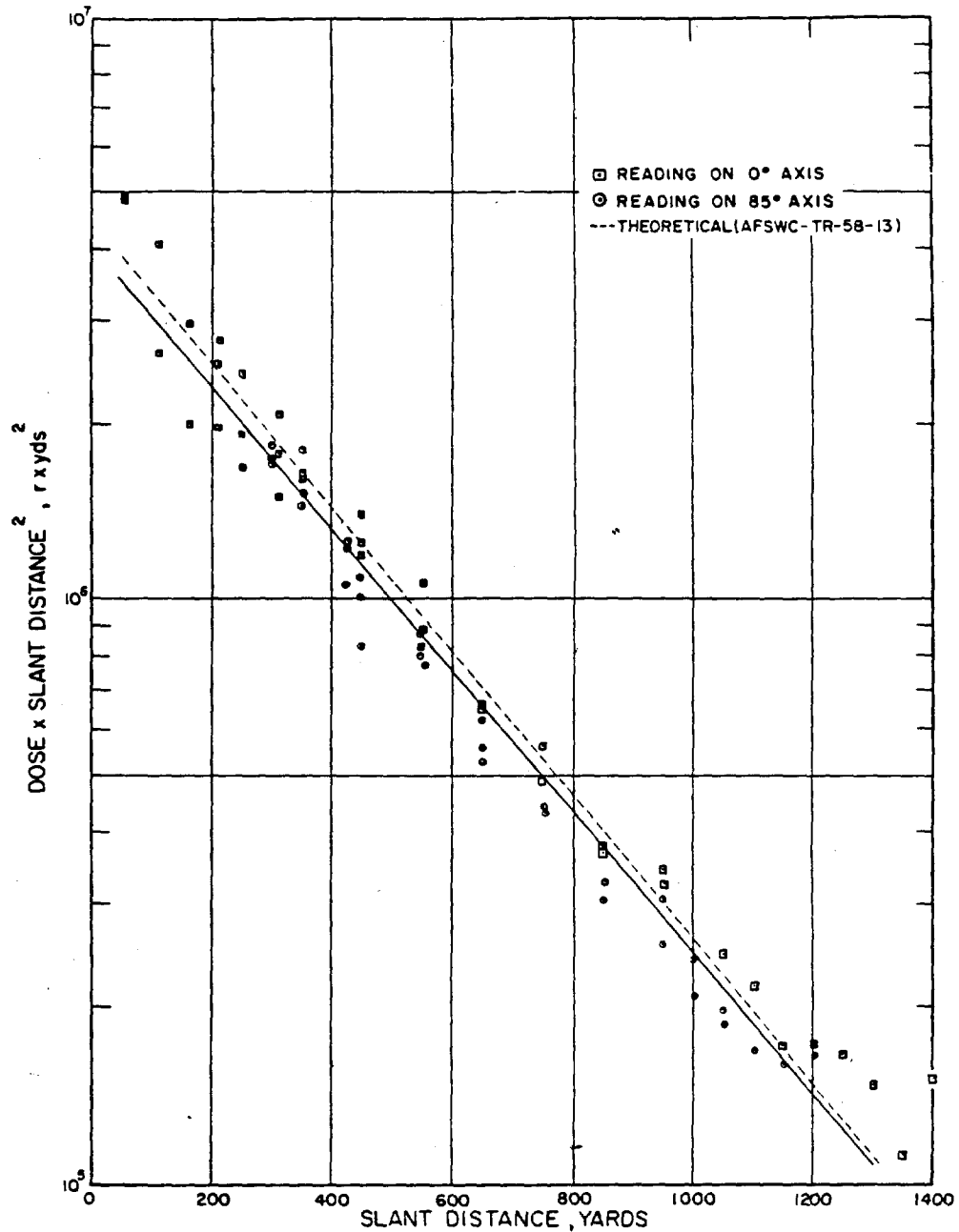

Figure 3.5 Summary of initial gamma,  $RD^2$  versus  $D$ .

from 300 to 1,600 yards along the low-neutron axis (85 degrees) at station locations as indicated in Figure 2.3 and Table 2.1.

Uncorrected and corrected (where applicable) data for initial-gamma dose as a function of distance are presented in Tables 3.2 and 3.3 for all total-gamma-measuring techniques utilized. In most cases there was more than one of each of the detectors per station. When this occurred, the average reading for each type of detector appears in Tables 3.2 and 3.3.

TABLE 3.2 INITIAL-GAMMA DOSE VERSUS SLANT DISTANCE, 0-DEGREE AXIS

Dose, roentgens.								
Slant	NBS Holders		LSD Packs	LSD Stacks		DT-60s		Glass Needles
Distance	Uncorrected	Corrected	Uncorrected	Uncorrected	Corrected	Uncorrected	Corrected	Uncorrected
yd								
55	2,000	1,624	3,000	2,000	1,624	—	—	995
110	420	340	600	300	220	—	—	276
160	147	117	210	108	78	—	—	—
210	73	58	125	60	45	70	65.7	55
250	40	31	59	36	27	42	39.3	38
310	20.6/19.9*	15.9/15.2	30/52*	18.5/28.0*	13.8/23.3	23.2	21.8	23/21*
350	15.7/16.8	12.5/13.6	21/31*	14/18	10.8/14.8	13.5	12.6	17/12*
450	7.1/7.4	6.0/6.3	7.6/13.1	7/7	5.9/5.9	7.37	6.95	11
550	3.4/3.6	2.8/3.0	4.2/6.1	3.8/3.4	2.95/2.55	3.75	3.55	9
650	1.9/2.0	1.54/1.58	1.82/2.46	1.85/2.05	1.44/1.64	2.71	2.71	—
750	1.13	1.00	1.55	1.0	0.87	—	—	—
850	0.59	0.52	0.68	0.58	0.51	—	—	—
950	0.38	0.38	0.47	0.36	0.36	—	—	—
1,050	0.31	0.31	0.255	0.225	0.225	—	—	—
1,100	0.26	0.26	0.175	0.180	0.180	—	—	—
1,150	0.18	0.18	0.155	0.130	0.130	—	—	—
1,200	—	—	0.130	0.120	0.120	—	—	—
1,250	—	—	0.100	0.115	0.115	—	—	—
1,300	—	—	0.073	0.088	0.088	—	—	—
1,350	—	—	0.043	0.066	0.066	—	—	—
1,400	—	—	0.036	0.077	0.077	—	—	—
1,450	—	—	0.043	0.088	0.088	—	—	—
1,500	—	—	0.029	0.044	0.044	—	—	—
1,550	—	—	0.022	0.044	0.044	—	—	—
1,600	—	—	0.014	0.033	0.033	—	—	—

\* First number refers to dosimeter inside steel pipe and second number to those outside.

TABLE 3.3 INITIAL-GAMMA DOSE VERSUS SLANT DISTANCE, 85-DEGREE AXIS

Dose, roentgens.								
Slant	NBS Holders		LSD Packs	LSD Stacks		DT-60s		Glass Needles
Distance	Uncorrected	Corrected	Uncorrected	Uncorrected	Corrected	Uncorrected	Corrected	Uncorrected
yd								
300	23	19.4	41.8	23.0	19.4	22.2	20.6	17
350	14.6	12.4	27.5	14.0	11.8	15.8	14.8	15
425	7.9	6.75	13.0	7.0	5.85	7.5	7.0	9
450	6.3	5.38	10.0	5.9	4.98	4.5	4.1	—
550	3.3	2.88	4.80	3.05	2.63	2.75	2.55	—
650	1.54	1.32	2.08	1.70	1.48	1.25	1.25	—
750	0.88	0.77	1.05	0.88	0.77	—	—	—
850	0.51	0.46	0.60	0.48	0.42	—	—	—
950	0.34	0.34	0.36	0.28	0.28	—	—	—
1,000	0.24	0.24	0.265	0.21	0.21	—	—	—
1,050	0.17	0.17	0.200	0.18	0.18	—	—	—
1,100	—	—	0.150	0.140	0.14	—	—	—
1,150	—	—	0.108	0.120	0.12	—	—	—
1,200	—	—	0.085	0.115	0.115	—	—	—
1,250	—	—	0.065	0.110	0.110	—	—	—
1,300	—	—	0.035	0.077	0.077	—	—	—
1,350	—	—	0.029	0.055	0.055	—	—	—
1,400	—	—	0.014	0.077	0.077	—	—	—
1,450	—	—	0.014	0.033	0.033	—	—	—
1,500	—	—	0.007	0.033	0.033	—	—	—
1,550	—	—	0.004	0.033	0.033	—	—	—
1,600	—	—	0.004	0.044	0.044	—	—	—

Figure 3.5 is a composite of the measurements made with the DT-60/PD dosimeters, NBS film packs, and LSD film stacks. Each datum point is the numerical average of the corrected readings obtained by a particular dosimeter technique at the slant distance indicated. The NBS and LSD data obtained along the 0-degree axis was plotted without distinguishing between dosimeters placed in pipes or on stakes, because all films were calibrated both inside and outside of the pipes. The DT-60's were probably not sensitive enough to record these differences; therefore, data obtained in pipes and at stake stations were plotted the same as the films. The line drawn is a least-squares fit of the data points shown.

The measurements along the 0-degree axis are consistently higher than along the 85-degree axis. The slightly higher dose (10 to 15 percent) on the high-neutron axis is, for the most part, attributable to the increased nitrogen-capture gamma dose on this axis. The weapon orientation and a 4-inch-thick, 11-inch-diameter beryllium shadow shield adjacent to the weapon on the 85-degree axis accounted for the higher neutron output on the 0-degree axis. Also presented in Figure 3.5 is a theoretical curve for initial-gamma dose (Reference 6) obtained by assuming a 0.001-kt detonation and a relative air density (NACA atmosphere) of 0.88. Using TM-23-200 (Reference 17) and a relative air density of 0.9 the theoretical dose is approximately a factor of two lower than the experimental measurements shown in Figure 3.5.

No corrections were applied to the total-dose measurements in Figure 3.5 for the increased radiation dosages actually recorded, because of neutron-induced activity present in the soil and in the pipes in which the close-in dosimeters were placed. Also, no corrections were made for any dosages received from fallout. The cable to which the standard 3-inch-steel-pipe holders were attached was drawn back beyond 500 yards at approximately H + 5 minutes. The film badges and associated equipment were removed from the pipes within 30 minutes after shot time. Dose-rate measurements on each pipe were negligible, except for the one at 55 yards for which the dose rate was only 1 r/hr at approximately 5 minutes after the shot. Dose rates from fallout at distances greater than 300 yards were negligible. Film badges and associated equipment attached to stakes beyond 300 yards were removed within 2 hours after shot time. On this basis, it is believed that any dose received by the detectors other than initial-gamma dose was negligible.

The NBS and LSD data presented in Figure 3.5 was corrected for the contribution of the neutrons to the film blackening. This effect can be attributed to both the low-energy neutrons and to the total neutron rep dose resulting primarily from the higher-energy neutrons. Experiments that have measured these effects have shown that little error is introduced in the range of useful film exposure by assuming an average film type and using a single correction factor for each effect on the films. The total initial gamma dose film data points for a particular slant distance as shown in Figure 3.5 were derived from the following equations:

$$r \text{ dose} = \text{film reading} - \left[ \frac{\text{gold neutron flux}}{3.5 \times 10^9 \text{ n/cm}^2} + 0.038 (\text{neutron rep dose}) \right]$$

The corrections used were (Reference 5): film sensitivity to gold neutrons,

film R, and film sensitivity to high-energy neutrons as a percentage of neutron rep dose,  $3.8 \pm 2.4$ .

The gold neutron flux for the 0-degree axis was obtained from Reference 18. No gold flux measurements were made along the 85-degree axis; consequently this correction to the measured film dose was based on the 0-degree-axis gold measurements. The rep dose used in the corrections was based on the sulfur-activation measurements as presented in Figures 3.6 and 3.7.

The DT-60/PD dosimeter data presented in Figure 3.5 was corrected for the effect of neutrons on the dosimeter reading. The DT-60/PD dose as read by the reader is:

$$\text{Reader dose} = \text{true dose} + 6.8 n^{\text{th}}$$

where  $n^{\text{th}}$  is the neutron rep dose at a particular slant range due to thermal neutrons, and 6.8 is an experimentally determined coefficient (Reference 19). The thermal (gold) neutron flux was obtained from Reference 18 and was converted to dose using the factor

The gold flux as measured on the 0-degree axis was used to correct the DT-60/PD measurements on both axes. The measured and corrected DT-60/PD doses are presented in Tables 3.2 and 3.3.

The gamma doses measured with the glass-needle dosimeters (read by the New York Naval Shipyard) are presented in Tables 3.2 and 3.3. Each reading is the numerical average of eight individual readings at a particular slant range. The measurements obtained with these dosimeters were generally a factor of two lower than the data in Figure 3.5 and had considerable scatter; for that reason they were not presented in Figure 3.5. The doses recorded beyond 400 yards were higher than those presented in Figure 3.5. The response of the glass needles is not linear with energy and is higher at low energies. Although the high energy response has not been fully investigated, the lead shield in which the needle was exposed was probably not sufficiently thick to make the needle response as high as it should be. Because of the lack of time prior to the

field exposure, the pre-dose reading of the individual needles was not established. The background reading applied to all the needles was obtained by averaging the readings of 25 unexposed needles. The range of the unexposed needle readings was 30 to 40 r (Reference 20).

The total initial-gamma doses measured with the LSD film pack are presented in Tables 3.2 and 3.3. These measurements were consistently higher than those obtained at corresponding distances using the LSD stack or NBS film. The holder in which the films were placed did not make the film response independent of energy. As only  $\text{Co}^{60}$  and  $\text{Ra}^{226}$  were used for calibration, the very-high-energy gammas released with the nitrogen-capture phase of the initial gamma radiation were not accounted for during calibration (Reference 21). For this reason, this data was not used in the preparation of Figure 3.5.

*Pages 38 thru 41 Deleted.*

### 3.4 NEUTRON-INDUCED ACTIVITY

The MG-3 detector head buried at 30 yards from ground zero operated satisfactorily. Dose rate versus time was obtained for 12 minutes after time zero. The dose rate beyond this time was below the sensible threshold of the instrument (0.1 r/hr).

Figure 3.11 shows that the gamma radiation decayed according to the equation  $y = at^{-b}$  after 0.4 minute, where  $y$  was the dose rate in roentgens per hour, and  $t$  was the time in minutes. The constants in this equation were  $a = 2.89$  and  $b = 1.21$ . These were determined from a least-squares fit of the data points. The decay exponent of  $-1.21$  suggests that the detector was measuring fission-product decay, rather than neutron-induced activity in the soil. Thus, it is believed that close to ground zero the radiation level from induced activity of the soil was insignificant when compared to that from fission products.

As mentioned in Section 2.2.5, the detector head was buried below ground in boric acid and paraffin to minimize neutron-induced activity in the head itself. From all indications, it is certain that there was no activation of the detector head.

Calibration of the chart recorder indicated that the chart read within  $\pm 1$  percent of the detector reading and that the lag time of the chart needle was less than 1 second. Thus the decay recorded was the actual decay of the radioactivity above ground.

### 3.5 FIELD TEST OF MG-3

The fallout-radiation dose rate at the far-out MG-3 station (650 yards, 85-degree axis) was never high enough to be recorded by the chart recorder (0.1 r/hr). However, the close-in MG-3 did operate satisfactorily (Section 3.3). On this basis, it is believed that the field testing of the MG-3 fallout detector was a success.

## *Chapter 4*

# **CONCLUSIONS and RECOMMENDATIONS**

### **4.1 CONCLUSIONS**

Histories were obtained for initial-gamma dose rate at 550 and 750 yards from ground zero until the intensity fell below the lower recording threshold of the instruments. After adjusting the measured data, agreement was obtained with Lassen data from Operation Plumbbob and computed data obtained from the existing theoretical technique.

The measurements of total-initial-gamma dose were in substantial agreement with theoretical predictions. The present methods of predictions for fractional-kiloton weapons appear valid. At 110 yards, an average dose of 243 r was measured; at 310 yards, 18 r was measured.

The neutron-induced activity at 30 yards from ground zero was negligible when compared to dose rates from fission product decay.

The field test of a prototype of the standard Air Force gamma-radiation-fallout detector (designated MG-3) was successful.

### **4.2 RECOMMENDATIONS**

With the increasing importance of fractional-kiloton warheads in the weapon inventory, additional measurements of initial-gamma dose rate versus time from a full-scale yield of proposed warheads would be highly desirable.

15. C.S. Cook and others; "Neutron-Induced Activities in Soil Elements"; Project 2.2, Operation Plumbbob, WT-1411, July 1959; U.S. Naval Radiological Defense Laboratory, San Francisco 24, California; Secret Restricted Data.
16. E.N. York; Private Communication; Boeing Aircraft Corporation.
17. "Capabilities of Atomic Weapons"; TM 23-200, Page 4 - 12, November 1957; Armed Forces Special Weapons Project, Washington, D. C.; Confidential.
18. David L. Rigotti; "Nuclear Radiation from Very-Low-Yield Bursts"; Project 2.12, Operation Hardtack II, ITR-1680, December 1958; Chemical Warfare Laboratories, Army Chemical Center, Maryland; Secret Restricted Data.
19. E.R. Ballinger; Private Communication; Los Alamos Scientific Laboratory, Los Alamos, New Mexico.
20. R.C. Riggin; Private Communication; New York Naval Shipyard.
21. C. Slover; Private Communication; Lexington Signal Depot, Lexington, Kentucky.
22. "The Nuclear Radiation Handbook"; AFSWP-1100, Page 126, March 1957; Secret Restricted Data.