

Declassified  
DOD DIR 5200.10

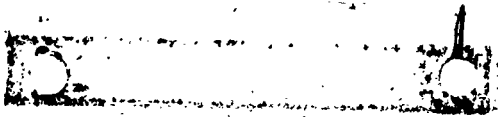

~~SECRET~~

17870  
Declassified  
DOD DIR 5200.10

# HEADQUARTERS TASK GROUP 7.4



Declassified  
DOD DIR 5200.10

## OPERATION ORDER NO. 8-54

HOWELL M. ESTES, JR.  
BRIGADIER GENERAL, USAF  
COMMANDER

Declassified  
DOD DIR 5200.10



Declassified  
DOD DIR 5200.10

This Document Consists Of  
25 PAGE(S) No. 100  
117 Copies A Series

3-3577S

Declassified  
DOD DIR 5200.10

Declassified  
DOD DIR 5200.10

Declassified  
DOD DIR 5200.10

~~SECRET~~  
HEADQUARTERS  
TASK GROUP 7.4, PROVISIONAL  
APO 187, c/o Postmaster  
San Francisco, California  
1 May 1954, 1800M

OPERATIONS ORDER NO. 8-54

CHART REFERENCES:

- a. World Aeronautical Charts (748, 749, 848, 849, 850) 1:1,000,000.
- b. USAF Aeronautical Planning Chart (AP-14) 1:5,000,000.

TASK ORGANIZATION:

- a. Headquarters, Task Group 7.4,  
Provisional Brigadier General Howell M. Estes, Jr.
- b. Test Aircraft Unit Lt Colonel James A. Watkins
- c. Test Services Unit Lt Colonel Mahlon E. Hammond
- d. Test Support Unit Colonel James F. Starkey

1. GENERAL SITUATION:

The mission covered by this Operations Order is assigned the code name YANKEE. Its execution day is Y-Day. Certain communications procedures, aircraft positioning in space at H-Hour and control procedures will be issued as annexes hereto not later than Y minus two days. This is a specific directive to all elements of the Air Task Group to execute their assigned missions in support of YANKEE. This order supplements Task Group 7.4 Operations Order 1-53 and 2-54 which are still in effect.

- a. See Annex A, Intelligence, TG 7.4 Operations Order 1-53.
- b. See Annex B, Organization and Command Relationships, TG 7.4 Operations Order 1-53.

- (1) Task Group 7.3 will provide, to Task Group 7.4, aircraft control facilities aboard the Command Ship and the Control Destroyer for the Y-Day event. (See Annex A, Check List, this Operations Order and Annex T, Command Ship CIC Procedures; Annex U, Control Destroyer Procedures, Operations Order 2-54.)
- (2) B-50 aircraft of the 97th Bomb Wing (Medium) will participate on Y-Day. (See Annex O, B-50 IEDA Flight Procedures, TG 7.4 Operations Order 2-54 and Annex A, Check List, this Operations Order).

2. MISSION:

To participate in the YANKEE Operation as directed by Joint Task Force SEVEN.

3. TASKS FOR SUBORDINATE UNITS:

- a. Test Aircraft Unit:

- (1) Execute assigned mission to include that specified in Annex A.

TASK GROUP 7.4  
OPRS ORDER NO. 8-54

~~SECRET~~

Declassified  
DOD DIR 5200.10

Declassified  
DOD DIR 5200.10

- 
- (2) Provide twelve (12) F-34 aircraft for necessary sampling missions for Y-Day. (See Annex H, Operations Order 2-54).
  - (3) Provide four (4) B-36 aircraft for control, effects and sampling missions for Y-Day. (See Annexes G, I, and K, TG 7.4 Operations Order 2-54).
  - (4) Provide one (1) B-47 aircraft for an effects mission on Y-Day. (See Annex J, TG 7.4 Operations Order 2-54).
  - (5) Integrate the operations of three (3) B-50 aircraft into Y-Day. (See Annex O, Operations Order 2-54).
  - (6) Assure adequate sample removal procedures for Y-Day. (See Annex R, TG 7.4 Operations Order 2-54).
  - (7) Augment the field maintenance facilities of the Test Support Unit as required.
  - (8) Provide for complete care, storage and issue of personal equipment to all air crews of the Test Aircraft Unit.
  - (9) Prepare the marshaling plan for all aircraft which will depart from ENIWETOK to participate in Y-Day, and special missions.
  - (10) Prepare a post mission parking plan for all aircraft that will land at ENIWETOK after the completion of their mission.
  - (11) Prepare a mission execution chart and assure that take-offs and landings are accomplished as specified in Annex C.
  - (12) Provide for aircraft decontamination.

b. Test Services Unit:

- (1) Execute assigned missions, including that specified in Annex A.
- (2) Provide three (3) C-54 photographic aircraft and crews for Y-Day. (See Annex L, TG 7.4 Operations Order 2-54).
- (3) Provide adequate SA-16 and other required SAR support to the AOC and CIC for operational control throughout the Y-Day mission. (See Annex F, TG 7.4 Operations Order 2-54).
- (4) Provide adequate WB-29 weather reconnaissance, cloud tracking and sampling services throughout the Y-Day mission. (See Annex M, TG 7.4 Operations Order 2-54).
- (5) Assure adequate pre-mission weather forecasting as required for the Y-Day mission.
- (6) Provide necessary weather briefings and weather reports to the CIC and AOC throughout the Y-Day mission.
- (7) Assure adequate communications facilities throughout the Y-Day mission.
- (8) Augment the field maintenance facilities of the Test Support Unit as required.
- (9) Coordinate with Test Aircraft Unit to assure that Test Services

TASK GROUP 7.4  
OPRS ORDER NO. 8-54

Declassified  
DOD DIR 5200.10 2



Declassified  
DOD DIR 5200.10

[REDACTED]  
Unit aircraft are marshaled as required by that Unit.

- (10) Provide for complete care, storage and issue of personal equipment to all aircrews of the Test Services Unit.

c. Test Support Unit:

- (1) Assure that transient traffic and airlift operations do not interfere with or endanger test aircraft operations during the Y-Day mission. (See Annex A, TG 7.4 Operations Order 2-54).
- (2) Provide two (2) C-47 aircraft for VHF relay for the Y-Day mission. (See Annex P, TG 7.4 Operations Order 2-54).
- (3) Establish required measures to prevent movement of vehicles from interfering with or endangering air operations throughout Y-Day.
- (4) Provide adequate crash removal and fire fighting protection for all air operations on Y-Day.
- (5) Place one (1) H-19 helicopter under the operational control of the SAR Element Commander and one (1) crash boat under the operational control of the AOC from 27 February 1954 and continuing throughout the project. (See Annex F, TG 7.4 Operations Order 2-54).
- (6) Assure adequate refueling and field maintenance support for all aircraft during the Y-Day mission.
- (7) Provide photographic coverage during Y-Day operations for historical purposes.
- (8) In coordination with other Test Units, assure adequate transportation schedules from the flight line to the dining halls and billeting areas throughout the Y-Day operations.
- (9) Coordinate with Test Aircraft Unit to assure that C-47 reflector aircraft are marshaled as required by that Unit.

x. All Units:

- (1) Provide Liaison Officers to assist Headquarters, TG 7.4 aircraft controllers in the AOC, on the Command Ship and Control Destroyer as required. (See Annex K, TG 7.4 Operations Order 1-53).
- (2) Coordinate with Test Support Unit to arrange required early dining schedules, in-flight lunches, transportation, etc., for the Y-Day mission.
- (3) Adhere to security procedures as outlined in Annex G, Security and Public Information, TG 7.4 Operations Order 1-53.
- (4) Emphasize the Flight Safety Program outlined in Annex L, Flight Safety, TG 7.4 Operations Order 1-53.
- (5) Be prepared to augment existing SAR facilities in emergencies during the Y-Day operation.
- (6) Be prepared to postpone execution of the mission for such

periods as are made necessary by adverse weather or other  
unforeseeable events. (See Annex V, TG 7.4 Operations  
Order 2-54).

- (7) Assure proper reporting of radiation encountered by multi-engine aircraft. (See Annex W, TG 7.4 Operations Order 2-54).
- (8) Conduct briefings as required. (See Annex X, TG 7.4 Operations Order 2-54).
- (9) Immediately after aircraft land maintenance personnel will clear all discrepancies as soon as possible so as to insure the aircraft are ready for departure in accordance with the Roll Up Plan.

4. LOGISTICAL MATTERS:

See Annex C, Administration, TG 7.4 Operations Order No. 1-53.

5. COMMAND AND SIGNAL MATTERS:

a. Communications: (See Annex E, TG 7.4 Operations Order 2-54).

b. Time: Zone "M" (Local) Time.

c. Command Posts:

- |                         |                                |
|-------------------------|--------------------------------|
| (1) Task Group 7.4      | USS ESTES (AGC-12)             |
| (a) Eniwetok Operations | Building #90, Eniwetok Island  |
| (2) Test Aircraft Unit  | Building #135, Eniwetok Island |
| (3) Test Services Unit  | Building #135, Eniwetok Island |
| (4) Test Support Unit   | Building #135, Eniwetok Island |

  
HOWELL M. ESTES, JR.  
Brigadier General, U. S. A. F.  
Commander

ANNEXES:

See Page 5

DISTRIBUTION:

See Page 6 and 7

ANNEXES

- A. Schedule of Events
- B. Aircraft Parking Plan
- C. Aircraft Mission Execution Chart
- D. Aircraft H-hour Positions and Flight Patterns
- E. Communications
- F. SAR Plan
- G. Control RB-36 Flight Procedures
- H. F-84 Sampler Flight Procedures
- I. B-36 Effects Flight Procedures
- J. B-47 Effects Flight Procedures
- K. B-36 Hi-Altitude Sampler Flight Procedures
- L. C-54 Photo Flight Procedures
- M. WB-29 Weather and Rad Safe Flight Procedures
- N. Decontamination Procedures
- O. B-50 IBDA Flight Procedures
- P. C-47 Flight Procedures
- Q. Observer Aircraft Flight Procedures
- R. Sample Recovery Procedures
- S. AOC Procedures
- T. CIC Procedures
- U. Control Destroyer Procedures
- V. Aircraft Abort Criteria
- W. Multi-Engine Aircraft Rad Safe Reporting Code
- X. Briefings
- Y. Navy Aircraft Flight Procedures

DISTRIBUTION LIST

<u>COPIES</u>	<u>COPY NO.</u>	<u>AIR FORCE AGENCIES</u>
1	1	C/S, USAF, Washington 25, D.C
1	2	DCS/Operations, Hq, USAF, Washington 25, D.C.
1	3	DCS/Personnel, Hq, USAF, Washington 25, D.C.
1	4	DCS/Materiel, Hq, USAF, Washington 25, D.C.
1	5	DCS/Development, Hq, USAF, Washington 25, D.C.
1	6	DCS/Comptroller, Hq, USAF, Washington 25, D.C.
1	7	Director of Plans, Hq, USAF, Washington 25, D.C.
2	8 - 9	Director of Operations, Hq, USAF, Washington 25, D.C.
1	10	AFOAT, DCS/Operations, Hq, USAF, Washington 25, D.C.
1	11	Director of Communications, Hq USAF, Washington 25, D.C.
3	12 - 14	Comdr, AFSWC, Kirtland AFB, New Mexico
3	15 - 17	Comdr, SAC, Offutt AFB, Nebraska
1	18	Comdr, ARDC, Baltimore, Maryland
1	19	Comdr, AMC, Wright-Patterson AFB, Ohio
1	20	Comdr, WADC, Wright-Patterson AFB, Ohio
1	21	Comdr, MATS, Andrews AFB, Washington 25, D.C.
1	22	Comdr, AACS, Andrews AFB, Washington 25, D.C.
1	23	Comdr, AWS, Andrews AFB, Washington 25, D. C.
1	24	Comdr, ARS, Andrews AFB, Washington 25, D. C.
1	25	Comdr, 8th Air Force, Carswell AFB, Texas
1	26	Comdr, PACDIVMATS, APO 953, c/o PM, San Francisco, Calif
1	27	Comdr, 4925th Test Group (ATOMIC), Kirtland AFB, NM
1	28	Comdr, 76th Air Rescue Sq, APO 953, c/o PM, San Francisco, Calif
1	29	Comdr, Air Defense Command, Ent AFB, Colorado
1	30	Comdr, Air Proving Ground Command, Eglin AFB, Fla
1	31	Comdr, 78th Air Rescue Sq, Box 26, FPO 824, c/o PM, San Francisco, Calif
1	32	Comdr, 15th Air Force, March AFB, Calif

JOINT TASK FORCE SEVEN AGENCIES

5	33 - 37	Comdr, JTF SEVEN, APO 187, c/o PM, San Francisco, Calif
5	38 - 42	Comdr, TG 7.1, APO 187, c/o PM, San Francisco, Calif
2	43 - 44	Comdr, TG 7.2, APO 187, c/o PM, San Francisco, Calif
2	45 - 46	Comdr, TG 7.3, APO 187, c/o PM, San Francisco, Calif
4	47 - 50	Comdr, TG 7.5, APO 187, c/o PM, San Francisco, Calif

DEPARTMENT OF DEFENSE AGENCIES

1	51	Chief, AFSWP, Box 2610, Washington 25, D.C.
1	52	CG, AFSWP, Sandia Base, New Mexico

ARMY AGENCIES

1	53	C/S, U.S. Army, Washington 25, D.C.
1	54	CG, USARPAC, APO 958, c/o PM, San Francisco, Calif

NAVY AGENCIES

1	55	CNO, Washington 25, D.C.
1	56	CINCPACFLT, Navy #128, c/o FPO, San Francisco, Calif
1	57	COMHAWSEAFRON, Navy #128, c/o FPO, San Francisco, Calif
1	58	CO, NAVSTA, Kwajalein, Navy #824, c/o FPO, San Francisco, Calif

TASK GROUP 7.4  
OPRS ORDER NO. 8-54

<u>COPIES</u>	<u>COPY NO.</u>	<u>TASK GROUP 7.4, PROVISIONAL, UNITS</u>
10	59 - 68	Comdr, Test Aircraft Unit
10	69 - 78	Comdr, Test Services Unit
6	79 - 84	Comdr, Test Support Unit
<u>HEADQUARTERS, TASK GROUP 7.4, PROVISIONAL, UNITS</u>		
1	85	Commander, TG 7.4
1	86	Deputy Commander
1	87	Chief of Staff
5	88 - 92	Director of Operations
2	93 - 94	Director of Personnel
2	95 - 96	Director of Materiel
1	97	Comptroller
1	98	Personnel Security Officer
1	99	Historian
1	100 - 114	Adjutant, Hq Task Group 7.4 (REAR), Kirtland AFB, NM

ANNEX A

ANNEX A

TO

OPERATIONS ORDER NO. 8-54

TASK GROUP 7.4 CHECK LIST

TASK GROUP 7.4  
OPRS ORDER NO. 8-54  
ANNEX A

A

TASK GROUP 7.4 CHECK LIST

<u>ITEM</u>	<u>D/Y</u>	<u>HOOR</u>	<u>EVENT</u>
1	Y-4	0700	Three (3) WB-29 Weather Reconnaissance missions per day begin.
2	Y-4	0900	Positioning meeting at Hq, Task Group 7.1 to firm positions of all aircraft for YANKEE event.
3	Y-4	1600	Publish Task Group 7.4 Operations Order 8-54.
4	Y-4	1900	CTG 7.4 reports state of readiness of TG 7.4 to CJTF SEVEN.
5	Y-3	0800	Project participants arrive ENIWETOK.
6	Y-3	1700	JTF SEVEN notifies CINCPAC that ENIWETOK and BIKINI airstrips are closed to air traffic. Only scheduled MATS and official observer flights will land at ENIWETOK.
7	Y-2	0700	JTF SEVEN official observers arrive at ENIWETOK.
8	Y-2	0900	AOC confirms requirements for post mission, inter-atoll airlift operations. Notify CIC of all confirmed missions.
9	Y-2	1000	Mission flimsies issued to all aircrews by Test Aircraft Unit.
10	Y-2	1200	Two forecasters from Weather Central board USS ESTES.
11	Y-2	1300	Required radiological instruments issued by Test Aircraft Unit to B-36 and B-29 Radiological Directors.
12	Y-2		CIC checks Time Hack communications.
13	Y-2		Test Aircraft Unit designates mission tower officer.
14	Y-2	1600	Three (3) sample return aircraft (FLY-AWAY 1, 2 and 3) arrive at ENIWETOK.
15	Y-2		Three (3) B-50 IBDA aircraft arrive at ENIWETOK from GUAM. Radio and IFF checked in these acft.
16	Y-1	0700	AOC insures that tower personnel are rebriefed on Y-Day mission.

TASK GROUP 7.4  
OPRS ORDER NO. 8-54  
ANNEX A

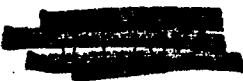

Declassified  
DOD DIR 5200.10

Declassified  
DOD DIR 5200.10

<u>ITEM</u>	<u>DAY</u>	<u>HOUR</u>	<u>EVENT</u>
17	Y-1	0700	Test Support Unit insures that crash removal crews are briefed and prepared for Y-Day assignments.
17A			Test Spt Unit insures that final arrangements are made for messing & transportation during the mission.
18	Y-1	0730	Acft Status Report submitted to CIC by AOC.
19	Y-1		AOC submits full "Midnight Report" by 0800.
20	Y-1	0800	General and specialized briefings begin.
21			CIC reports state of readiness of Task Group 7.4 to JTF SEVEN.
22	Y-1	0900	Amphibious aircraft departs on rawindsonde and homer mission to RONGERIK.
23	Y-1		JTF SEVEN personnel board USS ESTES.
24	Y-1	1000	CIC secures ETD of Commander, Task Group 7.4 from AOC.
25	Y-1	1100	CJTF SEVEN commander's conference.
26	Y-1	1230	"Execute" order from CIC to AOC.
27	Y-1	1230	Commander and Senior Controller of Task Group 7.4 departs ENIWETOK for USS ESTES.
28	Y-1	1245	Last aircraft departs BIKINI and inter-atoll airlift operations are discontinued.
29	Y-1	1300	Marshalling of mission aircraft begins. Final position of DOLL HOUSE determined by Task Group 7.3 and Task Group 7.4.
30	Y-1	1300	Test Support Unit checks crash phone operation.
31	Y-1	1400	VIP aircrew specialized briefing.
32	Y-1	1500	Commander, Task Group 7.4 boards USS ESTES.
33	Y-1	1600	Test Aircraft Unit forwards any changes in operational plan to the AOC for dissemination to the CIC and other control agencies.

TASK GROUP 7.4  
OPRS ORDER NO. 8-54  
ANNEX "

Declassified  
DOD DIR 5200.10

A-2

Declassified  
DOD DIR 5200.10

Declassified  
DOD DIR 5200.10

Declassified  
DOD DIR 5200.10

<u>ITEM</u>	<u>DAY</u>	<u>HOUR</u>	<u>EVENT</u>
34	Y-1		Director of Materiel inspects fire fighting and crash removal equipment.
35	Y-1		Senior Controller makes final changes in General Estes' check lists, if applicable.
36	Y-1		One B-50 HARDTIME aircraft modified to include capability of crater photography.
37	Y-1		USS ESTES leaves lagoon for H-Hour position.
38	Y-1	1630	CIC Controller's briefing by Senior Air Controller. Designate officer to standby on Dr. Ogles' phone.
39	Y-1	1700	Test Aircraft Unit submits Y-Day aircraft clearances to Base Operations.
40			PLANK-SLATER Report to Commander, Task Group 7.4 through AOC to CIC.
41	Y-1	1720	Aircraft marshalling completed.
42	Y-1	1800	AOC communications and equipment checked.
43			Final master report submitted to JOC.
44	Y-1	1830	Deputy Commander, Task Group 7.4 in place at AOC and all commanders immediately available.
45	Y-1	1845	CIC routine maintenance completed. Status reports received from Electronics Officer on: <ul style="list-style-type: none"><li>a. SPS-6</li><li>b. Mark 10 IFF</li><li>c. VHF radio</li><li>d. HF radio</li></ul>
46	Y-1	1845	CIC personnel briefed.
47			CIC duty schedules formed to include: <ul style="list-style-type: none"><li>a. Reporting Time</li><li>b. CIC crew relief set up</li><li>c. Meal schedules arranged</li></ul>
48	Y-1	2210	JTF SEVEN passes directive to Task Group 7.4 concerning flight #1 (WILSON 2) WB-29-cloud tracker.

Declassified  
DOD DIR 5200.10

TASK GROUP 7.4  
OPRS ORDER NO. 8-54  
ANNEX A

Declassified  
DOD DIR 5200.10

Declassified  
DOD DIR 5200.10

Declassified  
DOD DIR 5200.10

<u>ITEM</u>	<u>DAY</u>	<u>HOUR</u>	<u>EVENT</u>
49	Y-1	2300 H-7:10	Deputy Commander and Staff, including weather forecaster meet to finalize "Midnight Report."
50	Y-1	2315 H-6:55	DOLL HOUSE on station, begins listening watch on J-407 and J-408.
51	Y-1	2330 H-6:40	"Midnight Report" forward by AOC to CIC.
52	Y	*0025 H-5:45	AOC fully manned.
53	Y	0100 H-5:10	Time check AOC to tower and Unit Operations.
54	Y	0100 H-5:10	Wake up CIC Enlisted Crew. Receive final CIC Electronic Status Report.
55	Y	0100 H-5:10	SAR alert crew and crash boat personnel in position at ENIWETOK.
56	Y	*0115 H-4:55	First aircraft position #1.
57	Y	*0120 H-4:50	CIC Enlisted crew reports for duty.
58	Y	*0120 H-4:50	Control Destroyer CIC fully manned.
59	Y	0130 H-4:40	CIC posts weather and sea conditions.
60	Y	*0150 H-4:20	CIC Scope Controller #4 reports for duty.
61	Y	*0200 H-4:10	CIC Scope Controller #3 reports for duty.
62	Y	*0210 H-4:00	CIC Scope Controller #7 reports for duty.
63	Y	*0220 H-3:50	CIC Scope Controller #2 reports for duty.
64	Y	0230 H-3:40	CIC posts weather and sea conditions.
65	Y	*0240 H-3:30	CIC Scope Controller #5 reports for duty.
66	Y	*0240 H-3:30	CIC checks time broadcast with flag plot.
67	Y	*0308 H-3:02	Time hack ( <u>Blink</u> light 3 seconds - all aircraft for H-3 hours. CIC checks)

TASK GROUP 7.4  
OPRS ORDER NO. 8-54  
ANNEX A

Declassified  
DOD DIR 5200.10

Declassified  
DOD DIR 5200.10

A-4

\*Items so marked will maintain same H-Hour factor. In the event of H-Hour time change, adjust clock

time

<u>ITEM</u>	<u>DAY</u>	<u>HOUR</u>	<u>EVENT</u>
68	Y	*0310 H-3:00	Time Hack.
69	Y	*0310 H-3:00	CIC checks time broadcast with flag plot.
70	Y	*0310 H-3:00	"Execute" order received by CIC from JOC; forward to AOC.
71	Y	*0315 H-2:55	CIC Scope Controller #6 reports for duty.
72	Y	0330 H-2:40	CIC posts weather and sea conditions.
73	Y	*0405 H-2:05	Last VIKING aircraft departs FRED, CIC reports to JOC.
74	Y	*0408 H-2:02	Time Hack ( <u>Blink</u> light 3 seconds - all aircraft for H-2 hours. CIC checks).
75	Y	*0410 H-2:00	CIC Scope Controller #1 reports for duty.
76	Y	*0410 H-2:00	H-2:00 Time Hack
77	Y	*0420 H-1:50	CIC checks CASSIDY Homer (450. kcs).
78	Y	0430 H-1:40	CIC posts weather and sea conditions.
79	Y	*0438 H-1:32	Time Hack ( <u>Blink</u> light 3 seconds - all air- craft for H-1:30. CIC checks).
80	Y	*0440 H-1:30	H-1:30 Time Hack.
81	Y	*0508 H-1:02	CIC Time Hack ( <u>Blink</u> light 3 seconds - all aircraft for H-1:00 time hack, CIC checks.)
82	Y	*0510 H-1:00	H-1:00 Time Hack.
83	Y	*0520 H-0:50	Actual winds aloft checked with airborne air- craft, CIC checks.
84	Y	*0523 H-0:47	CIC Time Hack ( <u>Solid</u> light 3 seconds - HARDTIME and Effects aircraft for H-45 minutes.)
85	Y	*0525 H-0:45	H-0:45 Time Hack.

Declassified  
DOD DIR 5200.10

\*Items so marked will maintain same H-Hour  
factor. In the event of H-Hour time change,  
adjust clock time.

TASK GROUP 7.4  
OPRS ORDER NO. 8-54  
ANNEX A

Declassified  
DOD DIR 5200.10

<u>ITEM</u>	<u>DAY</u>	<u>HOOR</u>	<u>EVENT</u>
86	Y	*0530 H-0:40	DOLL HOUSE reports estimated position for H-Hour to CIC.
87	Y	0530 H-0:40	CIC posts weather and sea conditions.
88	Y	*0538 H-0:32	CIC Time Hack ( <u>Blink</u> light 3 seconds all aircraft for H-30 minutes.)
89	Y	*0540 H-0:30	H-0:30 Time Hack
90	Y	*0545 H-0:25	Wake up relief CIC Enlisted crews, CIC receives JOC report.
91	Y	*0545 H-0:25	Controller brief pilots on Time Hack.
92	Y	*0545 H-0:25	SAR SA-16, H-19 and crash boat alerted by AOC for first F-84 take-off.
93	Y	*0550 H-0:20	Radio transmissions held to a minimum.
94	Y	*0550 H-0:20	CIC officer stands by in JOC on direct line to Dr. Ogle to pass any message from Dr. Ogle to General Estes.
95	Y	*0553 H-0:17	CIC time hack ( <u>Blink</u> light 3 seconds all aircraft for H-15 minutes.)
96	Y	*0555 H-0:15	H-0:15 Time Hack
97	Y	*0555 H-0:15	Decision is made as to where ELAINE #2 will land.
98	Y	*0558 H-0:12	Time Hack ( <u>Blink</u> light 3 seconds all aircraft for H-10 Minutes.)
99	Y	*0600 H-0:10	H-0:10 Time Hack.
100	Y	*0600 H-0:10	First F-84 sampler flight takes-off.
101	Y	*0605 H-0:05	All CIC controller report positions of aircraft.

\*Items so marked will maintain same H-Hour factor. In the event H-Hour time change, adjust clock time.

TASK GROUP 7.4  
OPRS ORDER NO. 8-54  
ANNEX A

Declassified  
DOD DIR 5200.10

A-6

Declassified  
DOD DIR 5200.10

<u>ITEM</u>	<u>DAY</u>	<u>HOUR</u>	<u>EVENT</u>
102	Y	*0605 H-0:05	Senior Controller makes final positioning report to CTG 7.4.
103	Y	*0605 H-0:05	REFLECTOR directed to return to FRED if relay equipment is inoperative.
104	Y	*0606 H-0:04	JOC notified by CIC all aircraft in position.
105	Y	*0606 H-0:04	CIC Time Hack ( <u>Blink</u> light 6 seconds for all aircraft. All aircraft remain on VHF Channel "B" until H-Hour) for H-3 minutes.
106	Y	*0610 H-0:00	H-Hour
107	Y	*0610 H-0:00	Controllers record H-Hour positions of aircraft.
108	Y	*0615 H-0:05	USS ESTES begins movement to safe position.
109	Y	*0625 H-0:15	JOC notifies CURTISS to come up on 400 kcs.
110	Y	*0625 H-0:15	CIC checks NAN, RONGERIK, CURTISS and CASSIDY homers.
111	Y	*0625 H-0:15	AOC checks towing of sample return aircraft to SW parking ramp.
112	Y	*0625 H-0:15	CIC checks JOC on status of TARE.
113	Y	*0630 H-0:20	JOC instructs TG 7.3 to have one HRS on alert to pick up any crews forced to land on TARE, CIC checks.
114	Y	0630 H-0:20	CIC posts weather and sea conditions.
115	Y	0630 H-0:20	CIC reports CASSIDY position to AOC.
116	Y	*0640 H-0:30	Relieve CIC and Enlisted Crew.
117	Y	*0640 H-0:30	General Estes transmits TARE report to AOC.

\*Items so marked will maintain same H-Hour factor. In the event of H-Hour time change, adjust clock time.

TASK GROUP 7.4  
OPRS ORDER NO. 8-54  
ANNEX A

Declassified  
DOD DIR 5200.10

Declassified  
DOD DIR 5200.10

<u>ITEM</u>	<u>DAY</u>	<u>HOOR</u>	<u>EVENT</u>
118	Y	*0645 H/0:30	Advise SNIFFER pilots of TARE Airfield conditions
119	Y	*0700 H/0:50	WB-29 WILSON #3 cloud tracker departs ENIWETOK.
120	Y	*0700 H/0:50	CIC reports CASSIDY position to AOC.
121	Y	*0710 H/1:00	CIC checks with AOC to insure completeness of sample removal plans for aircraft forced to land at KWAJ/LEIN.
122	Y	*0710 H/1:00	Project Participants' aircraft depart operational area for destination.
123	Y	*0715 H/1:05	WB-29 WILSON #2 cloud tracker departs ENIWETOK.
124	Y	*0725 H/1:15	Initiate B.U. action.
125	Y	0730 H/1:20	CIC reports CASSIDY position to AOC.
126	Y	0730 H/1:20	CIC posts weather and sea conditions.
127	Y	*0740 H/1:30	Personnel in position on ENIWETOK for processing B-50 aircraft for departure after completion of mission. AOC checks.
128	Y	*0740 H/1:30	Sampler pilots advised of TARE airfield conditions.
129	Y	0800 H/1:50	CIC reports CASSIDY position to AOC.
130	Y	*0810 H/2:00	Filter sample plus one monitor transported from FRED to ELMER via L-13 (Time of flight dependent upon time WB-29 lands.)
131	Y	*0825 H/2:15	Gas sample bags and monitor transported from FRED to ELMER via H-19 helicopter.
132	Y	*0825 H/2:15	Filter sample plus one monitor transported from FRED to ELMER by L-13.

\*Items so marked will maintain same H-Hour factor. In the event of H-Hour time change, adjust clock time.

TASK GROUP 7.4  
OPRS ORDER NO. 8-54  
ANNEX A

A-8

Declassified  
DOD DIR 5200.10

Declassified  
DOD DIR 5200.10

Declassified  
DOD DIR 5200.10

<u>ITEM</u>	<u>DAY</u>	<u>HOOR</u>	<u>EVENT</u>
133	Y	0830 H/2:20	CIC posts weather and sea conditions.
134	Y	0830 H/2:20	CIC reports CASSIDY position to AOC.
135	Y	0900 H/2:50	Director of Materiel inspects HARDTIME aircraft for damage.
136	Y	0900 H/2:50	CIC reports CASSIDY position to AOC.
137	Y	*0910 H/3:00	Helicopter dispatched to NAN, GEORGE and TARE to accomplish Rad/Safe survey and early recovery.
138	Y	0930 H/3:20	CIC reports CASSIDY position to AOC.
139	Y	0930 H/3:20	CIC posts weather and sea conditions.
140	Y	1000 H/3:50	CIC reports CASSIDY position to AOC.
141	Y	*1010 H/4:00	Two (2) B-50 HARDTIME aircraft scheduled to depart ENIWETOK For GUAM. Third HARDTIME aircraft will depart for GUAM after crater photo mission is accomplished.
142	Y	1030 H/4:20	CIC posts weather and sea conditions.
143	Y	1030 H/4:20	CIC reports CASSIDY position to AOC.
144	Y	1100 H/4:50	CIC reports CASSIDY position to AOC.
145	Y	*1110 H/5:00	Relieve CIC Enlisted Crew.
146	Y	*1110 H/5:00	CIC checks with JOC Rad/Safe for recommendation concerning crater photography.
147	Y	1130 H/5:20	CIC post weather and sea conditions.
148	Y	1130 H/5:20	CIC reports CASSIDY position to AOC.
149	Y	1200 H/5:50	CIC reports CASSIDY position to AOC.

\*Items so marked will maintain same H-Hour factor. In the event of H-Hour time change, adjust clock time.

TASK GROUP 7.4  
OPRS ORDER NO. 8-54  
ANNEX A

Declassified  
DOD DIR 5200.10

Declassified  
DOD DIR 5200.10

Declassified  
DOD DIR 5200.10

Declassified  
DOD DIR 5200.18

<u>ITEM</u>	<u>DAY</u>	<u>HOUR</u>	<u>EVENT</u>
150	Y	*1210 H/6:00	WB-29 cloud tracker begins 12 hour post-shot rad/safe mission.
151	Y	1230 H/6:20	CIC reports CASSIDY position to AOC.
152	Y	1300 H/6:50	CIC reports CASSIDY position to AOC.
153	Y	*1330 H/7:20	FLY AWAYS 1 and 2 depart FRED for ZI with Samples aboard.
154	Y	1330 H/7:20	CIC reports CASSIDY position to AOC.
155	Y	1400 H/7:50	CIC reports CASSIDY position to AOC.
156	Y	*1415 H/8:05	Bottle gas samples transported from FRED to ELMER via L-13 (or possibly H-19). H-19 will be required if a bag sample is involved.
157	Y	*1425 H/8:15	One monitor plus 100 lbs of liquid samples (2 cu ft) transported from FRED to ELMER via L-13.
158	Y	1430 H/8:20	CIC reports CASSIDY position to AOC.
159	Y	1430 H/8:20	CTG 7.4 and Senior Controller return to ENIWETOK.
160	Y	1500 H/8:50	CIC reports CASSIDY position to AOC.
161	Y	1530 H/9:20	CIC reports CASSIDY position to AOC.
162	Y	1700	ENIWETOK open to normal traffic.
163	Y	*2155 H/15:45	CIC advised of tracks for third WB-29 (WILSON 4) cloud tracking mission. Information passed to AOC through CIC, or from ELMER by telephone.
164	Y/1	0730	Execute maintenance plan.
165		0800 H/25:50	Telemeter shot film records transported by PBM or C-47 from NAN to FRED.

\*Items so marked will maintain same H-Hour factor. In the event of H-Hour time change adjust clock time.

TASK GROUP 7.4  
OPRS ORDER NO. 8-54  
ANNEX A

Declassified  
DOD DIR 5200.10

1-10

Declassified  
DOD DIR 5200.10

Declassified  
DOD DIR 5200.10

Declassified  
DOD DIR 5200.10

<u>ITEM</u>	<u>DAY</u>	<u>HOUR</u>	<u>EVENT</u>
166	Y/1	0800	B-50 departs FRED for crater photo mission.
167		*0810 H/26:00	CIC advised of tracks for fourth WB-29 (WILSON 5) cloud tracking mission. Information passed to AOC through CIC or from ELMER by telephone.
168		1000	Transport gas samples plus courier and baggage from ELMER by H-19. These samples are destined for ZI via FLY AWAY 3.
169		1130	B-50 returns to FRED from crater photo mission.
170		1200	FLY AWAY #3 departs FRED for ZI with samples aboard.
171		1400	B-50 departs FRED for GUAM
172	Y/2	0800	Commander's Operational Briefing.
173		0800	Post mission inspection to determine extent of any aircraft damage begins.
174		0800	Decontamination of aircraft begins in accordance with established priority schedule.
175		1330	Unit Commanders report the operational status of their aircraft to CTG 7.4.

Declassified  
DOD DIR 5200.10

Declassified  
DOD DIR 5200.10

\*Items so marked will maintain same H-Hour factor. In the event of H-Hour time change, adjust clock time.

TASK GROUP 7.4  
OPRS ORDER NO. 8-54  
ANNEX A

Annex B

ANNEX B

TO

OPERATIONS ORDER NO. 8-54

AIRCRAFT PARKING PLAN

(Limited distribution to be issued separately)

TASK GROUP 7.4  
OPRS ORDER NO. 8-54  
ANNEX B

B

Annex "C"

ANNEX C

TO

OPERATIONS ORDER NO. 8-54

AIRCRAFT MISSION EXECUTION CHART

(To be issued separately)

TASK GROUP 7.4  
OPRS ORDER NO. 8-54  
ANNEX "C"

Annex D

ANNEX D

TO

OPERATIONS ORDER NO. 8-54

AIRCRAFT H-HOUR POSITIONS AND FLIGHT PATTERNS

TASK GROUP 7.4  
OPRS ORDER NO. 8-54  
ANNEX D

D

Declassified  
DOD DIR 5200.10

Declassified  
DOD DIR 5200.10

ANNEX D  
TO  
OPERATIONS ORDER NO. 8-54  
AIRCRAFT H-HOUR POSITIONS AND FLIGHT PATTERNS

HEADQUARTERS  
TASK GROUP 7.4, PROVISIONAL  
APO 137, c/o Postmaster  
San Francisco, California  
1 May 1954, 1800M

1. H-Hour positions of all airborne aircraft relative to Ground Zero are designated in Appendix 1, "H-Hour Aircraft Positioning Chart".
2. Detailed H-Hour range, azimuth, attitude, airspeed, altitude and route requirements for all airborne aircraft are designated in Appendix 2, "H-Hour Aircraft Flight Plans".
3. Flight patterns for aircraft airborne at H-Hour in the shot area are designated in the following appendices:
  - a. Appendix 3, "B-36 and B-47 Flight Patterns".
  - b. Appendix 4, "C-54 Flight Patterns".
  - c. Appendix 5, "B-50 IBDA Flight Patterns".
  - d. Appendix 6, "Observer Aircraft Flight Patterns".
4. All other aircraft airborne will execute orbits at H-Hour Stations.

OFFICIAL:

*Paul H. Fackler*  
PAUL H. FACKLER  
Lt Colonel, USAF  
Director of Operations

HOWELL M. ESTES, JR.  
Brigadier General, U. S. A. F.  
Commander

Appendices:

1. H-Hour A/C Positioning Chart
2. H-Hour A/C Flight Plans
3. B-36 and B-47 Effects Aircraft Patterns
4. C-54 Photo Aircraft Patterns
5. B-50 IBDA Aircraft Pattern
6. Observer Aircraft Pattern

TASK GROUP 7.4  
OPRS ORDER NO. 8-54  
ANNEX D

Declassified  
DOD DIR 5200.10

Declassified  
DOD DIR 5200.10

D-1

Declassified  
DOD DIR 5200.10

Declassified  
DOD DIR 5200.10

~~SECRET~~  
APPENDIX 1  
TO  
OPERATIONS ORDER NO. 8-54

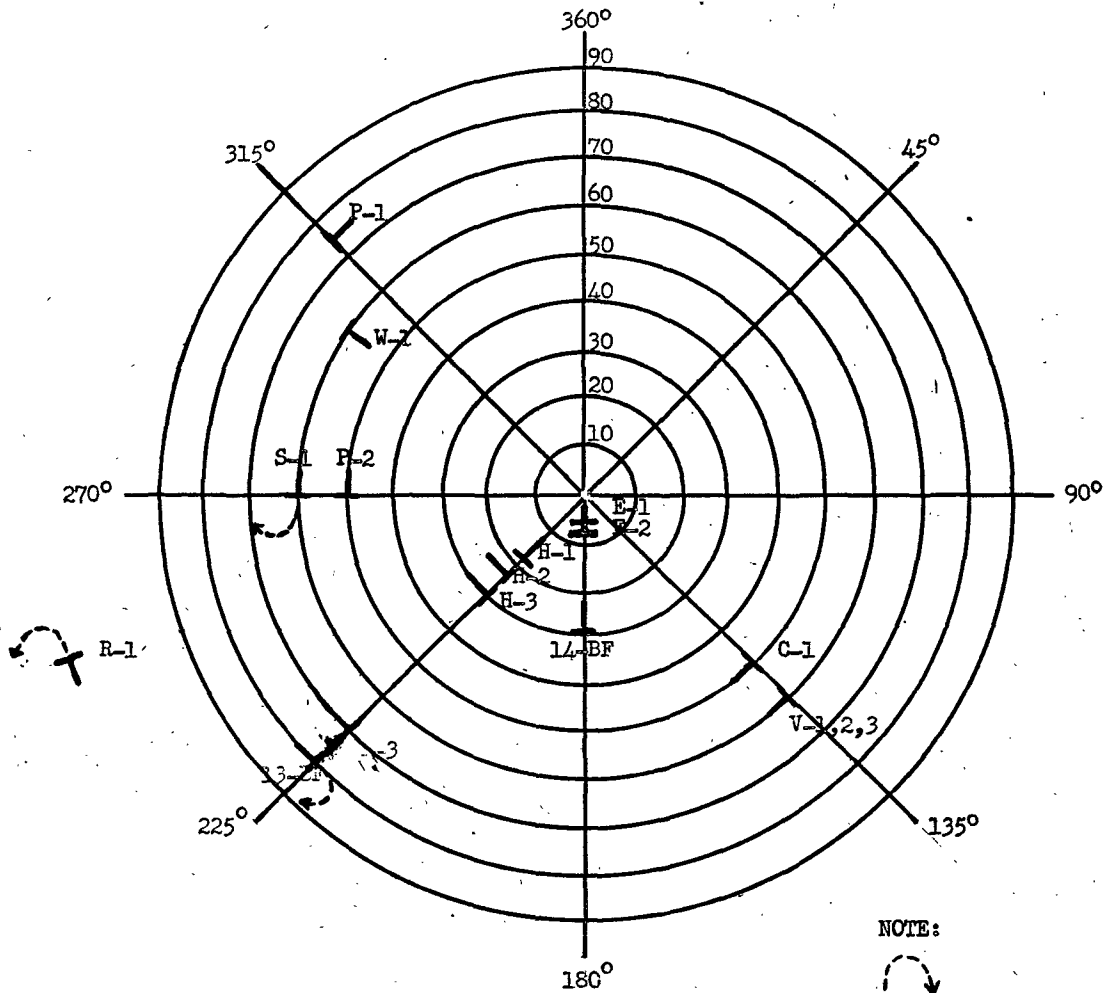

NOTE:



In Orbit

Declassified  
DOD DIR 5200.10

TASK GROUP 7.4  
OPRS ORDER NO. 8-54  
ANNEX "D" APNDX 1

D1-1  
~~SECRET~~

Declassified  
DOD DIR 5200.10

Declassified  
DOD DIR 5200.10

~~TOP SECRET~~  
APPENDIX 2  
TO  
ANNEX "D"  
OPERATIONS ORDER NO. 8-54  
H-HOUR AIRCRAFT FLIGHT PLANS

Declassified  
DOD DIR 5200.10

<u>AIRCRAFT</u>	<u>RANGE</u>	<u>AZIMUTH</u>	<u>ATT</u>	<u>TAS</u>	<u>ALT (Thousand)</u>	<u>ROUTE</u>
ELAINE 1 B-36	39,500	180°	Tail	176K	40	Direct to Orbit
ELAINE 2 B-47	43,000	180°	Tail	442K	35	Direct to Orbit
CASSIDY 1 B-36 Control	50 NM	135°	L Side	250K	40	Direct to Orbit
HARDTIME 1 B-50	15 NM	225°	Tail	280K	32	Direct to Orbit
HARDTIME 2 B-50	23 NM	225°	L Side	280K	31	Direct to Orbit
HARDTIME 3 B-50	30 NM	225°	L Side	280K	30	Direct to Orbit
PEWTER 1 C-54	75 NM	315°	L Side	170K	14	Direct to Orbit
PEWTER 2 C-54	50 NM	270°	L Side	170K	12.5	Direct to Orbit
PEWTER 3 C-54	75 NM	225°	L Side	170K	10.5	Direct to Orbit
STABLE 1 SA-16	60 NM	270°	Orbit	120K	9.5	Direct to Orbit
WILSON 1 WB-29	60-65 NM	305°	Tail	210K	25	TQ H-4 on Eniwetok Wea Survey proceed to Command Ship to Arrive at H-1:50
REFLECTOR 1 C-47	120 NM	255°	Orbit	130K	8.5	Direct to Orbit
13 BABYFOOD P2V-5	80 NM	225°	Orbit		7.5	Direct to Orbit
14 BABYFOOD P4Y-2	50 NM	180°	Tail		8	Direct to Orbit
VIKING 1	60 NM	135°	Side		9	Direct to Orbit
VIKING 2	60 NM	135°	Side		10	Direct to Orbit
VIKING 3	60 NM	135°	Side		11	Direct to Orbit

TASK GROUP 7.4  
OPRS ORDER NO. 8-54  
ANNEX D, APNDX 2

Declassified  
DOD DIR 5200.10

D2-1

Declassified  
DOD DIR 5200.10

Declassified  
DOD DIR 5200.10

Declassified  
DOD DIR 5200.10

APPENDIX 3  
TO  
ANNEX D  
OPERATIONS ORDER NO. 8-54

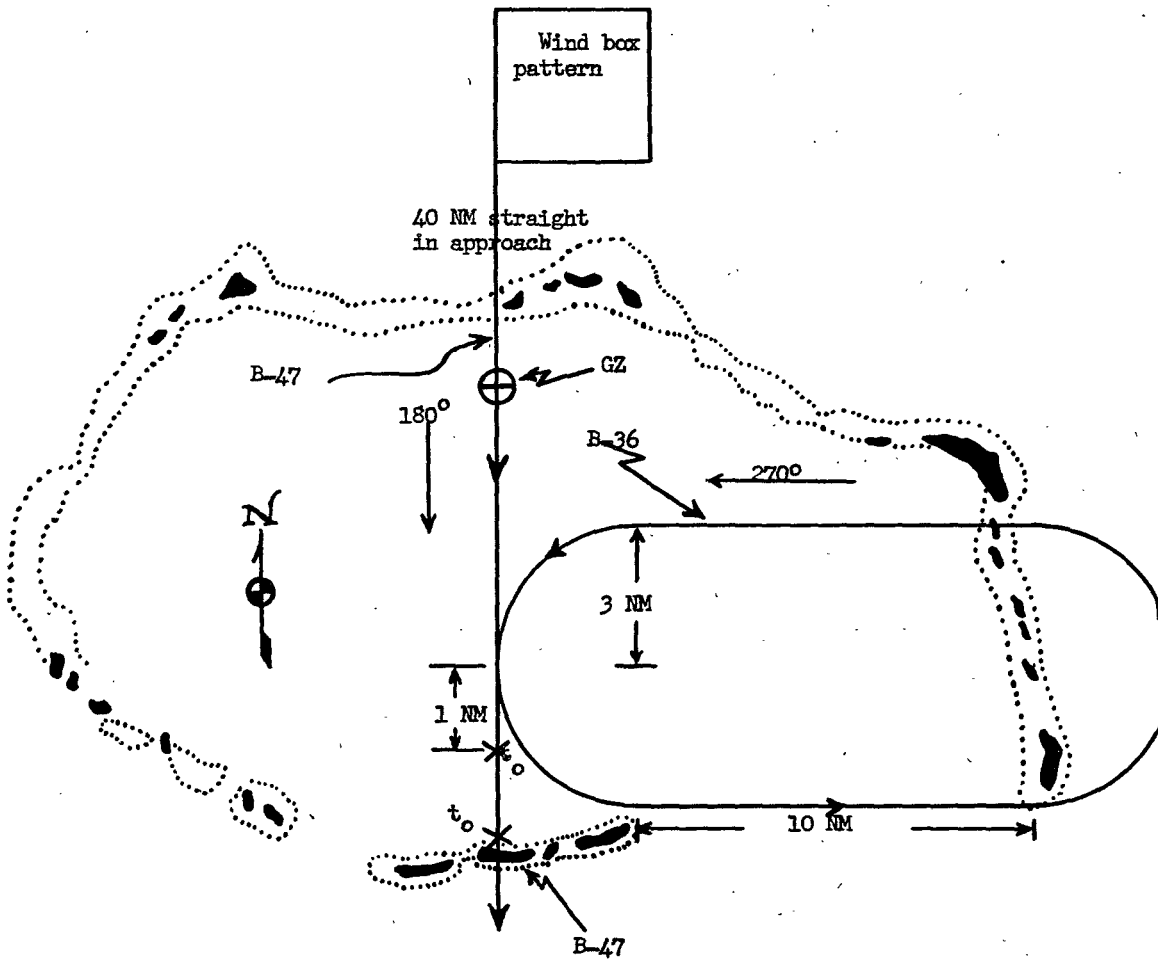

B-47  
Alt - 35,000 ft  
TAS - 442K  
T<sub>0</sub> - 43,000 ft

B-36  
Alt - 40,000 ft  
TAS - 176K  
T<sub>0</sub> - 39,500 ft

Declassified  
DOD DIR 5200.10

D3-1

TASK GROUP 7.4  
OPRS ORDER NO. 8-54  
ANNEX D. APNDX 3

Declassified  
DOD DIR 5200.10

~~SECRET~~

APPENDIX 4  
TO  
OPERATIONS ORDER NO. 8-54

Declassified  
DOD DIR 5200.10

Declassified  
DOD DIR 5200.10

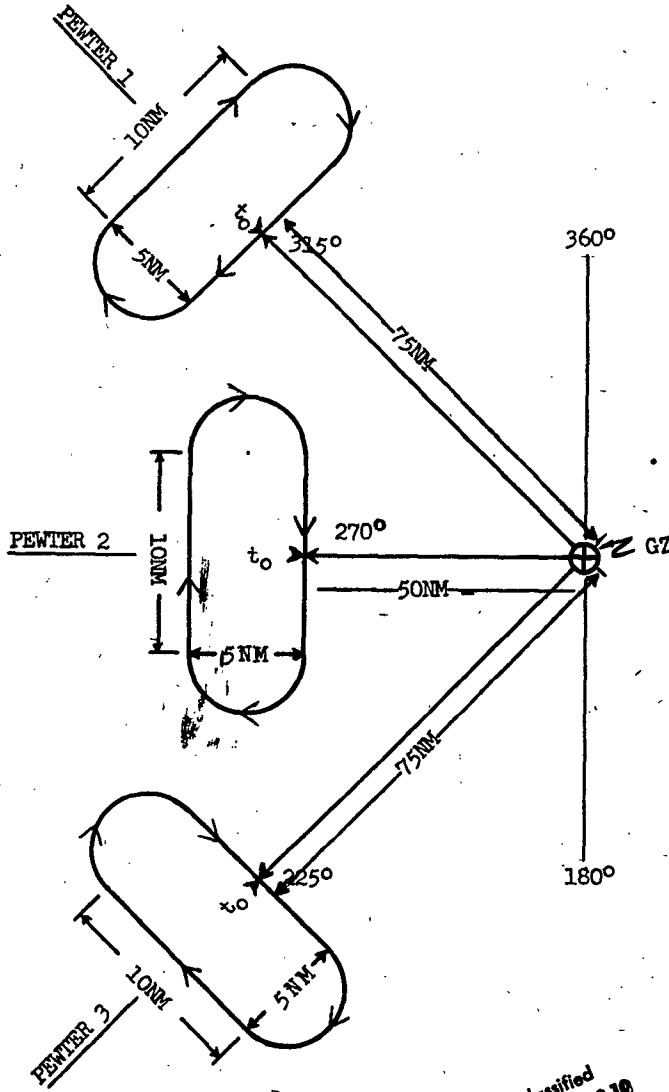

Declassified  
DOD DIR 5200.10

TASK GROUP 7.4  
OPRS ORDER NO. 8-54  
ANNEX L, APNDX 4

D4-1

~~SECRET~~

Declassified  
DOD DIR 5200.10

Declassified  
DOD DIR 5200.10

Declassified  
DOD DIR 5200.10

~~SECRET~~

APPENDIX 5  
TO  
OPERATIONS ORDER NO. 8-54

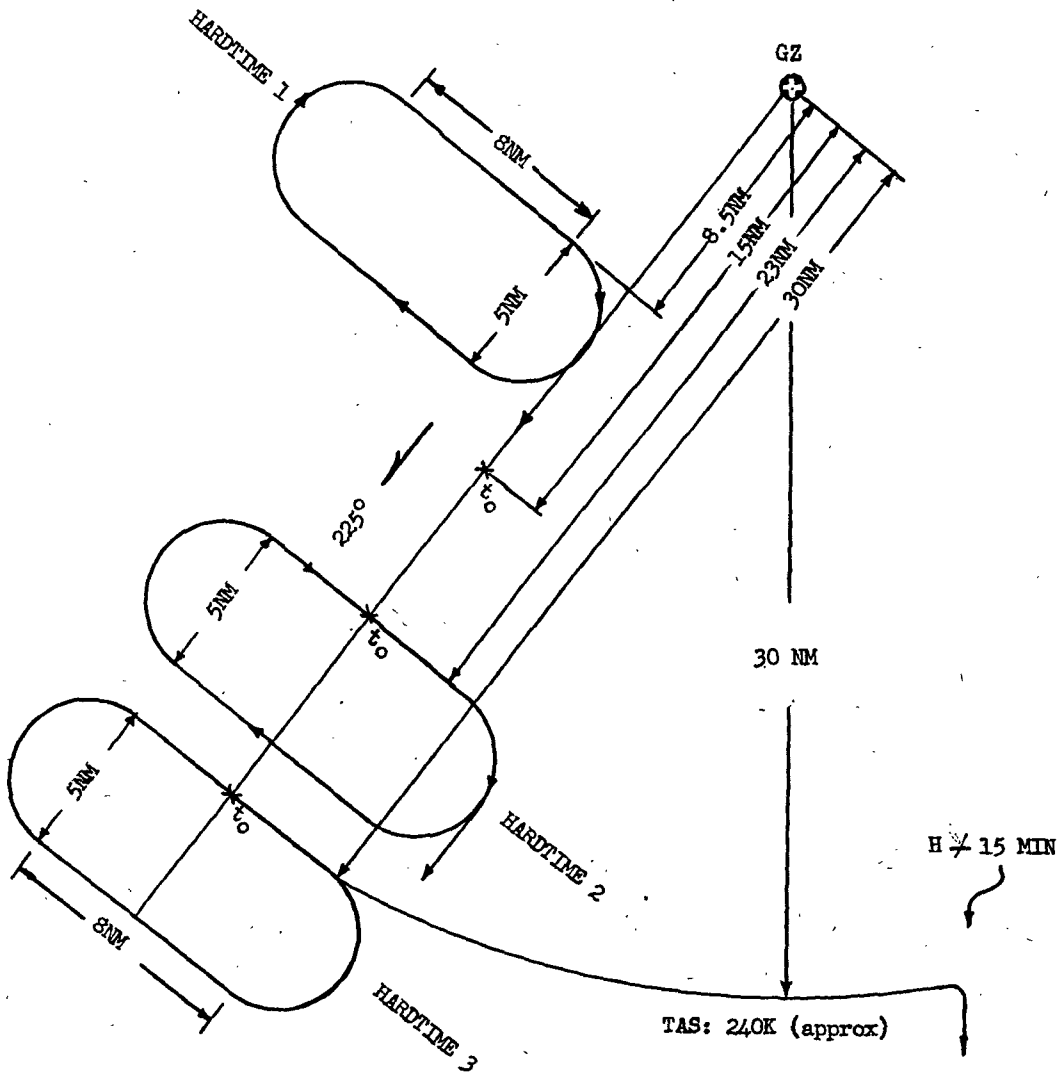

TASK GROUP 7.4  
OPRS ORDER NO. 8-54  
ANNEX D, APNDX 5

D5-1

Declassified  
DOD DIR 5200.10

Declassified  
DOD DIR 5200.10

Declassified  
DOD DIR 5200.10

Declassified  
DOD DIR 5200.10

APPENDIX 6  
TO  
OPERATIONS ORDER NO. 8-54

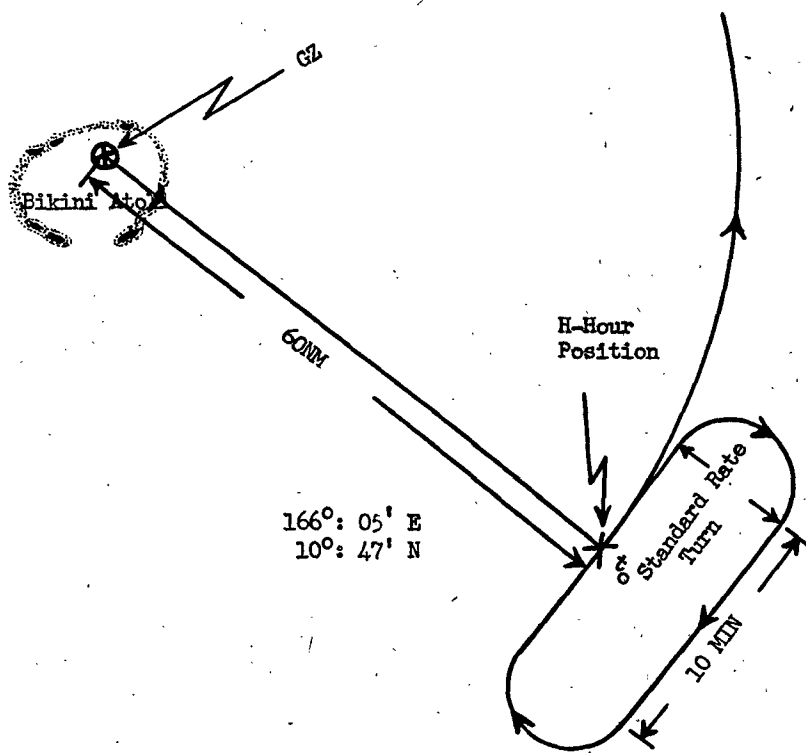

TASK GROUP 7.4  
OPRS ORDER NO. 8-54  
ANNEX D, APNDX 6

Declassified  
DOD DIR 5200.10

Declassified  
DOD DIR 5200.10

HEADQUARTERS  
TASK GROUP 7.4, PROVISIONAL  
APO 137, c/o Postmaster  
San Francisco, California  
1 May 1954, 1800M

GENERAL INFORMATION

ANNEXES "E" THROUGH "Y" INCLUSIVE OF TASK  
GROUP 7.4 OPERATIONS ORDER NO. 2-54 APPLIES  
TO THIS OPERATIONS ORDER.

TASK GROUP 7.4  
OPRS ORDER NO. 8-54